

# FLEXIDOME IP panoramic 5000 MP

www.boschsecurity.com



**BOSCH**  
Invented for life



- ▶ 5MP / 15 fps sensor for fine details with smooth motion
- ▶ Discreet and aesthetic, compact design
- ▶ Simultaneous panoramic overview and detailed object monitoring
- ▶ IK10 rated for better protection
- ▶ Intelligent noise reduction reduces bandwidth and storage requirements by up to 50%

The FLEXIDOME IP panoramic 5000 MP is a discreet, aesthetic, panoramic camera in a compact design. The 5MP sensor operating at 15 fps provides full panoramic surveillance with complete area coverage and fine details. The camera offers full situational awareness and simultaneous E-PTZ views in high resolution.

When mounted centrally on a ceiling, the 360° camera lens gives complete wall-to-wall coverage. When mounted on a wall, the dewarped camera image can provide a 180° image.

### Dewarping

The lens captures a circular image. Our client-side dewarping software transforms this circular image into several different distortion-free rectangular views.

### Versions

Two versions are available, an indoor version and an IK10, IP66-rated outdoor version.

### System overview

#### Advantages of panoramic surveillance

Panoramic surveillance offers full 360° coverage of the designated area. Because our panoramic cameras cover the full area, they provide complete situational awareness and are ideally suited to following movement in one continuous sweep.



### Functions

#### 5MP sensor at 15 fps

The high 5MP sensor resolution together with a frame rate of 15 fps makes this camera an ideal solution for many applications in the field of panoramic image capture. The high resolution provides a clear overview and detailed images.

#### Client-side dewarping

With client-side dewarping, the camera streams a single circular non-dewarped image at 15 fps. Dewarping is performed with our dewarping software that is installed on the PC where multiple view modes are available or you can choose to use a third-party client-side dewarping software solution.

**View modes**

The following view modes can be selected in our client-side dewarping software.

	Full image cut-out and displayed image
Double panoramic view	
E-PTZ view	
North, South, East, West view	
Quad view	
Panoramic view	

The panoramic view modes allows both 180° and 360° viewing.

**DORI coverage**

DORI (Detect, Observe, Recognize, Identify) is a standard system (EN-62676-4) for defining the ability of a camera to distinguish persons or objects within a covered area. The maximum distance at which a camera/lens combination can meet these criteria is shown below:

For high mounting applications, the center image DORI values are:

DORI	Object distance
Detect	22 m (72 ft)
Observe	9.5 m (31 ft)
Recognize	5 m (16 ft)
Identify	2 m (7 ft)

When mounted at a height of 3 m (10 ft) the camera has the following coverage radius for the four levels:

DORI	DORI definition	Coverage radius
Detect	25 px/m (8 px/ft)	19 m (62 ft)
Observe	63 px/m (19 px/ft)	7 m (23 ft)
Recognize	125 px/m (38 px/ft)	4 m (13 ft)
Identify	250 px/m (76 px/ft)	1 m (3 ft)

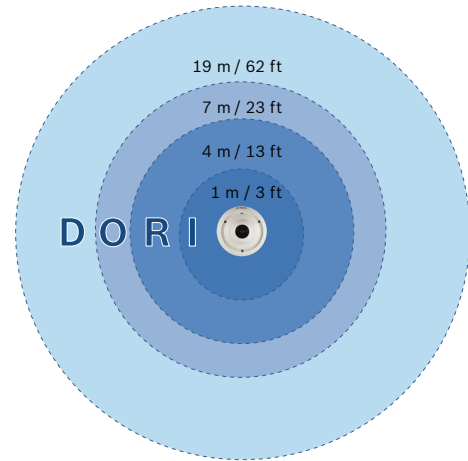

**E-PTZ and regions of interest**

The remote E-PTZ (Electronic Pan, Tilt and Zoom) controls allow you to select specific areas of the full image circle. These Regions of Interest (ROI) can be easily defined, allowing the most interesting part of a scene to be monitored separately. The high resolution ensures that details are not lost even when using the electronic zoom.

The E-PTZ feature of a panoramic camera has some advantages over normal PTZ cameras. There is no camera movement so the camera does not draw attention to itself or appear intrusive. Situational awareness is still retained even when zooming in on a particular object of interest. The smooth E-PTZ function helps navigation, and presets are available as they are with regular PTZ cameras.

**Full image recording**

The camera provides the full resolution circular image for recording even if you are viewing only a portion of the scene. This means that you can always perform retrospective dewarping and analyses on the complete area covered and then zoom in on the region or object of interest.

**Content Based Imaging Technology**

Content Based Imaging Technology (CBIT) is used to radically improve image quality in all lighting conditions and to identify areas for enhanced processing. The camera examines the scene using intelligent video analytics and provides feedback to re-tune the image processing. This provides better detail in the areas that matter and better all-round performance.

### Intelligent Dynamic Noise Reduction

Quiet scenes with little or no movement require a lower bitrate. By intelligently distinguishing between noise and relevant information, Intelligent Dynamic Noise Reduction reduces bitrate by up to 50%. Because noise is reduced at the source during image capture, the lower bitrate does not compromise on video quality.

### Area-based encoding

Area-based encoding is another feature which reduces bandwidth. Compression parameters for up to eight user-definable regions can be set. This allows uninteresting regions to be highly compressed, leaving more bandwidth for important parts of the scene.

### Bitrate optimized profile

The average typical optimized bandwidth in kbits/s for various image rates is shown in the table:

fps	1792 x 1792	1536 x 1536	1024 x 1024	800 x 800	480 x 480
15	2400	2400	700	500	150
7.5	2400	2400	600	300	80
5	2400	2200	400	200	60

### MOTION+

The MOTION+ video motion analysis system that is built into all camera versions is the perfect solution for applications where basic video content analysis features are required. MOTION+ shows motion metadata in an overlay display. By using MOTION+ data as input, smarter imaging algorithms bring improved image quality and more efficient bitrates. It also enables extended tamper detection capabilities.

### Multiple streams

The innovative multi-streaming feature delivers various H.264 streams together with an M-JPEG stream. These streams facilitate bandwidth-efficient viewing and recording, plus easy integration with third-party video management systems.

### Built-in microphone and audio alarm

The indoor version of the camera has a built-in microphone to allow operators to listen in on the monitored area. Audio detection can be used to generate an alarm if needed.

If required by local laws, the microphone can be permanently blocked via a secure license key.

### Easy installation

Power for the camera can be supplied via a Power-over-Ethernet compliant network cable connection. With this configuration, only a single cable connection is required to view, power, and control the camera. Using PoE makes installation easier and more cost-effective, as cameras do not require a local power source. The camera can also be supplied with power from +12 VDC power supplies.

For trouble-free network cabling, the camera supports Auto-MDIX which allows the use of straight or cross-over cables.

The camera is pre-assembled with an indoor surface mount bracket which allows you to mount the camera directly onto a ceiling, wall or single-gang box. The rear connectors are orientated for easy accessibility. A complete set of mounting accessories, such as a wall or pipe mount, are available.

No focus or pan/tilt adjustments are required as the camera, with its 360° lens, provides complete coverage of a small room. The high quality lens is factory focused and so installation is simplified and sharpness is assured.

### Suitable for diverse environments

The indoor version is designed to resemble a smoke-detector. This compact design offers discreet and unobtrusive placement in any indoor environment. The outdoor version with cast-aluminum housing and transparent bubble is designed to withstand the equivalent of 20 joule of impact force (IK10), which is equivalent to a 5 kg (12 lbs) steel ball dropped from 40cm.

Together with the outdoor surface mount box provided in the package, the outdoor version is protected against water and dust ingress according to IP66. This makes it ideal for outdoor use in demanding environments.

### Simple set-up

The camera has a very intuitive user interface that allows fast and easy configuration. Configurable scene modes are provided with the best settings for a variety of applications.

### Storage management

Recording management can be controlled by the Bosch Video Recording Manager (VRM) or the camera can use iSCSI targets directly without any recording software.

### Edge recording

Insert a memory card into the card slot to store up to 2 TB of local alarm recording. Pre-alarm recording in RAM reduces recording bandwidth on the network, and extends the effective life of the memory card.

### Cloud-based services

The camera supports time-based or alarm-based JPEG posting to four different accounts. These accounts can address FTP servers or cloud-based storage facilities (for example, Dropbox). Video clips or JPEG images can also be exported to these accounts.

Alarms can be set up to trigger an e-mail or SMS notification so you are always aware of abnormal events.

### Access Security

Password protection with three levels and 802.1x authentication is supported. To secure Web browser access, use HTTPS with a SSL certificate stored in the camera.

### Complete viewing software

There are many ways to access the camera's features: using a web browser, with the Bosch Video Management System, with the free-of-charge Bosch Video Client or Video Security Client, with the video security mobile app, or via third-party software. The Video Security Client has extensive dewarping capabilities and can be used for client-side dewarping as well as for viewing the available modes.

### System integration

The camera conforms to the ONVIF Profile S specification. Compliance with this standard guarantees interoperability between network video products regardless of manufacturer. Third-party integrators can easily access the internal feature set of the camera for integration into large projects. Visit the Bosch Integration Partner Program (IPP) website ([ipp.boschsecurity.com](http://ipp.boschsecurity.com)) for more information. Because the camera supplies a full circle image stream, it can easily integrate with third-party client-side dewarping software solutions.

### Certifications and approvals

Standards	
Conformity	2004/108/EC (EMC) ; 2006/95/EC (LVD) ; 2011/65/EU
Emission	EN 55022: 2010, +AC (2011); CFR 47 FCC part 15:2012-10-1, Class B; AS/NZS CISPR 22:2009 + A1 (2010)
Immunity	EN 50121-4:2006, +AC:2008; EN 50130-4:2011*
Safety	EN 60950-1:2006, +A11:2009, +A1:2010, +A12:2011, AC:2011; UL 60950-1, 2nd edition:2011; CAN/CSA-C 22.2 No. 60950-1-07, 2nd edition
Environmental tests	EN 50130-5:2011, Class II (Indoor in general, fixed equipment), Alarm systems - Part 5: Environmental test methods
Environmental	EN 60950-22 outdoor UL; EN 55024; VCCI J 55022 V2/V3; ICES-003 Class B; EN 50132-5-2; IEC 62676-2-3; EN 50581 (2012)
Marks	CE, cULus, WEEE, RCM and China RoHS

\* All systems where this camera is used must comply with this standard as well.

### Outdoor version (with surface mount box)

Ingress protection	IP66
Impact protection	IK10
Region	Certification
Europe	CE
USA	UL

### Installation/configuration notes

#### Dimensions – indoor version

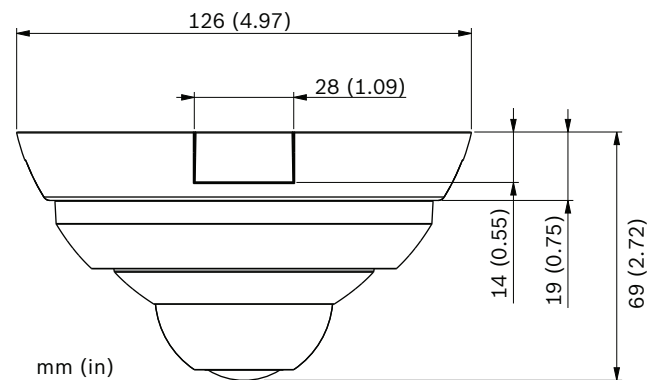
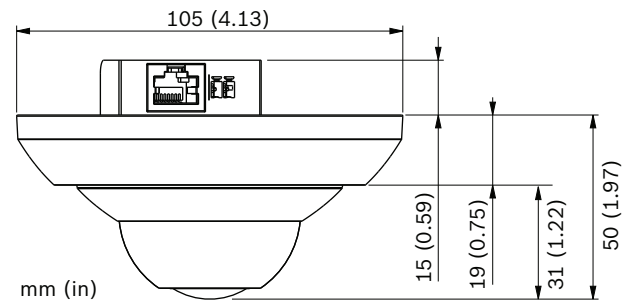

#### Dimensions – outdoor version

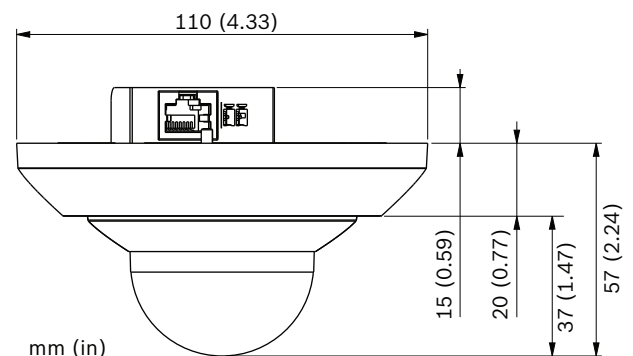

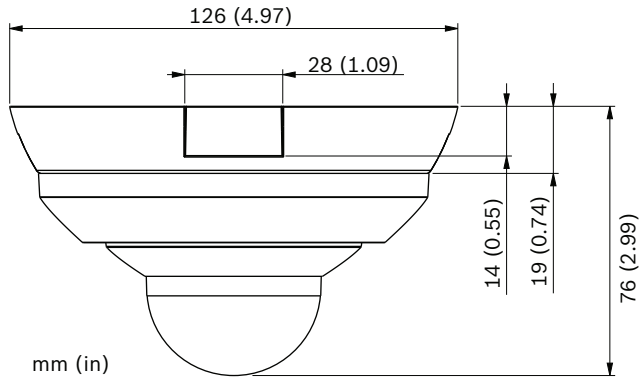

Dimensions - mounting plate

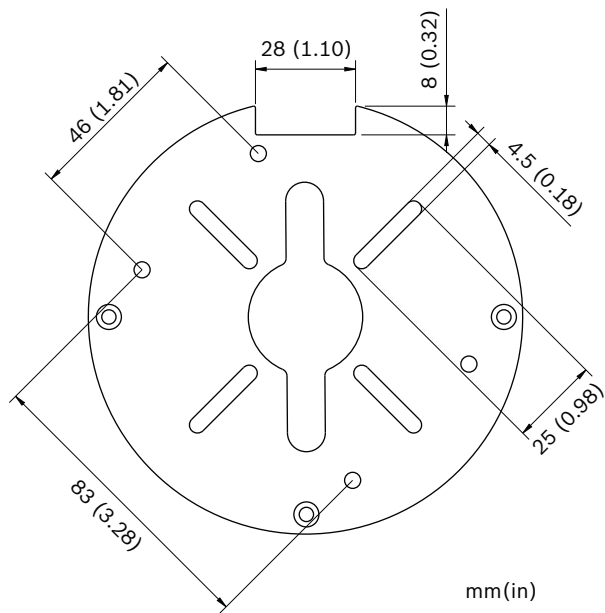

Dimensions - surface mount box

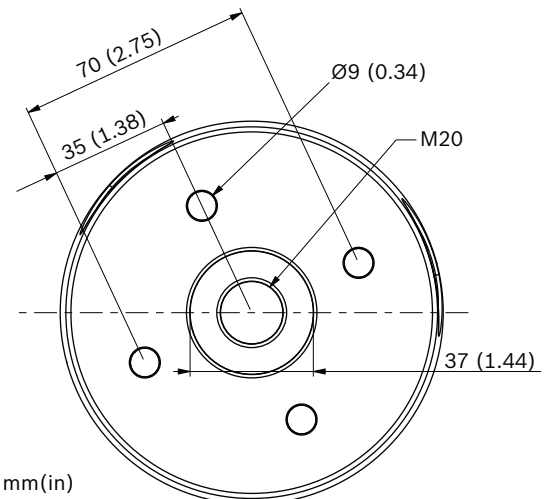
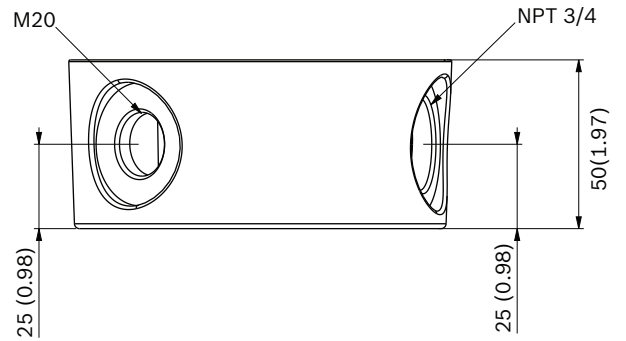

Optional pendant wall mount

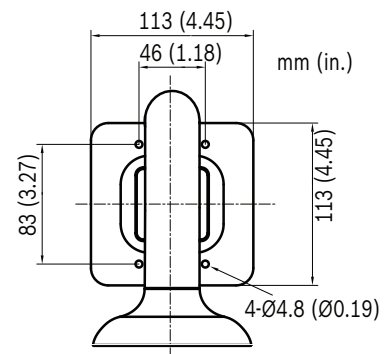

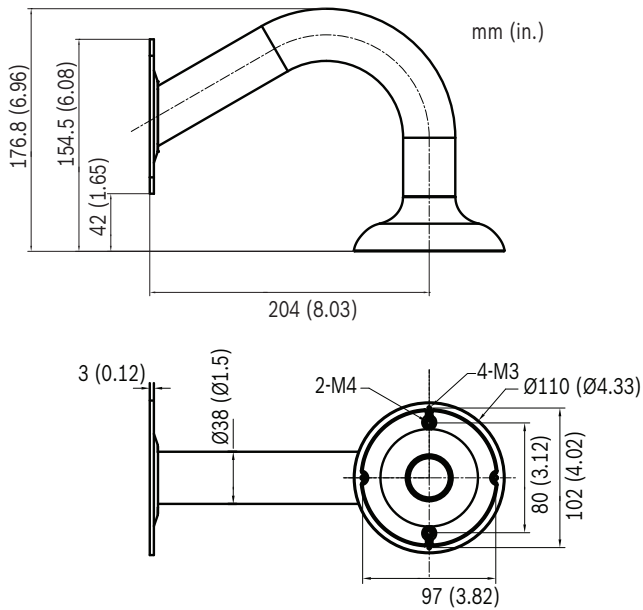

**Optional pendant pipe mount**

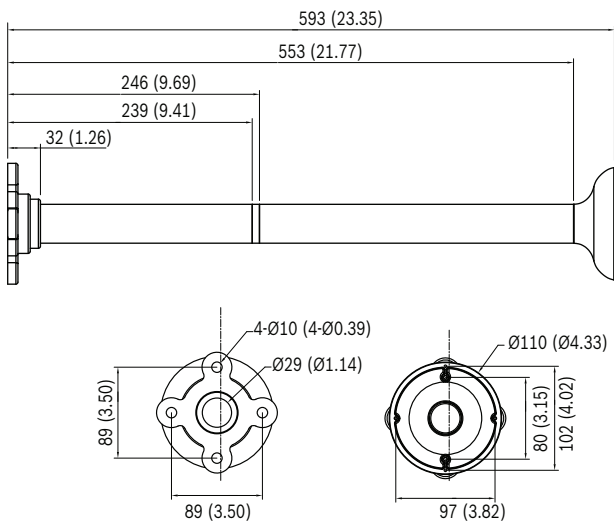

mm (in.)

**Parts included**

The packaging contains:

- FLEXIDOME IP panoramic 5000 MP camera
- Quick install instructions
- Safety instructions
- Mounting template
- Camera screw kit
- Mounting adapter plate
- Indoor surface mount box
- Indoor surface mount box screw kit

**Outdoor version**

- Outdoor surface mount box
- Outdoor surface mount box screw kit
- Desiccant

**Technical specifications**

**Power**

Power Supply	12 VDC Power-over-Ethernet 48 VDC nominal
Current Consumption	300 mA (12 VDC) 75 mA (PoE 48 VDC)
Power Consumption	3.6 W
PoE	IEEE 802.3af (802.3at Type 1) Power level: Class 1

**Sensor**

Type	1/3-inch CMOS
Total sensor pixels	5MP
Used pixels (optical circle)	1792 x 1792 (3.2MP)

**Video performance - Sensitivity**

(3200K, reflectivity 89%, F2.0, 30IRE)

Color	0.36 lx
Mono	0.12 lx

**Video performance - Dynamic range**

Dynamic range	81 dB Wide Dynamic Range (WDR)
---------------	--------------------------------

**Video streaming**

Video compression	H.264 (MP); M- JPEG
Streaming	Multiple configurable streams in H.264 and M- JPEG, configurable frame rate and bandwidth.
Overall IP Delay	Min. 240 ms, Max. 680 ms
GOP structure	IP, IBP, IBBP
Encoding interval	1 to 15 fps

**Video resolution (H x V)**

3.2 MP	1792 x 1792 Full image circle
2.4 MP	1536 x 1536
1 MP	1024 x 1024
0.64 MP	800 x 800
0.23 MP	480 x 480
0.06 MP	240 x 240

Video functions	
Adjustable picture settings	Contrast, Saturation, Brightness
White Balance	Four automatic modes, manual mode and measure
Shutter	Automatic Electronic Shutter (AES) Fixed (1/15 to 1/15000) selectable Default shutter
Sharpness	Sharpness enhancement level selectable
Backlight compensation	On/off
Contrast enhancement	On/off
Noise reduction	Intelligent Dynamic Noise Reduction with separate temporal and spatial adjustments
Intelligent defog	Intelligent Defog automatically adjusts parameters for best picture in foggy or misty scenes (switchable)
Privacy Masking	Eight independent areas, fully programmable
Video Analysis	MOTION+
Other functions	Pixel counter, Video watermarking, Display stamping, Scene modes

Optical	
Lens	360° Fisheye 1.19 mm fixed-focus lens F2.0
Lens mount	Board mounted
Iris control	Fixed iris
Field of view	180° (H) x 180° (V)

Audio streaming	
Standard	G.711, 8 kHz sampling rate L16, 16 kHz sampling rate AAC-LC, 48 kbps at 16 kHz sampling rate AAC-LC, 80 kbps at 16 kHz sampling rate
Signal-to-Noise Ratio	>50 dB
Audio Streaming	Full-duplex / half duplex

Audio (indoor model only)	
Audio input	Integrated microphone (can be permanently disabled)

Local storage	
Internal RAM	10 s pre-alarm recording
Memory card slot	Supports up to 32 GB microSDHC / 2 TB microSDXC card. (An SD card of Class 6 or higher is recommended for HD recording)
Recording	Continuous recording, ring recording, alarm/ events/schedule recording

Software	
Unit discovery	IP Helper
Unit configuration	Via web browser or Configuration Manager
Firmware update	Remotely programmable
Software viewing	Web browser; Video Security Client; Video Security App; Bosch Video Management System; Bosch Video Client; or third party software
Latest firmware and software	<a href="http://downloadstore.boschsecurity.com/">http://downloadstore.boschsecurity.com/</a>

Network	
Protocols	IPv4, IPv6, UDP, TCP, HTTP, HTTPS, RTP/ RTCP, IGMP V2/V3, ICMP, ICMPv6, RTSP, FTP, Telnet, ARP, DHCP, APIPA (Auto-IP, link local address), NTP (SNTP), SNMP (V1, MIB-II), 802.1x, DNS, DNSv6, DDNS (DynDNS.org, selfHOST.de, no-ip.com), SMTP, iSCSI, UPnP (SSDP), DiffServ (QoS), LLDP, SOAP, Dropbox, CHAP, digest authentication
Encryption	TLS 1.0, SSL, DES, 3DES
Ethernet	10/100 Base-T, auto-sensing, half/full duplex
Connectivity	Auto-MDIX
Interoperability	ONVIF Profile S; GB/T 28181

Mechanical (indoor version)	
Dimensions (H x Ø)	50 x 105 mm (1.96 x 4.13 in)
Dimensions (H x Ø) with SMB	69 x 126 mm (2.72 x 4.94 in)
Weight (camera only)	310 g (10.9 oz) approx.
Weight (with SMB)	380 g (13.4 oz) approx.
Color	RAL 9003
Material	Plastic
Mounting options	Wall / Floor / Ceiling / Custom (full 0 to 360° rotation)



**Mechanical (outdoor version)**

Dimensions (H x Ø)	57 x 110 mm (2.24 x 4.33 in)
Dimensions (H x Ø) with indoor SMB	76 x 114 mm (2.99 x 4.47 in)
Dimensions (H x Ø) with outdoor SMB	107 x 114 mm (4.21 x 4.47 in)
Weight (camera only)	360 g (12.7 oz) approx.
Weight (with indoor SMB)	430 g (15.2 oz) approx.
Weight (with outdoor SMB)	830 g (29.3 oz) approx.
Color	RAL 9003
Material	Metal
Mounting options	Wall / Floor / Ceiling / Custom (full 0 to 360° rotation)

**Environmental (indoor version)**

Operating Temperature	-20°C to +50°C (-4°F to 122°F)
Storage Temperature	-30°C to +70°C (-22°F to 158°F)
Operating Humidity	0% to 95% (non-condensing)
Vandal resistance	IK04

**Environmental (outdoor version)**

Operating Temperature	-30°C to +50°C (-22°F to 122°F) for continuous operation; -34 °C to +74 °C (-30 °F to +165 °F) according to NEMA TS 2-2003 (R2008), para 2.1.5.1 using fig. 2.1 test profile
Storage Temperature	-40°C to +70°C (-40°F to 158°F)
Operating Humidity	0% to 95% (non-condensing)
Weatherproofing	IP66
Vandal resistance	IK10

**Ordering information****FLEXIDOME IP panoramic 5000 MP**

Compact indoor IP panoramic camera for all-round MP surveillance. 5MP sensor; PoE/12 VDC; IDNR; H.264 multiple streams; cloud services; client-side dewarping, 360° lens; indoor surface mount box included.

Order number **NUC-52051-F0**

**FLEXIDOME IP panoramic 5000 MP**

Compact outdoor IP panoramic camera for all-round MP surveillance. 5MP sensor; PoE/12 VDC; IDNR; H.264 multiple streams; cloud services; client-side dewarping, 360° lens; IK10; IP66 outdoor surface mount box included.

Order number **NUC-52051-F0E**

**Accessories****NDA-WMT-MICDOME Microdome Pendant Wall Mount**

Wall mount bracket for Microdome cameras

Order number **NDA-WMT-MICDOME**

**NDA-PMT-MICDOME Pendant Pipe Mount Bracket**

Pendant pipe mount bracket for Microdome cameras

Order number **NDA-PMT-MICDOME**

**LTC 9213/01 Pole Mount Adapter**

Flexible pole mount adapter for camera mounts (use together with the appropriate wall mount bracket). Max. 9 kg (20 lb); 3 to 15 inch diameter pole; stainless steel straps

Order number **LTC 9213/01**

**VDA-CMT-PTZDOME Corner Mount Adapter**

Corner mount adapter for use with the appropriate wall mount for indoor or outdoor pole (mast) applications

Order number **VDA-CMT-PTZDOME**



**Represented by:**

**Americas:**

Bosch Security Systems, Inc.  
130 Perinton Parkway  
Fairport, New York, 14450, USA  
Phone: +1 800 289 0096  
Fax: +1 585 223 9180  
security.sales@us.bosch.com  
www.boschsecurity.us

**Europe, Middle East, Africa:**

Bosch Security Systems B.V.  
P.O. Box 80002  
5617 BA Eindhoven, The Netherlands  
Phone: + 31 40 2577 284  
Fax: +31 40 2577 330  
emea.securitysystems@bosch.com  
www.boschsecurity.com

**Asia-Pacific:**

Robert Bosch (SEA) Pte Ltd, Security  
Systems  
11 Bishan Street 21  
Singapore 573943  
Phone: +65 6571 2808  
Fax: +65 6571 2699  
apr.securitysystems@bosch.com  
www.boschsecurity.asia

**China:**

Bosch (Shanghai) Security Systems Ltd.  
203 Building, No. 333 Fuquan Road  
North IBP  
Changning District, Shanghai  
200335 China  
Phone +86 21 22181111  
Fax: +86 21 22182398  
www.boschsecurity.com.cn

**America Latina:**

Robert Bosch Ltda Security Systems Division  
Via Anhanguera, Km 98  
CEP 13065-900  
Campinas, Sao Paulo, Brazil  
Phone: +55 19 2103 2860  
Fax: +55 19 2103 2862  
latam.boschsecurity@bosch.com  
www.boschsecurity.com