

# USB EDC Vertical 2ME

---

---

**Customer:** \_\_\_\_\_

**Customer** \_\_\_\_\_

**Part Number:** \_\_\_\_\_

**Innodisk** \_\_\_\_\_

**Part Number:** \_\_\_\_\_

**Innodisk** \_\_\_\_\_

**Model Name:** \_\_\_\_\_

**Date:** \_\_\_\_\_

|                              |                              |
|------------------------------|------------------------------|
| <b>Innodisk<br/>Approver</b> | <b>Customer<br/>Approver</b> |
|                              |                              |

**The Total Solution For  
Industrial Flash Storage**

## Table of contents

|   |           |
|---|-----------|
| <b>TABLE OF CONTENTS</b> .....                  | <b>2</b>  |
| <b>REVISION HISTORY</b> .....                   | <b>3</b>  |
| <b>LIST OF FIGURES</b> .....                    | <b>4</b>  |
| <b>1. PRODUCT OVERVIEW</b> .....                | <b>6</b>  |
| <b>1.1 INTRODUCTION OF USB EDC</b> .....        | <b>6</b>  |
| <b>1.2 PRODUCT VIEW</b> .....                   | <b>6</b>  |
| <b>1.3 PRODUCT MODELS</b> .....                 | <b>6</b>  |
| <b>1.4 CAPACITY</b> .....                       | <b>6</b>  |
| <b>1.5 VID/PID</b> .....                        | <b>6</b>  |
| <b>2. THEORY OF OPERATION</b> .....             | <b>7</b>  |
| <b>2.1 OVERVIEW</b> .....                       | <b>7</b>  |
| <b>2.2 ERROR DETECTION AND CORRECTION</b> ..... | <b>7</b>  |
| <b>2.3 WEAR-LEVELING</b> .....                  | <b>7</b>  |
| <b>2.4 BAD BLOCKS MANAGEMENT</b> .....          | <b>8</b>  |
| <b>3. SPECIFICATIONS</b> .....                  | <b>9</b>  |
| <b>3.1 CE AND FCC COMPATIBILITY</b> .....       | <b>9</b>  |
| <b>3.2 RoHS COMPLIANCE</b> .....                | <b>9</b>  |
| <b>3.3 ENVIRONMENTAL SPECIFICATIONS</b> .....   | <b>9</b>  |
| <b>3.4 PIN ASSIGNMENT</b> .....                 | <b>10</b> |
| <b>3.5 MECHANICAL DIMENSIONS</b> .....          | <b>11</b> |
| <b>3.6 WEIGHT</b> .....                         | <b>11</b> |
| <b>3.7 PERFORMANCE</b> .....                    | <b>11</b> |
| <b>3.9 NAND FLASH MEMORY</b> .....              | <b>11</b> |
| <b>4. ELECTRICAL SPECIFICATIONS</b> .....       | <b>12</b> |
| <b>4.1 ABSOLUTE MAXIMUM RATINGS</b> .....       | <b>12</b> |
| <b>4.2 OPERATING CONDITIONS</b> .....           | <b>12</b> |
| <b>4.3 POWER CONSUMPTION</b> .....              | <b>12</b> |
| <b>4.4 DEVICE PARAMETERS</b> .....              | <b>13</b> |
| <b>5. PART NUMBER RULE</b> .....                | <b>14</b> |

## REVISION HISTORY

| Revision | Description                                | Date      |
|----------|--|-----------|
| 1.0      | First Release                              | Sep, 2013 |
| 1.1      | Remove Flash endurance SPEC and Add A19 PN | Feb, 2015 |

## List of Figures

|   |           |
|---|-----------|
| <b>FIGURE 1: USB EDC VERTICAL 2ME .....</b>                       | <b>6</b>  |
| <b>FIGURE 2: USB EDC VERTICAL 2ME BLOCK DIAGRAM .....</b>         | <b>7</b>  |
| <b>FIGURE 3: USB EDC VERTICAL 2ME MECHANICAL DIMENSIONS .....</b> | <b>11</b> |

## List of Tables

|  |           |
|--|-----------|
| <b>TABLE 1: SHOCK/VIBRATION TESTING FOR USB EDC VERTICAL 2ME</b> ..... | <b>9</b>  |
| <b>TABLE 2: USB EDC VERTICAL 2ME MTBF</b> .....                        | <b>10</b> |
| <b>TABLE 3: USB EDC VERTICAL 2ME TBW</b> .....                         | <b>10</b> |
| <b>TABLE 4: USB EDC VERTICAL 2ME PIN ASSIGNMENT</b> .....              | <b>10</b> |
| <b>TABLE 5: USB EDC ABSOLUTE MAXIMUM RATINGS</b> .....                 | <b>12</b> |
| <b>TABLE 6: USB EDC OPERATING CONDITIONS</b> .....                     | <b>12</b> |
| <b>TABLE 7: POWER CONSUMPTION</b> .....                                | <b>12</b> |
| <b>TABLE 8: DEVICE PARAMETERS</b> .....                                | <b>13</b> |

# 1. Product Overview

## 1.1 Introduction of USB EDC

The Innodisk USB EDC (Embedded Disk Card) products provide high capacity USB flash memory storage that electrically complies with High-speed USB 2.0 interface & backward compatible with USB 1.1. The device features attractive small form factor and the connectivity over USB2.0 and the NAND flash architecture provide a faster data transmission.

## 1.2 Product View



Figure 1: USB EDC Vertical 2ME

## 1.3 Product Models

USB EDC Vertical 2ME is available in follow capacities.

- USB EDC Vertical 2ME 4GB
- USB EDC Vertical 2ME 8GB
- USB EDC Vertical 2ME 16GB
- USB EDC Vertical 2ME 32GB

## 1.4 Capacity

USB EDC Vertical 2ME provides unformatted from 4GB up to 32GB capacities within MLC Flash IC.

## 1.5 VID/PID

Customize VID/PID(specify 4bits for each ID, Hexadecimal(0~F))

For Option, Default is 196D/0201.

## 2. Theory of operation

### 2.1 Overview

Figure 2 shows the operation of USB EDC Vertical 2ME from the system level, including the major hardware blocks.

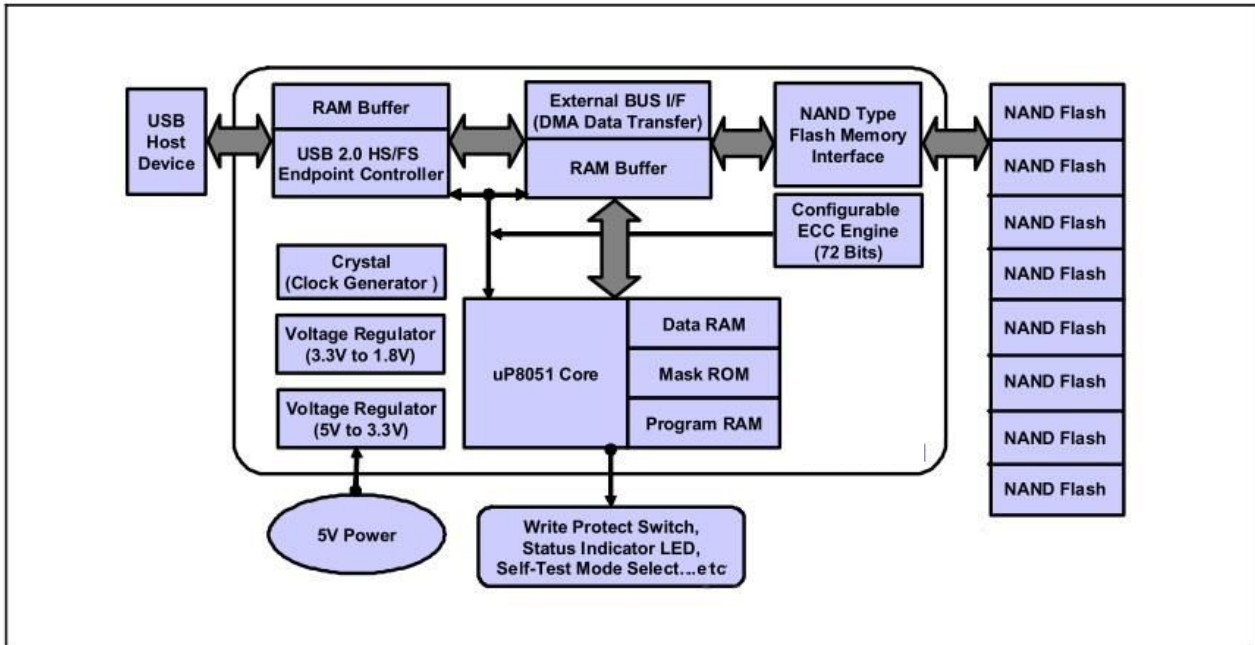

Figure 2: USB EDC Vertical 2ME Block Diagram

USB EDC Vertical 2ME integrates a USB2.0 controller and NAND flash memories. Communication with the host occurs through the host interface. Communication with the flash device(s) occurs through the flash interface.

### 2.2 Error Detection and Correction

Highly sophisticated Error Correction Code algorithms are implemented. The ECC unit consists of the Parity Unit (parity-byte generation) and the Syndrome Unit (syndrome-byte computation). This unit implements an algorithm that can correct 72 bits per 1024 bytes in an ECC block. Code-byte generation during write operations, as well as error detection during read operation, is implemented on the fly without any speed penalties.

### 2.3 Wear-Leveling

Flash memory can be erased within a limited number of times. This number is called the *erase cycle limit* or *write endurance limit* and is defined by the flash array vendor. The erase cycle limit applies to each individual erase block in the flash device.

USB EDC Vertical 2ME uses a static wear-leveling algorithm to ensure that consecutive writes of a specific

sector are not written physically to the same page/block in the flash. This spreads flash media usage evenly across all pages, thereby extending flash lifetime.

## 2.4 Bad Blocks Management

Bad Blocks are blocks that contain one or more invalid bits whose reliability are not guaranteed. The Bad Blocks may be presented while the SSD is shipped, or may generate during the life time of the SSD. When the Bad Blocks is detected, it will be flagged, and not be used anymore. The SSD implement Bad Blocks management and replacement, Error Correct Code to avoid data error occurred. The functions will be enabled automatically to transfer data from Bad Blocks to spare blocks, and correct error bit. After the reserved block less than 40, the SSD will be locked, and cannot be written anymore.



## 3. Specifications

### 3.1 CE and FCC Compatibility

USB EDC Vertical 2ME conforms to CE and FCC requirements.

### 3.2 RoHS Compliance

USB EDC Vertical 2ME is fully compliant with RoHS directive.

### 3.3 Environmental Specifications

#### 3.3.1 Temperature Ranges

Operating Temperature Range:

- Standard Grade: 0°C ~ +70°C
- Industrial Grade: -40°C ~ +85°C

Storage Temperature Range:

- Standard Grade: -55°C to +95°C

#### 3.3.2 Humidity

Relative Humidity: 10-95%, non-condensing

#### 3.3.3 Shock and Vibration

| Reliability      | Test Conditions                | Reference Standards |
|------------------|--------------------------------|---------------------|
| Vibration        | 7 Hz to 2K Hz, 20G, 3 axes     | IEC 68-2-6          |
| Mechanical Shock | Duration: 0.5ms, 1500G, 3 axes | IEC 68-2-27         |

Table 1: Shock/Vibration Testing for USB EDC Vertical 2ME

#### 3.3.4 Mean Time between Failures (MTBF)

Table 2 summarizes the MTBF prediction results for various USB EDC Vertical 2ME configurations. The analysis was performed using a RAM Commander™ failure rate prediction.

- Failure Rate: The total number of failures within an item population, divided by the total number of life units expended by that population, during a particular measurement interval under stated condition.
- Mean Time between Failures (MTBF): A basic measure of reliability for repairable items: The mean number of life units during which all parts of the item perform within their specified limits, during a particular measurement interval under stated conditions.

| Product              | Condition                 | MTBF (Hours) |
|----------------------|---------------------------|--------------|
| USB EDC Vertical 2ME | Telcordia SR-332 GB, 25°C | >3,000,000   |

Table 2: USB EDC Vertical 2ME MTBF

### 3.3.5 Terabyte Written (TBW)

| Parameter             | Value |
|-----------------------|-------|
| TBW(Sequential Write) |       |
| 04GB                  | 10.8  |
| 08GB                  | 21.6  |
| 16GB                  | 43.2  |
| 32GB                  | 86.4  |

Table 3: USB EDC Vertical 2ME TBW

### 3.4 Pin Assignment

USB EDC Vertical 2ME is designed within USB2.0 Interface. Particularly, its built-in power pin enables the device more compactable. Table 3 demonstrates USB EDC Vertical 2ME pin assignments.

| <b>Horizontal Type</b> |               |                |               |
|------------------------|---------------|----------------|---------------|
| <b>Pin No.</b>         | <b>Signal</b> | <b>Pin No.</b> | <b>Signal</b> |
| <b>1</b>               | +5VDC         | <b>2</b>       | NC            |
| <b>3</b>               | USB Data(-)   | <b>4</b>       | NC            |
| <b>5</b>               | USB Data(+)   | <b>6</b>       | NC            |
| <b>7</b>               | GND           | <b>8</b>       | NC            |
| <b>9</b>               | NC            | <b>10</b>      | NC            |

Table 4: USB EDC Vertical 2ME Pin Assignment

### 3.5 Mechanical Dimensions

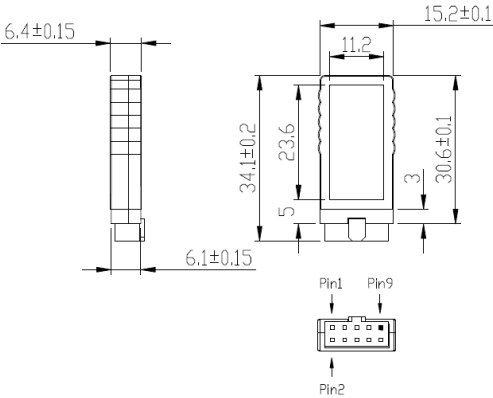

Figure 3: USB EDC Vertical 2ME mechanical dimensions

### 3.6 Weight

3g±2

### 3.7 Performance

| Product name         |                  | 4GB     | 8GB     | 16GB    | 32GB    |
|----------------------|------------------|---------|---------|---------|---------|
| USB EDC Vertical 2ME | Sequential Read  | 24 MB/S | 25 MB/S | 25 MB/S | 25 MB/S |
|                      | Sequential Write | 12 MB/S | 17 MB/S | 17 MB/S | 17 MB/S |

### 3.9 NAND Flash Memory

USB EDC Vertical 2ME uses Multi Level Cell (MLC) NAND flash memory, which is non-volatility and high reliability.

## 4. Electrical Specifications

### 4.1 Absolute Maximum Ratings

| Item                          | Symbol               | Rating     | Unit |
|-------------------------------|----------------------|------------|------|
| Storage Temperature           | T <sub>Storage</sub> | -55 ~ +95  | °C   |
| Ambient Operating Temperature | T <sub>a</sub>       | 0 ~ +70    | °C   |
| 3.3V supply voltage           | VCC33                | -0.3 ~ 3.6 | V    |
| 1.8V supply voltage           | VCC18                | -0.3 ~ 2   | V    |
| 3.3V buffer input voltage     | V <sub>in33</sub>    | -0.3 ~ 3.6 | V    |
| 3.3V/5V buffer input voltage  | V <sub>in335</sub>   | -0.3 ~ 5   | V    |
| 1.8V buffer input voltage     | V <sub>in18</sub>    | -0.3 ~ 2   | V    |

Table 5: USB EDC Absolute Maximum Ratings

### 4.2 Operating Conditions

| Item                  | Symbol             | Rating    | Unit |
|-----------------------|--------------------|-----------|------|
| USB 5V supply voltage | USBV <sub>in</sub> | 3.2 ~ 5.5 | V    |
| 3.3V supply voltage   | VDD33              | 3.0 ~ 3.6 | V    |
| 1.8V supply voltage   | VDD18              | 1.6 ~ 2   | V    |

Table 6: USB EDC Operating Conditions

### 4.3 Power Consumption

| Mode  | Power Consumption |
|---|-------------------|
| Read  | 170 mA (max.)     |
| Write   | 160 mA (max.)     |
| Idle  | 110 mA (max.)     |
| The power consumption is based on 32GB model. |                   |

Table 7: Power Consumption

#### 4.4 Device Parameters

USB EDC device parameters listed in Table 7.

| Capacity | LBA      | User capacity (MB) |
|----------|----------|--------------------|
| 4GB      | 7905280  | 3860               |
| 8GB      | 15810560 | 7720               |
| 16GB     | 31653888 | 15456              |
| 32GB     | 63373312 | 30944              |

Table 8: Device parameters

## 5. Part Number Rule

|   | 1    | 2           | 3 | 4 | 5 | 6 | 7        | 8 | 9 | 10       | 11  | 12 | 13         | 14              | 15          | 16      | 17    | 18 | 19              | 20 | 21 |
|---|------|-------------|---|---|---|---|----------|---|---|----------|---|----|------------|-----------------|-------------|---------|-------|----|-----------------|----|----|
|   | D    | E           | U | V | 1 | - | 0        | 8 | G | I        | 7   | 2  | R          | C               | 1           | S       | C     | -  | X               | X  | X  |
| Description   | Disk | Form Factor |   |   |   | - | Capacity |   |   | Category |   |    | Flash mode | Operation Temp. | PCB Version | Channel | Flash | -  | Customized Code |    |    |
| <b>Definition</b>   |      |             |   |   |   |   |          |   |   |          |   |    |            |                 |             |         |       |    |                 |    |    |
| <b>Code 1<sup>st</sup> (Disk)</b>                         |      |             |   |   |   |   |          |   |   |          | <b>Code 13<sup>th</sup> (Flash mode)</b>                      |    |            |                 |             |         |       |    |                 |    |    |
| D: Disk   |      |             |   |   |   |   |          |   |   |          | R: Sync. Flash (A19)  |    |            |                 |             |         |       |    |                 |    |    |
| <b>Code 2<sup>nd</sup> ~ 5<sup>th</sup> (Form Factor)</b> |      |             |   |   |   |   |          |   |   |          | <b>Code 14<sup>th</sup> (Operation Temperature)</b>           |    |            |                 |             |         |       |    |                 |    |    |
| EUV1: USB EDC Vertical                                    |      |             |   |   |   |   |          |   |   |          | C: Standard Grade (0°C ~ +70°C)                               |    |            |                 |             |         |       |    |                 |    |    |
| <b>Code 7<sup>th</sup> ~9<sup>th</sup> (Capacity)</b>     |      |             |   |   |   |   |          |   |   |          | W: Industrial Grade (-40°C ~ +85°C)                           |    |            |                 |             |         |       |    |                 |    |    |
| 04G: 4GB  |      |             |   |   |   |   |          |   |   |          | <b>Code 15<sup>th</sup> (PCB Version)</b>                     |    |            |                 |             |         |       |    |                 |    |    |
| 08G: 8GB  |      |             |   |   |   |   |          |   |   |          | 1: First Version  |    |            |                 |             |         |       |    |                 |    |    |
| 16G: 16GB   |      |             |   |   |   |   |          |   |   |          | <b>Code 16<sup>th</sup> (Channel)</b>                         |    |            |                 |             |         |       |    |                 |    |    |
| 32G: 32GB   |      |             |   |   |   |   |          |   |   |          | S: Single   |    |            |                 |             |         |       |    |                 |    |    |
| <b>Code 10<sup>th</sup> ~12<sup>th</sup> (Category)</b>   |      |             |   |   |   |   |          |   |   |          | <b>Code 17<sup>th</sup> (Flash)</b>                           |    |            |                 |             |         |       |    |                 |    |    |
| I72: USB Series   |      |             |   |   |   |   |          |   |   |          | C: Toshiba MLC  |    |            |                 |             |         |       |    |                 |    |    |
|   |      |             |   |   |   |   |          |   |   |          | <b>Code 19<sup>th</sup> ~21<sup>st</sup> (Customize code)</b> |    |            |                 |             |         |       |    |                 |    |    |

**REACH Declaration of Conformity****Manufacturer Product: All Innodisk EM Flash and Dram products**

1.宜鼎國際股份有限公司（以下稱本公司）特此保證此售予貴公司之產品，皆符合歐盟化學品法案(Registration , Evaluation and Authorization of Chemicals : REACH)之規定

(<http://www.echa.europa.eu/de/candidate-list-table> last updated: 16/05/2014)。所提供之產品包含：(1) 產品或產品所使用到的所有原物料；(2) 包裝材料；(3) 設計、生產及重工過程中所使用到的所有原物料。

We Innodisk Corporation hereby declare that our products are in compliance with the requirements according to the REACH Regulation

(<http://www.echa.europa.eu/de/candidate-list-table> last updated: 16/06/2014).

Products include : 1) Product and raw material used by the product ; 2) Packaging material ; 3) Raw material used in the process of design, production and rework

2.本公司同意因本保證書或與本保證書相關事宜有所爭議時，雙方宜友好協商，達成協議。

InnoDisk Corporation agrees that both parties shall settle any dispute arising from or in connection with this Declaration of Conformity by friendly negotiations.

**立 保 證 書 人 (Guarantor)**

Company name 公司名稱：InnoDisk Corporation 宜鼎國際股份有限公司

Company Representative 公司代表人：Richard Lee 李鐘亮

Company Representative Title 公司代表人職稱：CEO 執行長

Date 日期：2014 / 07 / 29



RoHS 自我宣告書 (RoHS Declaration of Conformity)

Manufacturer Product: All Innodisk EM Flash and Dram products

- 一、宜鼎國際股份有限公司（以下稱本公司）特此保證售予貴公司之所有產品，皆符合歐盟 2011/65/EU 關於 RoHS 之規範要求。

Innodisk Corporation declares that all products sold to the company, are complied with European Union RoHS Directive (2011/65/EU) requirement

- 二、本公司同意因本保證書或與本保證書相關事宜有所爭議時，雙方宜友好協商，達成協議。

Innodisk Corporation agrees that both parties shall settle any dispute arising from or in connection with this Declaration of Conformity by friendly negotiations.

| Name of hazardous substance    | Limited of RoHS ppm (mg/kg) |
|--------------------------------|-----------------------------|
| Cd                             | < 100 ppm                   |
| Pb                             | < 1000 ppm                  |
| Hg                             | < 1000 ppm                  |
| Chromium VI (Cr+6)             | < 1000 ppm                  |
| Polybromodiphenyl ether (PBDE) | < 1000 ppm                  |
| Polybrominated Biphenyls (PBB) | < 1000 ppm                  |

立保證書人 (Guarantor)

Company name 公司名稱：Innodisk Corporation 宜鼎國際股份有限公司

Company Representative 公司代表人：Richard Lee 李鍾亮

Company Representative Title 公司代表人職稱：CEO 執行長

Date 日期：2014 / 07 / 29



(Company Stamp/公司大小章)



## Verification of Compliance

Product Name : USB EDC Vertical 2SE/2ME  
Model Number : DEUV1-XXXI72 # % ※ & \*  
XXX : 512MB~16GB  
# : Flash Mode  
% : Temperature (C : Commercial Temp W : Industrial Temp  
E: Extended Temp)  
※ : PCB Version (A, B, C.... or 1, 2, 3...)  
& : Channel ( S : Single, D : Dual )  
\* : Flash Vender ( T : Micron SLC, S : Samsung SLC, N : Micron MLC  
B : Toshiba SLC, C: Toshiba MLC )

Applicant : InnoDisk Corporation  
Address : 9F, No.100, Sec. 1, Xintai 5th Rd., Xizhi Dist., New Taipei City 221,  
Taiwan

Report Number : O22-U070-1302-271  
Issue Date : April 1, 2013  
Applicable Standards : EN 55022:2010 Class B ITE  
AS/NZS CISPR22:2009 Class B ITE  
EN 55024:2010  
EN 61000-4-2:2009  
EN 61000-4-3:2006+A1:2008+A2:2010  
EN 61000-4-4:2004+A1:2010

Based on the EMC Directive 2004/108/EC and the specifications of the customer, one sample of the designated product has been tested in our laboratory and found to be in compliance with the EMC standards cited above.



TAF 0905  
FCC CAB Code TW1053  
NVLAP Lab Code 200575-0  
IC Code 4699A  
VCCI Accep. No. R-1527, C-1609, T-1441, G-10,  
C-4400, T-1334, G-614



**Central Research Technology Co.**  
EMC Test Laboratory  
11, Lane 41, Fushuen St., Jungshan Chiu,  
Taipei, Taiwan, 104, R.O.C.  
Tel : 886-2-25984568  
Fax: 886-2-25984546

(Tsun-Yu Shih/ General Manager)

Date: April 1, 2013

# Verification of Compliance

Product Name : USB EDC Vertical 2SE/2ME  
Model Number : DEUV1-XXXI72 # % ※ & \*  
XXX : 512MB~16GB  
# : Flash Mode  
% : Temperature (C : Commercial Temp W : Industrial Temp  
E : Extended Temp)  
※ : PCB Version (A, B, C.... or 1, 2, 3...)  
& : Channel (S : Single, D : Dual)  
\* : Flash Vender (T : Micron SLC, S : Samsung SLC, N : Micron MLC,  
B : Toshiba SLC, C : Toshiba MLC)

Applicant : InnoDisk Corporation  
Address : 9F, No.100, Sec. 1, Xintai 5th Rd., Xizhi Dist., New Taipei City 221,  
Taiwan  
Report Number : F-U070-1302-271  
Issue Date : April 1, 2013

Applicable Standards : FCC Part 15, Subpart B Class B ITE  
ANSI C63.4:2009  
Industry Canada ICES-003 Issue 5  
CSA-IEC CISPR22-10 Class B ITE

One sample of the designated product has been tested in our laboratory and found to be in compliance with the FCC rules cited above.



NVLAP LAB CODE 200575-0

TAF 0905

FCC CAB Code TW1053

IC Code 4699A

VCCI Accep. No. R-1527, C-1609, T-1441, G-10,  
C-4400, T-1334, G-614



**Central Research Technology Co.**

EMC Test Laboratory  
11, Lane 41, Fushuen St., Jungshan Chiu,  
Taipei, Taiwan, 104, R.O.C.  
Tel : 886-2-25984568  
Fax: 886-2-25984546

(Tsun-Yu Shih/ General Manager)

Date: April 1, 2013