



# UNIFIED SERVICES ROUTER USER MANUAL

DSR-150 / 150N / 250 / 250N / 500 / 500N /  
1000 / 1000N

VER. 1.05



SMALL BUSINESS GATEWAY SOLUTION

# User Manual

---

## *Unified Services Router*

D-Link Corporation

Copyright © 2012.

<http://www.dlink.com>

---

**User Manual**  
**DSR-150 / 150N /250 / 250N / DSR-500 / 500N / 1000 / 1000N**  
**Unified Services Router**  
**Version 1.05**

Copyright © 2012

### **Copyright Notice**

This publication, including all photographs, illustrations and software, is protected under international copyright laws, with all rights reserved. Neither this manual, nor any of the material contained herein, may be reproduced without written consent of the author.

### **Disclaimer**

The information in this document is subject to change without notice. The manufacturer makes no representations or warranties with respect to the contents hereof and specifically disclaim any implied warranties of merchantability or fitness for any particular purpose. The manufacturer reserves the right to revise this publication and to make changes from time to time in the content hereof without obligation of the manufacturer to notify any person of such revision or changes.

### **Limitations of Liability**

UNDER NO CIRCUMSTANCES SHALL D-LINK OR ITS SUPPLIERS BE LIABLE FOR DAMAGES OF ANY CHARACTER (E.G. DAMAGES FOR LOSS OF PROFIT, SOFTWARE RESTORATION, WORK STOPPAGE, LOSS OF SAVED DATA OR ANY OTHER COMMERCIAL DAMAGES OR LOSSES) RESULTING FROM THE APPLICATION OR IMPROPER USE OF THE D-LINK PRODUCT OR FAILURE OF THE PRODUCT, EVEN IF D-LINK IS INFORMED OF THE POSSIBILITY OF SUCH DAMAGES. FURTHERMORE, D-LINK WILL NOT BE LIABLE FOR THIRD-PARTY CLAIMS AGAINST CUSTOMER FOR LOSSES OR DAMAGES. D-LINK WILL IN NO EVENT BE LIABLE FOR ANY DAMAGES IN EXCESS OF THE AMOUNT D-LINK RECEIVED FROM THE END-USER FOR THE PRODUCT.

## Table of Contents

Chapter 1. Introduction.....	11
1.1 About this User Manual .....	12
1.2 Typographical Conventions .....	12
Chapter 2. Configuring Your Network: LAN Setup .....	13
2.1 LAN Configuration .....	13
2.1.1 LAN DHCP Reserved IPs .....	16
2.1.2 LAN DHCP Leased Clients.....	17
2.1.3 LAN Configuration in an IPv6 Network .....	18
2.1.4 Configuring IPv6 Router Advertisements .....	21
2.2 VLAN Configuration .....	23
2.2.1 Associating VLANs to ports .....	24
2.2.2 Multiple VLAN Subnets .....	26
2.2.3 VLAN configuration .....	27
2.3 Configurable Port: DMZ Setup .....	28
2.4 Universal Plug and Play (UPnP).....	29
2.5 Captive Portal.....	31
2.6 Captive portal setup.....	32
Chapter 3. Connecting to the Internet: WAN Setup .....	35
3.1 Internet Setup Wizard.....	35
3.2 WAN Configuration.....	36
3.2.1 WAN Port IP address .....	37
3.2.2 WAN DNS Servers .....	37
3.2.3 DHCP WAN .....	37
3.2.4 PPPoE .....	38
3.2.5 Russia L2TP and PPTP WAN .....	41
3.2.6 Russia Dual Access PPPoE.....	42
3.2.7 WAN Configuration in an IPv6 Network .....	43
3.2.8 Checking WAN Status.....	45
3.3 Bandwidth Controls .....	47
3.4 Features with Multiple WAN Links .....	49
3.4.1 Auto Failover .....	49
3.4.2 Load Balancing.....	50
3.4.3 Protocol Bindings .....	52
3.5 Routing Configuration.....	53
3.5.1 Routing Mode .....	53
3.5.2 Dynamic Routing (RIP) .....	56
3.5.3 Static Routing .....	57
3.5.4 OSPFv2 .....	58
3.5.5 OSPFv3 .....	60
3.5.6 6to4 Tunneling .....	62
3.5.7 ISATAP Tunnels .....	63
3.6 Configurable Port - WAN Option .....	64
3.7 WAN 3 (3G) Configuration.....	64
3.8 WAN Port Settings.....	66

Chapter 4.	Wireless Access Point Setup .....	68
4.1	Wireless Settings Wizard .....	68
4.1.1	Wireless Network Setup Wizard .....	69
4.1.2	Add Wireless Device with WPS .....	69
4.1.3	Manual Wireless Network Setup .....	70
4.2	Wireless Profiles.....	70
4.2.1	WEP Security.....	71
4.2.2	WPA or WPA2 with PSK .....	73
4.2.3	RADIUS Authentication .....	73
4.3	Creating and Using Access Points .....	75
4.3.1	Primary benefits of Virtual APs: .....	77
4.4	Tuning Radio Specific Settings .....	78
4.5	WMM.....	79
4.6	Wireless distribution system (WDS) .....	80
4.7	Advanced Wireless Settings .....	81
4.8	Wi-Fi Protected Setup (WPS).....	82
Chapter 5.	Securing the Private Network .....	85
5.1	Firewall Rules.....	85
5.2	Defining Rule Schedules .....	86
5.3	Configuring Firewall Rules.....	87
5.4	Configuring IPv6 Firewall Rules .....	92
5.4.1	Firewall Rule Configuration Examples.....	93
5.5	Security on Custom Services.....	97
5.6	ALG support .....	99
5.7	VPN Passthrough for Firewall .....	100
5.8	Application Rules .....	101
5.9	Web Content Filtering.....	102
5.9.1	Content Filtering .....	102
5.9.2	Approved URLs .....	103
5.9.3	Blocked Keywords .....	104
5.9.4	Export Web Filter .....	105
5.10	IP/MAC Binding .....	106
5.11	Intrusion Prevention (IPS).....	107
5.12	Protecting from Internet Attacks .....	108
Chapter 6.	IPsec / PPTP / L2TP VPN .....	111
6.1	VPN Wizard .....	113
6.2	Configuring IPsec Policies .....	115
6.2.1	Extended Authentication (XAUTH) .....	119
6.2.2	Internet over IPsec tunnel .....	120
6.3	Configuring VPN clients .....	120
6.4	PPTP / L2TP Tunnels.....	120
6.4.1	PPTP Tunnel Support .....	120
6.4.2	L2TP Tunnel Support .....	122
6.4.3	OpenVPN Support.....	123
6.4.4	OpenVPN Remote Network .....	125
6.4.5	OpenVPN Authentication .....	126

Chapter 7. SSL VPN .....	129
7.1 Groups and Users.....	131
7.1.1 Users and Passwords .....	137
7.2 Using SSL VPN Policies .....	138
7.2.1 Using Network Resources .....	141
7.3 Application Port Forwarding .....	142
7.4 SSL VPN Client Configuration .....	144
7.5 User Portal .....	147
7.5.1 Creating Portal Layouts .....	147
Chapter 8. Advanced Configuration Tools .....	150
8.1 USB Device Setup .....	150
8.2 USB share port .....	151
8.3 SMS service.....	153
8.4 Authentication Certificates .....	154
8.5 Advanced Switch Configuration .....	156
Chapter 9. Administration & Management .....	157
9.1 Configuration Access Control .....	157
9.1.1 Admin Settings .....	157
9.1.2 Remote Management.....	158
9.1.3 CLI Access.....	159
9.2 SNMP Configuration .....	159
9.3 Configuring Time Zone and NTP .....	161
9.4 Log Configuration.....	162
9.4.1 Defining What to Log .....	162
9.4.2 Sending Logs to E-mail or Syslog .....	167
9.4.3 Event Log Viewer in GUI .....	169
9.5 Backing up and Restoring Configuration Settings .....	170
9.6 Upgrading Router Firmware.....	171
9.7 Upgrading Router Firmware via USB.....	172
9.8 Dynamic DNS Setup .....	173
9.9 Using Diagnostic Tools .....	174
9.9.1 Ping.....	175
9.9.2 Trace Route .....	175
9.9.3 DNS Lookup .....	176
9.9.4 Router Options .....	176
9.10 Localization .....	177
Chapter 10. Router Status and Statistics.....	178
10.1 System Overview .....	178
10.1.1 Device Status .....	178
10.1.2 Resource Utilization .....	180
10.2 Traffic Statistics .....	183
10.2.1 Wired Port Statistics.....	183
10.2.2 Wireless Statistics.....	184
10.3 Active Connections.....	185
10.3.1 Sessions through the Router .....	185

10.3.2	Wireless Clients .....	187
10.3.3	LAN Clients .....	187
10.3.4	Active VPN Tunnels .....	188
Chapter 11.	Trouble Shooting .....	190
11.1	Internet connection .....	190
11.2	Date and time .....	192
11.3	Pinging to Test LAN Connectivity .....	192
11.3.1	Testing the LAN path from your PC to your router .....	192
11.3.2	Testing the LAN path from your PC to a remote device .....	193
11.4	Restoring factory-default configuration settings .....	194
Chapter 12.	Credits .....	195
Appendix A.	Glossary .....	196
Appendix B.	Factory Default Settings.....	199
Appendix C.	Standard Services Available for Port Forwarding & Firewall Configuration .....	200
Appendix D.	Log Output Reference .....	201
Appendix E.	RJ-45 Pin-outs.....	255
Appendix F.	Product Statement .....	256

## List of Figures

Figure 1: Setup page for LAN TCP/IP settings .....	15
Figure 2: LAN DHCP Reserved IPs .....	17
Figure 3: LAN DHCP Leased Clients .....	18
Figure 4: IPv6 LAN and DHCPv6 configuration .....	19
Figure 5: Configuring the Router Advertisement Daemon .....	22
Figure 6: IPv6 Advertisement Prefix settings .....	23
Figure 7: Adding VLAN memberships to the LAN .....	24
Figure 8: Port VLAN list .....	25
Figure 9: Configuring VLAN membership for a port .....	26
Figure 10: Multiple VLAN Subnets .....	27
Figure 11: VLAN Configuration .....	28
Figure 12: DMZ configuration .....	29
Figure 13: UPnP Configuration .....	30
Figure 14: Active Runtime sessions .....	32
Figure 15: Captive Portal Setup .....	33
Figure 16: Customized Captive Portal Setup .....	34
Figure 17: Internet Connection Setup Wizard .....	35
Figure 18: Manual WAN configuration .....	38
Figure 19: PPPoE configuration for standard ISPs .....	39
Figure 20: WAN configuration for Japanese Multiple PPPoE (part 1) .....	40
Figure 21: WAN configuration for Multiple PPPoE (part 2) .....	41
Figure 22: Russia L2TP ISP configuration .....	42
Figure 23: Russia Dual access PPPoE configuration .....	43
Figure 24: IPv6 WAN Setup page .....	44
Figure 25: Connection Status information for both WAN ports .....	46
Figure 26: List of Configured Bandwidth Profiles .....	47
Figure 27: Bandwidth Profile Configuration page .....	48
Figure 28: Traffic Selector Configuration .....	49
Figure 29: Load Balancing is available when multiple WAN ports are configured and Protocol Bindings have been defined .....	52
Figure 30: Protocol binding setup to associate a service and/or LAN source to a WAN and/or destination network .....	53
Figure 31: Routing Mode is used to configure traffic routing between WAN and LAN, as well as Dynamic routing (RIP) .....	55
Figure 32: Static route configuration fields .....	58



Figure 33: OSPFv2 configured parameters ..... 59

Figure 34: OSPFv2 configuration ..... 60

Figure 35: OSPFv3 configured parameters ..... 61

Figure 36: OSPFv3 configuration ..... 62

Figure 37: 6 to 4 tunneling ..... 63

Figure 38: ISATAP Tunnels Configuration ..... 64

Figure 39: WAN3 configuration for 3G internet ..... 66

Figure 40: Physical WAN port settings ..... 67

Figure 41: Wireless Network Setup Wizards ..... 69

Figure 42: List of Available Profiles shows the options available to secure the wireless link ..... 71

Figure 43: Profile configuration to set network security ..... 73

Figure 44: RADIUS server (External Authentication) configuration ..... 75

Figure 45: Virtual AP configuration ..... 76

Figure 46: List of configured access points (Virtual APs) shows one enabled access point on the radio, broadcasting its SSID ..... 77

Figure 47: Radio card configuration options ..... 78

Figure 48: Wi-Fi Multimedia ..... 79

Figure 49: Wireless Distribution System ..... 80

Figure 50: Advanced Wireless communication settings ..... 82

Figure 51: WPS configuration for an AP with WPA/WPA2 profile ..... 83

Figure 52: List of Available Firewall Rules ..... 86

Figure 53: List of Available Schedules to bind to a firewall rule ..... 87

Figure 54: Example where an outbound SNAT rule is used to map an external IP address (209.156.200.225) to a private DMZ IP address (10.30.30.30) ..... 90

Figure 55: The firewall rule configuration page allows you to define the To/From zone, service, action, schedules, and specify source/destination IP addresses as needed. .... 91

Figure 56: The IPv6 firewall rule configuration page allows you to define the To/From zone, service, action, schedules, and specify source/destination IP addresses as needed. .. 92

Figure 57: List of Available IPv6 Firewall Rules ..... 93

Figure 58: Schedule configuration for the above example. .... 96

Figure 59: List of user defined services. .... 98

Figure 60: Custom Services configuration ..... 98

Figure 61: Available ALG support on the router. .... 100

Figure 62: Passthrough options for VPN tunnels ..... 101

Figure 63: List of Available Application Rules showing 4 unique rules ..... 102

Figure 64: Content Filtering used to block access to proxy servers and prevent ActiveX controls from being downloaded..... 103

Figure 65: Two trusted domains added to the Approved URLs List ..... 104

Figure 66: One keyword added to the block list..... 105

Figure 67: Export Approved URL list ..... 106

Figure 68: The following example binds a LAN host’s MAC Address to an IP address served by DSR. If there is an IP/MAC Binding violation, the violating packet will be dropped and logs will be captured..... 107

Figure 69: Intrusion Prevention features on the router ..... 108

Figure 70: Protecting the router and LAN from internet attacks ..... 109

Figure 71: Example of Gateway-to-Gateway IPsec VPN tunnel using two DSR routers connected to the Internet..... 111

Figure 72: Example of three IPsec client connections to the internal network through the DSR IPsec gateway ..... 112

Figure 73: VPN Wizard launch screen ..... 113

Figure 74: IPsec policy configuration ..... 116

Figure 75: IPsec policy configuration continued (Auto policy via IKE) ..... 117

Figure 76: IPsec policy configuration continued (Auto / Manual Phase 2) ..... 119

Figure 77: PPTP tunnel configuration – PPTP Client..... 121

Figure 78: PPTP VPN connection status..... 121

Figure 79: PPTP tunnel configuration – PPTP Server ..... 122

Figure 80: L2TP tunnel configuration – L2TP Server..... 123

Figure 81: OpenVPN configuration ..... 125

Figure 82: OpenVPN Remote Network ..... 126

Figure 83: OpenVPN Authentication ..... 127

Figure 84: Example of clientless SSL VPN connections to the DSR ..... 130

Figure 85: List of groups ..... 131

Figure 86: User group configuration ..... 132

Figure 87: SSLVPN Settings..... 133

Figure 88: Group login policies options ..... 134

Figure 89: Browser policies options ..... 135

Figure 90: IP policies options..... 136

Figure 91: Available Users with login status and associated Group ..... 137

Figure 92: User configuration options ..... 138

Figure 93: List of SSL VPN polices (Global filter)..... 139

Figure 94: SSL VPN policy configuration ..... 140

Figure 95: List of configured resources, which are available to assign to SSL VPN policies ..... 142

Figure 96: List of Available Applications for SSL Port Forwarding ..... 144

Figure 97: SSL VPN client adapter and access configuration ..... 145

Figure 98: Configured client routes only apply in split tunnel mode..... 146

Figure 99: List of configured SSL VPN portals. The configured portal can then be associated with an authentication domain ..... 147

Figure 100: SSL VPN Portal configuration..... 149

Figure 101: USB Device Detection ..... 151

Figure 102: USB SharePort..... 152

Figure 103: SMS Service – Send SMS ..... 153

Figure 104: SMS Service – Receive SMS ..... 154

Figure 105: Certificate summary for IPsec and HTTPS management ..... 155

Figure 106: Advanced Switch Settings..... 156

Figure 107: User Login policy configuration ..... 157

Figure 108: Admin Settings ..... 158

Figure 109: Remote Management from the WAN ..... 159

Figure 110: SNMP Users, Traps, and Access Control ..... 160

Figure 111: SNMP system information for this router ..... 161

Figure 112: Date, Time, and NTP server setup ..... 162

Figure 113: Facility settings for Logging ..... 164

Figure 114: Log configuration options for traffic through router ..... 166

Figure 115: IPv6 Log configuration options for traffic through router ..... 167

Figure 116: E-mail configuration as a Remote Logging option..... 168

Figure 117: Syslog server configuration for Remote Logging (continued)..... 169

Figure 118: VPN logs displayed in GUI event viewer ..... 170

Figure 119: Restoring configuration from a saved file will result in the current configuration being overwritten and a reboot ..... 171

Figure 120: Firmware version information and upgrade option ..... 172

Figure 121: Firmware upgrade and configuration restore/backup via USB..... 173

Figure 122: Dynamic DNS configuration ..... 174

Figure 123: Router diagnostics tools available in the GUI ..... 175

Figure 124: Sample trace route output..... 176

Figure 125: Localization ..... 177

Figure 126: Device Status display ..... 179

Figure 127: Device Status display (continued) ..... 180

Figure 128: Resource Utilization statistics..... 181

Figure 129: Resource Utilization data (continued) ..... 182

Figure 130: Resource Utilization data (continued) ..... 183

Figure 131: Physical port statistics ..... 184

---

Figure 132: AP specific statistics.....	185
Figure 133: List of current Active Firewall Sessions .....	186
Figure 134: List of connected 802.11 clients per AP .....	187
Figure 135: List of LAN hosts .....	188
Figure 136: List of current Active VPN Sessions .....	189

# Chapter 1. Introduction

D-Link Unified Services Routers offer a secure, high performance networking solution to address the growing needs of small and medium businesses. Integrated high-speed IEEE 802.11n and 3G wireless technologies offer comparable performance to traditional wired networks, but with fewer limitations. Optimal network security is provided via features such as virtual private network (VPN) tunnels, IP Security (IPsec), Point-to-Point Tunneling Protocol (PPTP), Layer 2 Tunneling Protocol (L2TP), and Secure Sockets Layer (SSL). Empower your road warriors with clientless remote access anywhere and anytime using SSL VPN tunnels.

With the D-Link Unified Services Router you are able to experience a diverse set of benefits:

- Comprehensive Management Capabilities

The DSR-500, DSR-500N, DSR-1000 and DSR-1000N include dual-WAN Gigabit Ethernet which provides policy-based service management ensuring maximum productivity for your business operations. The failover feature maintains data traffic without disconnecting when a landline connection is lost. The Outbound Load Balancing feature adjusts outgoing traffic across two WAN interfaces and optimizes the system performance resulting in high availability. The second WAN port can be configured as a DMZ port allowing you to isolate servers from your LAN.

 DSR-150/150N/250 /250N have a single WAN interface, and thus it does not support Auto Failover and Load Balancing scenarios.

- Superior Wireless Performance

Designed to deliver superior wireless performance, the DSR-500N and DSR-1000N include 802.11 a/b/g/n, allowing for operation on either the 2.4 GHz or 5 GHz radio bands. Multiple In Multiple Out (MIMO) technology allows the DSR-500N and DSR-1000N to provide high data rates with minimal “dead spots” throughout the wireless coverage area.

 DSR-150N, 250N and DSR-500N supports the 2.4GHz radio band only.

- Flexible Deployment Options

The DSR-1000 / 1000N supports Third Generation (3G) Networks via an extendable USB 3G dongle. This 3G network capability offers an additional secure data connection for networks that provide critical services. The DSR-1000N can be configured to automatically switch to a 3G network whenever a physical link is lost.

- Robust VPN features

A fully featured virtual private network (VPN) provides your mobile workers and branch offices with a secure link to your network. The DSR-150/150N/250/250N, DSR-500/500N and DSR-1000 /1000N are capable of simultaneously managing 5, 5, 10, 20 Secure Sockets Layer (SSL) VPN tunnels respectively, empowering your mobile users by providing remote access to a

central corporate database. Site-to-site VPN tunnels use IP Security (IPsec) Protocol, Point-to-Point Tunneling Protocol (PPTP), or Layer 2 Tunneling Protocol (L2TP) to facilitate branch office connectivity through encrypted virtual links. The DSR-150/150N, DSR-250/250N, DSR-500/500N and DSR-1000/1000N support 10, 25, 35 and 75 simultaneous IPsec VPN tunnels respectively.

- Efficient D-Link Green Technology

As a concerned member of the global community, D-Link is devoted to providing eco-friendly products. D-Link Green WiFi and D-Link Green Ethernet save power and prevent waste. The D-Link Green WLAN scheduler reduces wireless power automatically during off-peak hours. Likewise the D-Link Green Ethernet program adjusts power usage based on the detected cable length and link status. In addition, compliance with RoHS (Restriction of Hazardous Substances) and WEEE (Waste Electrical and Electronic Equipment) directives make D-Link Green certified devices the environmentally responsible choice.

 Support for the 3G wireless WAN USB dongle is only available for DSR-1000 and DSR-1000N.

## 1.1 About this User Manual

This document is a high level manual to allow new D-Link Unified Services Router users to configure connectivity, setup VPN tunnels, establish firewall rules and perform general administrative tasks. Typical deployment and use case scenarios are described in each section. For more detailed setup instructions and explanations of each configuration parameter, refer to the online help that can be accessed from each page in the router GUI.

## 1.2 Typographical Conventions

The following is a list of the various terms, followed by an example of how that term is represented in this document:

- Product Name – D-Link Unified Services Router.
  - Model numbers DSR-500/500N/1000/1000N/250/250N/150/150N
- GUI Menu Path/GUI Navigation – ***Monitoring > Router Status***
- Important note – 

# Chapter 2. Configuring Your Network: LAN Setup

It is assumed that the user has a machine for management connected to the LAN to the router. The LAN connection may be through the wired Ethernet ports available on the router, or once the initial setup is complete, the DSR may also be managed through its wireless interface as it is bridged with the LAN. Access the router's graphical user interface (GUI) for management by using any web browser, such as Microsoft Internet Explorer or Mozilla Firefox:

- Go to **http://192.168.10.1** (default IP address) to display the router's management login screen.
- Default login credentials for the management GUI:
  - Username: **admin**
  - Password: **admin**

✎ If the router's LAN IP address was changed, use that IP address in the navigation bar of the browser to access the router's management UI.

## 2.1 LAN Configuration

### *Setup > Network Settings > LAN Configuration*

By default, the router functions as a Dynamic Host Configuration Protocol (DHCP) server to the hosts on the WLAN or LAN network. With DHCP, PCs and other LAN devices can be assigned IP addresses as well as addresses for DNS servers, Windows Internet Name Service (WINS) servers, and the default gateway. With the DHCP server enabled the router's IP address serves as the gateway address for LAN and WLAN clients. The PCs in the LAN are assigned IP addresses from a pool of addresses specified in this procedure. Each pool address is tested before it is assigned to avoid duplicate addresses on the LAN.

For most applications the default DHCP and TCP/IP settings are satisfactory. If you want another PC on your network to be the DHCP server or if you are manually configuring the network settings of all of your PCs, set the DHCP mode to 'none'. DHCP relay can be used to forward DHCP lease information from another LAN device that is the network's DHCP server; this is particularly useful for wireless clients.

Instead of using a DNS server, you can use a Windows Internet Naming Service (WINS) server. A WINS server is the equivalent of a DNS server but uses the NetBIOS protocol to resolve hostnames. The router includes the WINS server IP address in the DHCP configuration when acknowledging a DHCP request from a DHCP client.

You can also enable DNS proxy for the LAN. When this is enabled the router then as a proxy for all DNS requests and communicates with the ISP's DNS servers. When disabled all DHCP clients receive the DNS IP addresses of the ISP.

---

To configure LAN Connectivity, please follow the steps below:

1. In the LAN Setup page, enter the following information for your router:

- IP address (factory default: 192.168.10.1).

 If you change the IP address and click Save Settings, the GUI will not respond. Open a new connection to the new IP address and log in again. Be sure the LAN host (the machine used to manage the router) has obtained IP address from newly assigned pool (or has a static IP address in the router's LAN subnet) before accessing the router via changed IP address.

- Subnet mask (factory default: 255.255.255.0).

2. In the DHCP section, select the DHCP mode:

- None: the router's DHCP server is disabled for the LAN
- DHCP Server. With this option the router assigns an IP address within the specified range plus additional specified information to any LAN device that requests DHCP served addresses.
- DHCP Relay: With this option enabled, DHCP clients on the LAN can receive IP address leases and corresponding information from a DHCP server on a different subnet. Specify the Relay Gateway, and when LAN clients make a DHCP request it will be passed along to the server accessible via the Relay Gateway IP address.
- If DHCP is being enabled, enter the following DHCP server parameters:
- Starting and Ending IP Addresses: Enter the first and last continuous addresses in the IP address pool. Any new DHCP client joining the LAN is assigned an IP address in this range. The default starting address is 192.168.10.2. The default ending address is 192.168.10.100. These addresses should be in the same IP address subnet as the router's LAN IP address. You may wish to save part of the subnet range for devices with statically assigned IP addresses in the LAN.
- Primary and Secondary DNS servers: If configured domain name system (DNS) servers are available on the LAN enter their IP addresses here.
- WINS Server (optional): Enter the IP address for the WINS server or, if present in your network, the Windows NetBios server.



- Lease Time: Enter the time, in hours, for which IP addresses are leased to clients.
  - Relay Gateway: Enter the gateway address. This is the only configuration parameter required in this section when DHCP Relay is selected as its DHCP mode
3. In the DNS Host Name Mapping section:
    - Host Name: Provide a valid host name
    - IP address: Provide the IP address of the host name,
  4. In the LAN proxy section:
    - Enable DNS Proxy: To enable the router to act as a proxy for all DNS requests and communicate with the ISP's DNS servers, click the checkbox.
  5. Click Save Settings to apply all changes.

**Figure 1: Setup page for LAN TCP/IP settings**

The screenshot shows the 'LAN SETUP' page of a DSR-1000N router. The page is divided into several sections:

- LAN SETUP:** Contains a description and two buttons: 'Save Settings' and 'Don't Save Settings'.
- LAN TCP/IP Setup:** Includes input fields for IP Address (192.168.17.1) and Subnet Mask (255.255.255.0).
- DHCP:** Includes a dropdown for DHCP Mode (DHCP Server), and input fields for Starting IP Address (192.168.17.100), Ending IP Address (192.168.17.254), Primary DNS Server (192.168.17.38), Secondary DNS Server (192.168.98.4), Domain Name (DLink), WINS Server (192.168.17.38), Lease Time (24), and Relay Gateway.
- DNS Host Name Mapping:** A table with columns for #, Host Name, and IP Address. The first row shows #1 with empty input fields for Host Name and IP Address.

#	Host Name	IP Address
1	<input type="text"/>	<input type="text"/>

## 2.1.1 LAN DHCP Reserved IPs

### *Setup > Network Settings > LAN DHCP Reserved IPs*

This router DHCP server can assign TCP/IP configurations to computers in the LAN explicitly by adding client's network interface hardware address and the IP address to be assigned to that client in DHCP server's database. Whenever DHCP server receives a request from client, hardware address of that client is compared with the hardware address list present in the database, if an IP address is already assigned to that computer or device in the database, the customized IP address is configured otherwise an IP address is assigned to the client automatically from the DHCP pool.

**Computer Name:** The user defined name for the LAN host.

**IP Addresses:** The LAN IP address of a host that is reserved by the DHCP server.

**MAC Addresses:** The MAC address that will be assigned the reserved IP address when it is on the LAN.

**Associate with IP/MAC Binding:** When the user enables this option the Computer Name, IP and MAC addresses are associated with the IP/MAC binding.

The actions that can be taken on list of reserved IP addresses are:

**Select:** Selects all the reserved IP addresses in the list.

**Edit:** Opens the LAN DHCP Reserved IP Configuration page to edit the selected binding rule.

**Delete:** Deletes the selected IP address reservation(s)

**Add:** Opens the LAN DHCP Reserved IP Configuration page to add a new binding rule.

**Figure 2: LAN DHCP Reserved IPs**

DSR-1000N	SETUP	ADVANCED	TOOLS	STATUS								
Wizard ▶	<div style="background-color: #0070C0; color: white; padding: 5px; display: flex; justify-content: space-between;"> <span><b>DHCP RESERVED IPS</b></span> <span>LOGOUT</span> </div> <p style="background-color: #eee; padding: 5px; margin: 5px 0;">This page allows user to configure reserved IP Addresses for the DHCP server.</p> <div style="display: flex; justify-content: center; gap: 20px;"> <input type="button" value="Save Settings"/> <input type="button" value="Don't Save Settings"/> </div> <div style="background-color: #333; color: white; padding: 5px; margin-top: 5px;"><b>DHCP Reserved IPs for LAN</b></div> <table style="width: 100%; border-collapse: collapse;"> <tr> <td style="width: 60%;"><b>Computer Name:</b></td> <td><input type="text" value="DHQ"/></td> </tr> <tr> <td><b>IP Address:</b></td> <td><input type="text" value="192.168.10.101"/></td> </tr> <tr> <td><b>MAC Address:</b></td> <td><input type="text" value="00:00:AA:BB:04:00"/></td> </tr> <tr> <td><b>Associate with IP / MAC Binding:</b></td> <td><input checked="" type="checkbox"/></td> </tr> </table>				<b>Computer Name:</b>	<input type="text" value="DHQ"/>	<b>IP Address:</b>	<input type="text" value="192.168.10.101"/>	<b>MAC Address:</b>	<input type="text" value="00:00:AA:BB:04:00"/>	<b>Associate with IP / MAC Binding:</b>	<input checked="" type="checkbox"/>
<b>Computer Name:</b>					<input type="text" value="DHQ"/>							
<b>IP Address:</b>					<input type="text" value="192.168.10.101"/>							
<b>MAC Address:</b>					<input type="text" value="00:00:AA:BB:04:00"/>							
<b>Associate with IP / MAC Binding:</b>					<input checked="" type="checkbox"/>							

## 2.1.2 LAN DHCP Leased Clients

*Setup > Network Settings > LAN DHCP Leased Clients*

This page provides the list of clients connect to LAN DHCP server.

**Figure 3: LAN DHCP Leased Clients**

DSR-1000N	SETUP	ADVANCED	TOOLS	STATUS				
Wizard								
Internet Settings								
Wireless Settings								
Network Setting...								
DMZ Setup								
VPN Settings								
USB Settings								
VLAN Settings								
	<div style="background-color: #0056b3; color: white; padding: 5px;"> <b>DHCP LEASED CLIENTS</b> <span style="float: right;">LOGOUT</span> </div> <div style="border: 1px solid #ccc; padding: 5px; margin-top: 5px;">                     This table displays the list of DHCP clients connected to the LAN DHCP Server and to whom DHCP Server has given leases.                 </div> <div style="background-color: #333; color: white; padding: 5px; margin-top: 5px;"> <b>DHCP Leased Clients (LAN)</b> </div> <table border="1" style="width: 100%; border-collapse: collapse; margin-top: 5px;"> <thead> <tr> <th style="width: 50%;">IP Address</th> <th style="width: 50%;">MAC Address</th> </tr> </thead> <tbody> <tr> <td style="text-align: center;">192.168.10.100</td> <td style="text-align: center;">00:14:22:2b:88:f6</td> </tr> </tbody> </table>				IP Address	MAC Address	192.168.10.100	00:14:22:2b:88:f6
IP Address	MAC Address							
192.168.10.100	00:14:22:2b:88:f6							

**IP Addresses:** The LAN IP address of a host that matches the reserved IP list.

**MAC Addresses:** The MAC address of a LAN host that has a configured IP address reservation.

### 2.1.3 LAN Configuration in an IPv6 Network

*Advanced > IPv6 > IPv6 LAN > IPv6 LAN Config*

- (1) In IPv6 mode, the LAN DHCP server is enabled by default (similar to IPv4 mode). The DHCPv6 server will serve IPv6 addresses from configured address pools with the IPv6 Prefix Length assigned to the LAN.

IPv4 / IPv6 mode must be enabled in the *Advanced > IPv6 > IP mode* to enable IPv6 configuration options.

#### LAN Settings

The default IPv6 LAN address for the router is **fec0::1**. You can change this 128 bit IPv6 address based on your network requirements. The other field that defines the LAN settings for the router is the prefix length. The IPv6 network (subnet) is identified by the initial bits of the address called the prefix. By default this is **64** bits long. All hosts in the network have common initial bits for their IPv6 address; the number of common initial bits in the network’s addresses is set by the prefix length field.

Figure 4: IPv6 LAN and DHCPv6 configuration

DSR-1000N	SETUP	ADVANCED	TOOLS	STATUS
-----------	-------	----------	-------	--------

- Application Rules >
- Website Filter >
- Firewall Settings >
- Wireless Settings >
- Advanced Network >
- Routing >
- Certificates >
- Users >
- IP/MAC Binding >
- IPv6 >
- Radius Settings >
- Captive Portal >
- Switch Settings >
- Intel® AMT >

**IPv6 LAN CONFIG** LOGOUT

This page allows user to IPv6 related LAN configurations.

---

**LAN TCP/IP Setup**

**IPv6 Address:**

**IPv6 Prefix Length:**

---

**DHCPv6**

**DHCP Status:**

**DHCP Mode:**

**Domain Name:**

**Server Preference:**

**DNS Servers:**

**Primary DNS Server:**

**Secondary DNS Server:**

**Lease/Rebind Time:**  (Seconds)

**Prefix Delegation**

---

**List of IPv6 Address Pools**

	Start Address	End Address
<input type="checkbox"/>		

---

**List of Prefixes for Prefix Delegation**

	Prefix Address	Prefix Length
<input type="checkbox"/>		

⚠ If you change the IP address and click Save Settings, the GUI will not respond. Open a new connection to the new IP address and log in again. Be sure the LAN host (the machine used to manage the router) has obtained IP address from newly assigned pool (or has a static IP address in the router's LAN subnet) before accessing the router via changed IP address.

As with an IPv4 LAN network, the router has a DHCPv6 server. If enabled, the router assigns an IP address within the specified range plus additional specified information to any LAN PC that requests DHCP served addresses.

The following settings are used to configure the DHCPv6 server:

- **DHCP Mode:** The IPv6 DHCP server is either stateless or stateful. If stateless is selected an external IPv6 DHCP server is not required as the IPv6 LAN hosts are auto-configured by this router. In this case the router advertisement daemon (RADVD) must be configured on this device and ICMPv6 router discovery messages are used by the host for auto-configuration. There are no managed addresses to serve the LAN nodes. If stateful is selected the IPv6 LAN host will rely on an external DHCPv6 server to provide required configuration settings
- The domain name of the DHCPv6 server is an optional setting
- **Server Preference** is used to indicate the preference level of this DHCP server. DHCP advertise messages with the highest server preference value to a LAN host are preferred over other DHCP server advertise messages. The default is 255.
- The DNS server details can be manually entered here (primary/secondary options). An alternative is to allow the LAN DHCP client to receive the DNS server details from the ISP directly. By selecting Use DNS proxy, this router acts as a proxy for all DNS requests and communicates with the ISP's DNS servers (a WAN configuration parameter).
- **Primary and Secondary DNS servers:** If there is configured domain name system (DNS) servers available on the LAN enter the IP addresses here.
- **Lease/Rebind time** sets the duration of the DHCPv6 lease from this router to the LAN client.

## IPv6 Address Pools

This feature allows you to define the IPv6 delegation prefix for a range of IP addresses to be served by the gateway's DHCPv6 server. Using a delegation prefix you can automate the process of informing other networking equipment on the LAN of DHCP information specific for the assigned prefix.

## Prefix Delegation

The following settings are used to configure the Prefix Delegation:

- **Prefix Delegation:** Select this option to enable prefix delegation in DHCPv6 server. This option can be selected only in Stateless Address Auto Configuration mode of DHCPv6 server.

- Prefix Address: IPv6 prefix address in the DHCPv6 server prefix pool
- Prefix Length: Length prefix address

## 2.1.4 Configuring IPv6 Router Advertisements

Router Advertisements are analogous to IPv4 DHCP assignments for LAN clients, in that the router will assign an IP address and supporting network information to devices that are configured to accept such details. Router Advertisement is required in an IPv6 network is required for stateless auto configuration of the IPv6 LAN. By configuring the Router Advertisement Daemon on this router, the DSR will listen on the LAN for router solicitations and respond to these LAN hosts with router advertisements.

### **RADVD**

#### *Advanced > IPv6 > IPv6 LAN > Router Advertisement*

To support stateless IPv6 auto configuration on the LAN, set the RADVD status to Enable. The following settings are used to configure RADVD:

- Advertise Mode: Select Unsolicited Multicast to send router advertisements (RA's) to all interfaces in the multicast group. To restrict RA's to well-known IPv6 addresses on the LAN, and thereby reduce overall network traffic, select Unicast only.
- Advertise Interval: When advertisements are unsolicited multicast packets, this interval sets the maximum time between advertisements from the interface. The actual duration between advertisements is a random value between one third of this field and this field. The default is 30 seconds.
- RA Flags: The router advertisements (RA's) can be sent with one or both of these flags. Chose Managed to use the administered /stateful protocol for address auto configuration. If the Other flag is selected the host uses administered/stateful protocol for non-address auto configuration.
- Router Preference: this low/medium/high parameter determines the preference associated with the RADVD process of the router. This is useful if there are other RADVD enabled devices on the LAN as it helps avoid conflicts for IPv6 clients.
- MTU: The router advertisement will set this maximum transmission unit (MTU) value for all nodes in the LAN that are auto configured by the router. The default is 1500.
- Router Lifetime: This value is present in RA's and indicates the usefulness of this router as a default router for the interface. The default is 3600

seconds. Upon expiration of this value, a new RADVD exchange must take place between the host and this router.

**Figure 5: Configuring the Router Advertisement Daemon**

The screenshot displays the configuration page for the Router Advertisement Daemon (RADVD) on a Unified Services Router. The interface includes a top navigation bar with 'SETUP', 'ADVANCED', 'TOOLS', and 'STATUS' tabs. A left-hand navigation menu lists various settings, with 'IPv6' currently selected. The main configuration area is titled 'Router Advertisement Daemon (RADVD)' and contains the following settings:

- RADVD Status:** A dropdown menu set to 'Disable'.
- Advertise Mode:** A dropdown menu set to 'Unsolicited Multicast'.
- Advertise Interval:** A text input field containing the value '30'.
- RA Flags:** Two checkboxes: 'Managed' (unchecked) and 'Other' (checked).
- Router Preference:** A dropdown menu set to 'High'.
- MTU:** A text input field containing the value '1500'.
- Router Lifetime:** A text input field containing the value '3600'.

At the top of the configuration area, a red message reads: "Please Set IP Mode to IPv4/IPv6 in [Routing Mode Page](#) to configure this page." Below the message are two buttons: 'Save Settings' and 'Don't Save Settings'.

## Advertisement Prefixes

### *Advanced > IPv6 > IPv6 LAN > Advertisement Prefixes*

The router advertisements configured with advertisement prefixes allow this router to inform hosts how to perform stateless address auto configuration. Router advertisements contain a list of subnet prefixes that allow the router to determine neighbours and whether the host is on the same link as the router.

The following prefix options are available for the router advertisements:

- **IPv6 Prefix Type:** To ensure hosts support IPv6 to IPv4 tunnel select the 6to4 prefix type. Selecting Global/Local/ISATAP will allow the nodes to support all other IPv6 routing options
- **SLA ID:** The SLA ID (Site-Level Aggregation Identifier) is available when 6to4 Prefixes are selected. This should be the interface ID of the router's LAN interface used for router advertisements.



- IPv6 Prefix: When using Global/Local/ISATAP prefixes, this field is used to define the IPv6 network advertised by this router.
- IPv6 Prefix Length: This value indicates the number contiguous, higher order bits of the IPv6 address that define up the network portion of the address. Typically this is 64.
- Prefix Lifetime: This defines the duration (in seconds) that the requesting node is allowed to use the advertised prefix. It is analogous to DHCP lease time in an IPv4 network.

**Figure 6: IPv6 Advertisement Prefix settings**

DSR-1000N	SETUP	ADVANCED	TOOLS	STATUS
Application Rules ▶	<div style="background-color: #0070C0; color: white; padding: 5px; display: flex; justify-content: space-between;"> <span>ADVERTISEMENT PREFIXES</span> <span>LOGOUT</span> </div> <div style="border: 1px solid #ccc; padding: 10px; margin-top: 5px;">                     Description...  <div style="display: flex; justify-content: space-around; margin-top: 10px;"> <input type="button" value="Save Settings"/> <input type="button" value="Don't Save Settings"/> </div> </div> <div style="background-color: #333; color: white; padding: 5px; margin-top: 5px;">                     Advertise Prefixes Configuration                 </div> <div style="border: 1px solid #ccc; padding: 10px; margin-top: 5px;"> <p><b>IPv6 Prefix Type:</b> <input type="text" value="6to4"/></p> <p><b>SLA ID:</b> <input type="text"/></p> <p><b>IPv6 Prefix:</b> <input type="text"/></p> <p><b>IPv6 Prefix Length:</b> <input type="text"/></p> <p><b>Prefix Lifetime:</b> <input type="text"/> (Seconds)</p> </div>			
Website Filter ▶				
Firewall Settings ▶				
Wireless Settings ▶				
Advanced Network ▶				
Routing ▶				
Certificates				
Users ▶				
IP/MAC Binding				
IPv6 ▶				
Power Saving				

## 2.2 VLAN Configuration

The router supports virtual network isolation on the LAN with the use of VLANs. LAN devices can be configured to communicate in a sub network defined by VLAN identifiers. LAN ports can be assigned unique VLAN IDs so that traffic to and from that physical port can be isolated from the general LAN. VLAN filtering is particularly useful to limit broadcast packets of a device in a large network

VLAN support is disabled by default in the router. In the VLAN Configuration page, enable VLAN support on the router and then proceed to the next section to define the virtual network.

### *Setup > VLAN Settings > Available VLAN*

The Available VLAN page shows a list of configured VLANs by name and VLAN ID. A VLAN membership can be created by clicking the Add button below the List of Available VLANs.

A VLAN membership entry consists of a VLAN identifier and the numerical VLAN ID which is assigned to the VLAN membership. The VLAN ID value can be any

number from 2 to 4091. VLAN ID 1 is reserved for the default VLAN, which is used for untagged frames received on the interface. By enabling Inter VLAN Routing, you will allow traffic from LAN hosts belonging to this VLAN ID to pass through to other configured VLAN IDs that have Inter VLAN Routing enabled.

**Figure 7: Adding VLAN memberships to the LAN**

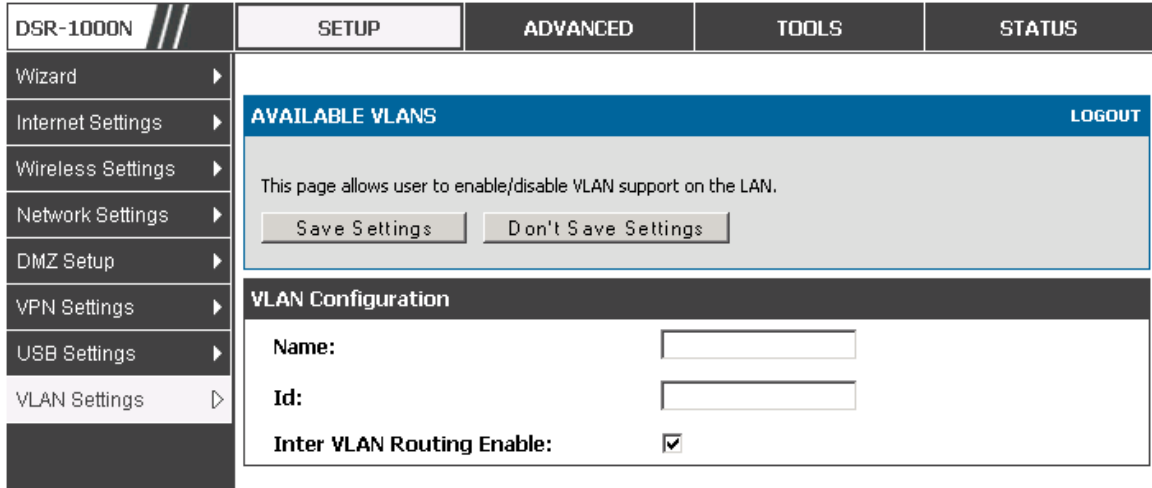

## 2.2.1 Associating VLANs to ports

In order to tag all traffic through a specific LAN port with a VLAN ID, you can associate a VLAN to a physical port.

### *Setup > VLAN Settings > Port VLAN*

VLAN membership properties for the LAN and wireless LAN are listed on this page. The VLAN Port table displays the port identifier, the mode setting for that port and VLAN membership information. The configuration page is accessed by selecting one of the four physical ports or a configured access point and clicking Edit.

The edit page offers the following configuration options:

- **Mode:** The mode of this VLAN can be General, Access, or Trunk. The default is access.
- In General mode the port is a member of a user selectable set of VLANs. The port sends and receives data that is tagged or untagged with a VLAN ID. If the data into the port is untagged, it is assigned the defined PVID. In the configuration from Figure 4, Port 3 is a General port with PVID 3, so untagged data into Port 3 will be assigned PVID 3. All tagged data sent out of the port with the same PVID will be untagged. This is mode is typically used with IP Phones that have dual Ethernet ports. Data coming from phone to the switch port on the router will be tagged. Data passing through the phone from a connected device will be untagged.

**Figure 8: Port VLAN list**

**PORT VLANS** LOGOUT

This page allows user to configure the port VLANs. A user can choose ports and can add them into a VLAN.

Port VLANs				
	Port Name	Mode	PVID	VLAN Membership
<input type="checkbox"/>	Port 1	Access	1	1
<input type="checkbox"/>	Port 2	Access	1	1
<input type="checkbox"/>	Port 3	Access	1	1
<input type="checkbox"/>	Port 4	Access	1	1

[E dit](#)

Wireless VLANs				
	SSID	Mode	PVID	VLAN Membership
<input type="checkbox"/>	DSR-1000N_1	Access	1	1

[E dit](#)

- In Access mode the port is a member of a single VLAN (and only one). All data going into and out of the port is untagged. Traffic through a port in access mode looks like any other Ethernet frame.
- In Trunk mode the port is a member of a user selectable set of VLANs. All data going into and out of the port is tagged. Untagged coming into the port is not forwarded, except for the default VLAN with PVID=1, which is untagged. Trunk ports multiplex traffic for multiple VLANs over the same physical link.
- Select PVID for the port when the General mode is selected.
- Configured VLAN memberships will be displayed on the VLAN Membership Configuration for the port. By selecting one more VLAN membership options for a General or Trunk port, traffic can be routed between the selected VLAN membership IDs

**Figure 9: Configuring VLAN membership for a port**

DSR-1000N	SETUP	ADVANCED	TOOLS	STATUS
Wizard	<div style="background-color: #0056b3; color: white; padding: 5px;"><b>VLAN CONFIGURATION</b> <span style="float: right;">LOGOUT</span></div> <div style="background-color: #e0e0e0; padding: 5px;">This page allows user to configure the port VLAN.</div> <div style="background-color: #333; color: white; padding: 5px;"><b>VLAN Configuration</b></div> <div style="padding: 5px;"> <p><b>Port Name:</b> Port 4</p> <p><b>Mode:</b> <input type="text" value="Access"/></p> <p><b>PVID:</b> <input type="text" value="1"/></p> <p style="text-align: right;"><input type="button" value="Apply"/> <input type="button" value="Cancel"/></p> </div> <div style="background-color: #333; color: white; padding: 5px;"><b>VLAN Membership Configuration</b></div> <div style="padding: 5px;"> <p><b>VLAN Membership:</b> 1 <input checked="" type="checkbox"/></p> <p style="text-align: right;"><input type="button" value="Apply"/> <input type="button" value="Cancel"/></p> </div>			
Internet Settings				
Wireless Settings				
Network Settings				
DMZ Setup				
VPN Settings				
USB Settings				
VLAN Settings				

## 2.2.2 Multiple VLAN Subnets

### *Setup > VLAN Settings > Multi VLAN Settings*

This page shows a list of available multi-VLAN subnets. Each configured VLAN ID can map directly to a subnet within the LAN. Each LAN port can be assigned a unique IP address and a VLAN specific DHCP server can be configured to assign IP address leases to devices on this VLAN.

**VLAN ID:** The PVID of the VLAN that will have all member devices be part of the same subnet range.

**IP Address:** The IP address associated with a port assigned this VLAN ID.

**Subnet Mask:** Subnet Mask for the above IP Address

**Figure 10: Multiple VLAN Subnets**

The screenshot shows the DSR-1000N web interface. On the left is a navigation menu with items: Wizard, Internet Settings, Wireless Settings, Network Setting..., DMZ Setup, VPN Settings, USB Settings, and VLAN Settings. The top navigation bar has tabs for SETUP, ADVANCED, TOOLS, and STATUS. The main content area is titled 'MULTI VLAN SUBNETS' and includes a 'LOGOUT' link. Below the title is a message: 'This page shows a list of available multi-vlan subnets. User can even edit the multi-vlans from this page.' A table titled 'MULTI VLAN SUBNET List' contains one entry with a checked checkbox, Vlan ID 1, IP Address 192.168.10.1, and Subnet Mask 255.255.255.0. An 'Edit' button is located below the table.

MULTI VLAN SUBNETS			
This page shows a list of available multi-vlan subnets. User can even edit the multi-vlans from this page.			
MULTI VLAN SUBNET List			
	Vlan ID	IP Address	Subnet Mask
<input checked="" type="checkbox"/>	1	192.168.10.1	255.255.255.0

[Edit](#)

### 2.2.3 VLAN configuration

*Setup > VLAN Settings > VLANconfiguration*

This page allows enabling or disabling the VLAN function on the router. Virtual LANs can be created in this router to provide segmentation capabilities for firewall rules and VPN policies. The LAN network is considered the default VLAN. Check the Enable VLAN box to add VLAN functionality to the LAN.

**Figure 11: VLAN Configuration**

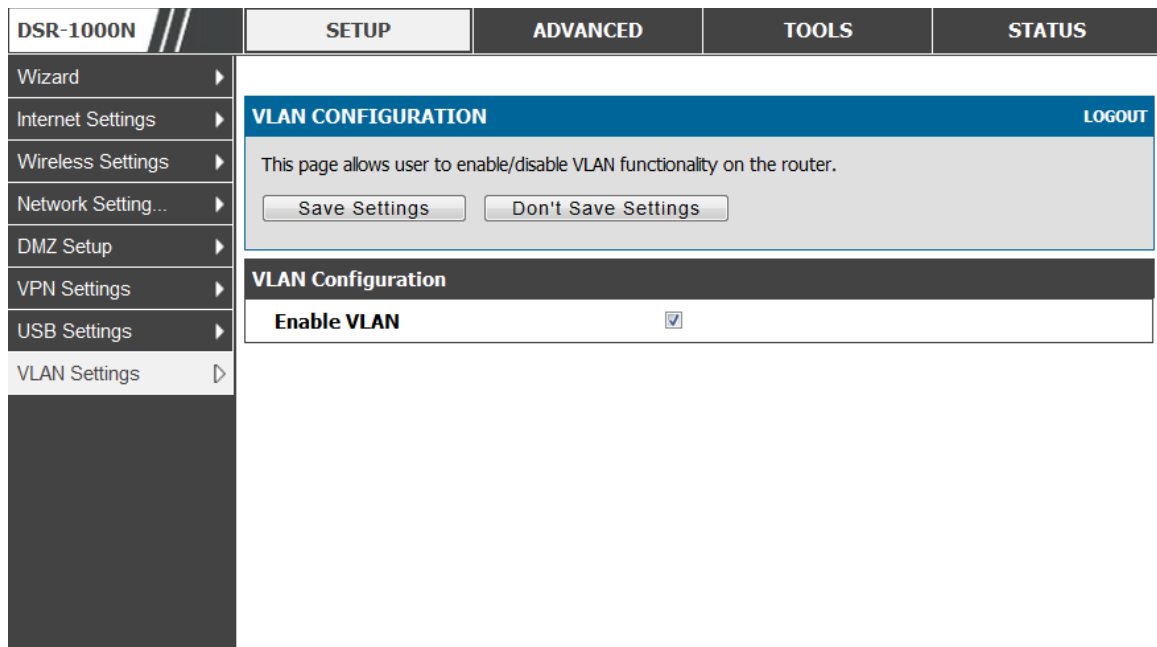

## 2.3 Configurable Port: DMZ Setup

 DSR-150/150N/250/250N does not have a configurable port – there is no DMZ support.

This router supports one of the physical ports to be configured as a secondary WAN Ethernet port or a dedicated DMZ port. A DMZ is a sub network that is open to the public but behind the firewall. The DMZ adds an additional layer of security to the LAN, as specific services/ports that are exposed to the internet on the DMZ do not have to be exposed on the LAN. It is recommended that hosts that must be exposed to the internet (such as web or email servers) be placed in the DMZ network. Firewall rules can be allowed to permit access specific services/ports to the DMZ from both the LAN or WAN. In the event of an attack to any of the DMZ nodes, the LAN is not necessarily vulnerable as well.

### *Setup > DMZ Setup > DMZ Setup Configuration*

DMZ configuration is identical to the LAN configuration. There are no restrictions on the IP address or subnet assigned to the DMZ port, other than the fact that it cannot be identical to the IP address given to the LAN interface of this gateway.

**Figure 12: DMZ configuration**

DSR-1000N	SETUP	ADVANCED	TOOLS	STATUS
Wizard				
Internet Settings	<b>DMZ SETUP</b> <span style="float: right;">LOGOUT</span>			
Wireless Settings	<p>The De-Militarized Zone (DMZ) is a network which, when compared to the LAN, has fewer firewall restrictions, by default. This zone can be used to host servers and give public access to them.</p> <p> <input type="button" value="Save Settings"/> <input type="button" value="Don't Save Settings"/> </p>			
Network Settings				
DMZ Setup				
VPN Settings	<b>DMZ Port Setup</b>			
USB Settings	<p><b>IP Address:</b> <input type="text" value="176.16.2.1"/></p> <p><b>Subnet Mask:</b> <input type="text" value="255.255.255.0"/></p>			
VLAN Settings	<b>DHCP for DMZ Connected Computers</b>			
	<p><b>DHCP Mode:</b> <input type="text" value="DHCP Server"/></p> <p><b>Starting IP Address:</b> <input type="text" value="176.16.2.100"/></p> <p><b>Ending IP Address:</b> <input type="text" value="176.16.2.254"/></p> <p><b>Primary DNS Server:</b> <input type="text"/></p> <p><b>Secondary DNS Server:</b> <input type="text"/></p> <p><b>WINS Server:</b> <input type="text"/></p> <p><b>Lease Time:</b> <input type="text" value="24"/></p> <p><b>Relay Gateway:</b> <input type="text"/></p>			
	<b>DMZ Proxy</b>			
	<b>Enable DNS Proxy:</b> <input checked="" type="checkbox"/>			

 In order to configure a DMZ port, the router's configurable port must be set to DMZ in the *Setup > Internet Settings > Configurable Port* page.

## 2.4 Universal Plug and Play (UPnP)

### *Advanced > Advanced Network > UPnP*

Universal Plug and Play (UPnP) is a feature that allows the router to discovery devices on the network that can communicate with the router and allow for auto configuration. If a network device is detected by UPnP, the router can open internal or external ports for the traffic protocol required by that network device.

Once UPnP is enabled, you can configure the router to detect UPnP-supporting devices on the LAN (or a configured VLAN). If disabled, the router will not allow for automatic device configuration.

Configure the following settings to use UPnP:

- Advertisement Period: This is the frequency that the router broadcasts UPnP information over the network. A large value will minimize network traffic but cause delays in identifying new UPnP devices to the network.
- Advertisement Time to Live: This is expressed in hops for each UPnP packet. This is the number of steps a packet is allowed to propagate before being discarded. Small values will limit the UPnP broadcast range. A default of 4 is typical for networks with few switches.

**Figure 13: UPnP Configuration**

The screenshot shows the UPnP configuration page in the DSR-1000N web interface. The left sidebar contains navigation options like Application Rules, Website Filter, Firewall Settings, etc. The top navigation bar has tabs for SETUP, ADVANCED, TOOLS, and STATUS. The main content area is titled 'UPnP' and includes a 'LOGOUT' link. Below the title, there is a descriptive paragraph about UPnP and two buttons: 'Save Settings' and 'Don't Save Settings'. The 'UPnP Enable' section contains a checked checkbox for 'Do you want to enable UPnP?', a 'LAN' dropdown menu, and two input fields: 'Advertisement Period' (set to 1800) and 'Advertisement Time To Live' (set to 4). At the bottom, there is a 'UPnP Port map Table' with columns for Active, Protocol, Int. Port, Ext. Port, and IP Address, and a 'Refresh' button.

**UPnP Port map Table**

The UPnP Port map Table has the details of UPnP devices that respond to the router’s advertisements. The following information is displayed for each detected device:

- Active: A yes/no indicating whether the port of the UPnP device that established a connection is currently active
- Protocol: The network protocol (i.e. HTTP, FTP, etc.) used by the DSR
- Int. Port (Internal Port): The internal ports opened by UPnP (if any)
- Ext. Port (External Port): The external ports opened by UPnP (if any)
- IP Address: The IP address of the UPnP device detected by this router

Click Refresh to refresh the portmap table and search for any new UPnP devices.



## 2.5 Captive Portal

 DSR-150/150N/250/250N does not have support for the Captive Portal feature.

LAN users can gain internet access via web portal authentication with the DSR. Also referred to as Run-Time Authentication, a Captive Portal is ideal for a web café scenario where users initiate HTTP connection requests for web access but are not interested in accessing any LAN services. Firewall policies underneath will define which users require authentication for HTTP access, and when a matching user request is made the DSR will intercept the request and prompt for a username / password. The login credentials are compared against the RunTimeAuth users in user database prior to granting HTTP access.

 Captive Portal is available for LAN users only and not for DMZ hosts.

### *Advanced > Captive Portal > Captive Portal Sessions*

The Active Runtime internet sessions through the router's firewall are listed in the below table. These users are present in the local or external user database and have had their login credentials approved for internet access. A 'Disconnect' button allows the DSR admin to selectively drop an authenticated user.

**Figure 14: Active Runtime sessions**

The screenshot shows the 'ADVANCED' tab selected in the top navigation bar. The main content area is titled 'CAPTIVE PORTAL SESSIONS' and includes a 'LOGOUT' link. Below this, a message states: 'This page displays a list of active run time sessions on your router.' A table titled 'List of Captive Portal Sessions' contains the following data:

<input type="checkbox"/>	Username	IP Adress
<input type="checkbox"/>	maheshb	192.168.17.38
<input type="checkbox"/>	sivakumar	192.168.17.41

Below the table is a 'Disconnect' button. On the right side of the interface, there is a 'Helpful Hints...' section with text: 'Use this page to monitor the runtime authentication sessions that are active on your router.' and a 'More...' link.

## 2.6 Captive portal setup

*Advanced > Captive Portal > Captive Portal Setup*

Captive Portal is a security mechanism to selectively provide authentication on certain interfaces. This page allows to manage the Policies and Profiles of CaptivePortal.

Figure 15: Captive Portal Setup

Captive Portal Policies: The List of Available CaptivePortal Policies are shown in this table.

Authentication Type: This allows in choosing the authentication mode, type and redirection type.

List of Available Profiles: Any one of these profiles can be used for Captive Portal Login page while enabling Captive Portal.

Figure 16: Customized Captive Portal Setup

DSR-1000N	SETUP	ADVANCED	TOOLS	STATUS
Application Rules	<div style="border: 1px solid black; padding: 5px;"> <div style="background-color: #0070C0; color: white; padding: 2px;"><b>CUSTOMIZED CAPTIVE PORTAL SETUP</b> <span style="float: right;">LOGOUT</span></div> <p>Captive Portal Login page is used for authentication on Captive Portal enabled interfaces.</p> <p style="text-align: center;"> <input type="button" value="Save Settings"/> <input type="button" value="Don't Save Settings"/> </p> </div>			
Website Filter				
Firewall Settin...				
Wireless Settings				
Advanced Networ...				
Routing				
Certificates				
Users				
IP/MAC Binding				
IPv6				
Radius Settings				
Captive Portal				
Switch Settings				
Intel® AMT				
<div style="background-color: #333; color: white; padding: 2px;"><b>General Details</b></div> <p><b>Profile Name:</b> default2</p> <p><b>Browser Title:</b> D-link Unified Services R</p> <p><b>Page Background Color:</b> Custom</p> <p><b>Custom Color: (#)</b> 040D18 (CF00CF)</p>				
<div style="background-color: #333; color: white; padding: 2px;"><b>Header Details</b></div> <p><b>Background:</b> Image</p> <p> <input checked="" type="radio"/> Default                 <input type="radio"/> Add                 <input type="radio"/> Add                 <input type="radio"/> Add                 <input type="radio"/> Add                 <input type="radio"/> Add             </p> <p><b>Header Background Color:</b> White</p> <p><b>Custom Color: (#)</b> (CF00CF)</p> <p><b>Header Caption:</b></p> <p><b>Caption Font:</b> Times New Roman</p> <p><b>Font Size:</b> Big</p> <p><b>Font Color:</b> Green</p>				
<div style="background-color: #333; color: white; padding: 2px;"><b>Login Details</b></div> <p><b>Login Section Title:</b> Authentication Details (Optional)</p> <p><b>Welcome Message:</b> Enter User Details (Optional)</p> <p><b>Error Message:</b> Invalid UserName or Password (Optional)</p>				
<div style="background-color: #333; color: white; padding: 2px;"><b>Advertisement Details</b></div> <p><b>Enable Advertisement:</b> <input checked="" type="checkbox"/></p> <p><b>Ad Place:</b> Right</p>				

Click “Add” in the Captive Portal setup page to allow defining customized captive portal login page information (Page Background Color, Header Details, Header Caption, Login Section Details, Advertisement Details, Footer Details and Captive Portal Header Image).

# Chapter 3. Connecting to the Internet: WAN Setup

This router has two WAN ports that can be used to establish a connection to the internet. The following ISP connection types are supported: DHCP, Static, PPPoE, PPTP, L2TP, 3G Internet (via USB modem).

It is assumed that you have arranged for internet service with your Internet Service Provider (ISP). Please contact your ISP or network administrator for the configuration information that will be required to setup the router.

## 3.1 Internet Setup Wizard

*Setup > Wizard > Internet*

The Internet Connection Setup Wizard is available for users new to networking. By going through a few straightforward configuration pages you can take the information provided by your ISP to get your WAN connection up and enable internet access for your network.

**Figure 17: Internet Connection Setup Wizard**

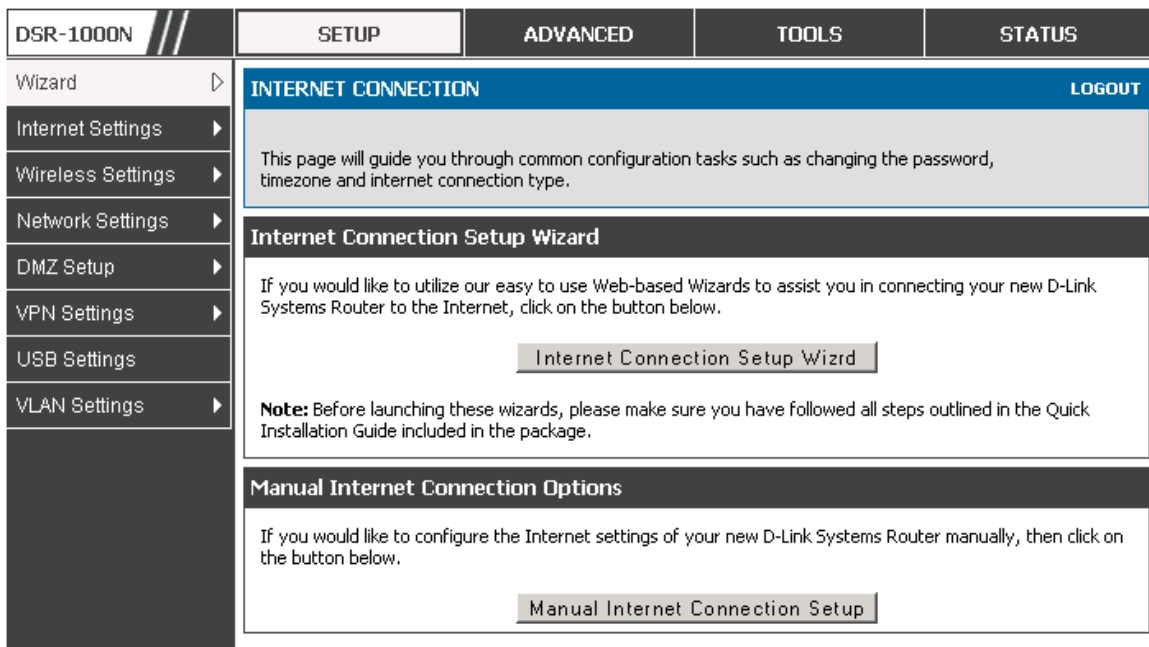

You can start using the Wizard by logging in with the administrator password for the router. Once authenticated set the time zone that you are located in, and then choose the type of ISP connection type: DHCP, Static, PPPoE, PPTP, L2TP. Depending on the connection type a username/password may be required to register this router with the ISP. In most cases the default settings can be used if the ISP did not specify that parameter. The last step in the Wizard is to click the Connect button, which confirms the settings by establishing a link with the ISP. Once connected, you can move on and configure other features in this router.

 3G Internet access with a USB modem is supported on WAN3. The Internet Connection Setup Wizard assists with the primary WAN port (WAN1) configuration only.

## 3.2 WAN Configuration

### *Setup > Internet Settings > WAN1 Setup*

You must either allow the router to detect WAN connection type automatically or configure manually the following basic settings to enable Internet connectivity:

- **ISP Connection type:** Based on the ISP you have selected for the primary WAN link for this router, choose Static IP address, DHCP client, Point-to-Point Tunneling Protocol (PPTP), Point-to-Point Protocol over Ethernet (PPPoE), Layer 2 Tunneling Protocol (L2TP). Required fields for the selected ISP type become highlighted. Enter the following information as needed and as provided by your ISP:
  - PPPoE Profile Name. This menu lists configured PPPoE profiles, particularly useful when configuring multiple PPPoE connections (i.e. for Japan ISPs that have multiple PPPoE support).
  - ISP login information. This is required for PPTP and L2TP ISPs.
    - User Name
    - Password
    - Secret (required for L2TP only)
  - MPPE Encryption: For PPTP links, your ISP may require you to enable Microsoft Point-to-Point Encryption (MPPE).
  - Split Tunnel (supported for PPTP and L2TP connection). This setting allows your LAN hosts to access internet sites over this WAN link while still permitting VPN traffic to be directed to a VPN configured on this WAN port.

 If split tunnel is enabled, DSR won't expect a default route from the ISP server. In such case, user has to take care of routing manually by configuring the routing from Static Routing page.

- **Connectivity Type:** To keep the connection always on, click Keep Connected. To log out after the connection is idle for a period of time (useful if your ISP costs are based on logon times), click Idle Timeout and enter the time, in minutes, to wait before disconnecting in the Idle Time field.

- **My IP Address:** Enter the IP address assigned to you by the ISP.
- **Server IP Address:** Enter the IP address of the PPTP or L2TP server.

 DSR-150/150N/250/250N doesn't have a dual WAN support.

### 3.2.1 WAN Port IP address

Your ISP assigns you an IP address that is either dynamic (newly generated each time you log in) or static (permanent). The IP Address Source option allows you to define whether the address is statically provided by the ISP or should be received dynamically at each login. If static, enter your IP address, IPv4 subnet mask, and the ISP gateway's IP address. PPTP and L2TP ISPs also can provide a static IP address and subnet to configure, however the default is to receive that information dynamically from the ISP.

### 3.2.2 WAN DNS Servers

The IP Addresses of WAN Domain Name Servers (DNS) are typically provided dynamically from the ISP but in some cases you can define the static IP addresses of the DNS servers. DNS servers map Internet domain names (example: www.google.com) to IP addresses. Click to indicate whether to get DNS server addresses automatically from your ISP or to use ISP-specified addresses. If its latter, enter addresses for the primary and secondary DNS servers. To avoid connectivity problems, ensure that you enter the addresses correctly.

### 3.2.3 DHCP WAN

For DHCP client connections, you can choose the MAC address of the router to register with the ISP. In some cases you may need to clone the LAN host's MAC address if the ISP is registered with that LAN host.

**Figure 18: Manual WAN configuration**

DSR-1000N	SETUP	ADVANCED	TOOLS	STATUS	HELP								
Content-type: text/html													
Wizard	<div style="border: 1px solid black; padding: 5px;"> <div style="display: flex; justify-content: space-between; align-items: center;"> <span><b>WAN1 SETUP</b></span> <span>LOGOUT</span> </div> <p>This page allows you to set up your Internet connection. Ensure that you have the Internet connection information such as the IP Addresses, Account Information etc. This information is usually provided by your ISP or network administrator.</p> <div style="display: flex; justify-content: center; gap: 10px;"> <input type="button" value="Save Settings"/> <input type="button" value="Don't Save Settings"/> </div> </div>												
Internet Settings													
Wireless Settings													
Network Settings													
DMZ Setup													
VPN Settings													
USB Settings													
VLAN Settings													
	<div style="border: 1px solid black; padding: 5px;"> <div style="background-color: #333; color: white; padding: 2px;"><b>ISP Connection Type</b></div> <table style="width: 100%; border-collapse: collapse;"> <tr> <td style="width: 40%;"><b>ISP Connection Type:</b></td> <td><input type="text" value="Static IP"/></td> </tr> <tr> <td><b>IP Address:</b></td> <td><input type="text" value="192.168.1.204"/></td> </tr> <tr> <td><b>IP Subnet Mask:</b></td> <td><input type="text" value="255.255.255.0"/></td> </tr> <tr> <td><b>Gateway IP Address:</b></td> <td><input type="text" value="192.168.1.2"/></td> </tr> </table> </div>					<b>ISP Connection Type:</b>	<input type="text" value="Static IP"/>	<b>IP Address:</b>	<input type="text" value="192.168.1.204"/>	<b>IP Subnet Mask:</b>	<input type="text" value="255.255.255.0"/>	<b>Gateway IP Address:</b>	<input type="text" value="192.168.1.2"/>
<b>ISP Connection Type:</b>	<input type="text" value="Static IP"/>												
<b>IP Address:</b>	<input type="text" value="192.168.1.204"/>												
<b>IP Subnet Mask:</b>	<input type="text" value="255.255.255.0"/>												
<b>Gateway IP Address:</b>	<input type="text" value="192.168.1.2"/>												
	<div style="border: 1px solid black; padding: 5px;"> <div style="background-color: #333; color: white; padding: 2px;"><b>Domain Name System (DNS) Servers</b></div> <table style="width: 100%; border-collapse: collapse;"> <tr> <td style="width: 40%;"><b>Primary DNS Server:</b></td> <td><input type="text" value="192.168.1.2"/></td> </tr> <tr> <td><b>Secondary DNS Server:</b></td> <td><input type="text" value="192.168.1.16"/></td> </tr> </table> </div>					<b>Primary DNS Server:</b>	<input type="text" value="192.168.1.2"/>	<b>Secondary DNS Server:</b>	<input type="text" value="192.168.1.16"/>				
<b>Primary DNS Server:</b>	<input type="text" value="192.168.1.2"/>												
<b>Secondary DNS Server:</b>	<input type="text" value="192.168.1.16"/>												
	<div style="border: 1px solid black; padding: 5px;"> <div style="background-color: #333; color: white; padding: 2px;"><b>MAC Address</b></div> <table style="width: 100%; border-collapse: collapse;"> <tr> <td style="width: 40%;"><b>MAC Address Source:</b></td> <td><input type="text" value="Use this MAC Address"/></td> </tr> <tr> <td><b>MAC Address:</b></td> <td><input type="text" value="00:0b:bb:7b:ce:51"/></td> </tr> </table> </div>					<b>MAC Address Source:</b>	<input type="text" value="Use this MAC Address"/>	<b>MAC Address:</b>	<input type="text" value="00:0b:bb:7b:ce:51"/>				
<b>MAC Address Source:</b>	<input type="text" value="Use this MAC Address"/>												
<b>MAC Address:</b>	<input type="text" value="00:0b:bb:7b:ce:51"/>												

### 3.2.4 PPPoE

*Setup > Internet Settings*

The PPPoE ISP settings are defined on the WAN Configuration page. There are two types of PPPoE ISP's supported by the DSR: the standard username/password PPPoE and Japan Multiple PPPoE.



**Figure 19: PPPoE configuration for standard ISPs**

DSR-1000N	SETUP	ADVANCED	TOOLS	STATUS
Internet Settings	<b>WAN1 SETUP</b>			LOGOUT
Wireless Settings	<p>This page allows you to set up your Internet connection. Ensure that you have the Internet connection information such as the IP Addresses, Account Information etc. This information is usually provided by your ISP or network administrator.</p> <p>Save Settings    Don't Save Settings</p>			
Network Settings	<b>PPPoE Profile Configuration</b>			
DMZ Setup	<p><b>ISP Connection Type:</b> <input type="text" value="PPPoE (Username/Password)"/></p> <p><b>Address Mode:</b> <input checked="" type="radio"/> Dynamic IP <input type="radio"/> Static IP</p> <p><b>IP Address:</b> <input type="text" value="0.0.0.0"/></p> <p><b>IP Subnet Mask:</b> <input type="text" value="0.0.0.0"/></p> <p><b>User Name:</b> <input type="text" value="dlink"/></p> <p><b>Password:</b> <input type="password" value="••••"/></p> <p><b>Service:</b> <input type="text"/> (Optional)</p> <p><b>Authentication Type:</b> <input type="text" value="Auto-negotiate"/></p> <p><b>Reconnect Mode:</b> <input checked="" type="radio"/> Always On <input type="radio"/> On Demand</p> <p><b>Maximum Idle Time:</b> <input type="text" value="5"/></p>			
VPN Settings	<b>Domain Name System (DNS) Servers</b>			
USB Settings	<b>DNS Server Source:</b> <input type="text" value="Get Dynamically from ISP"/>			
VLAN Settings				

Most PPPoE ISP's use a single control and data connection, and require username / password credentials to login and authenticate the DSR with the ISP. The ISP connection type for this case is "PPPoE (Username/Password)". The GUI will prompt you for authentication, service, and connection settings in order to establish the PPPoE link.

For some ISP's, most popular in Japan, the use of "Japanese Multiple PPPoE" is required in order to establish concurrent primary and secondary PPPoE connections between the DSR and the ISP. The Primary connection is used for the bulk of data and internet traffic and the Secondary PPPoE connection carries ISP specific (i.e. control) traffic between the DSR and the ISP.

**Figure 20: WAN configuration for Japanese Multiple PPPoE (part 1)**

DSR-1000N	SETUP	ADVANCED	TOOLS	STATUS
-----------	-------	----------	-------	--------

Wizard

Internet Settings >

Wireless Settings >

Network Settings >

DMZ Setup >

VPN Settings >

USB Settings >

VLAN Settings >

**LOGOUT**

**WAN1 SETUP**

This page allows you to set up your Internet connection. Ensure that you have the Internet connection information such as the IP Addresses, Account Information etc. This information is usually provided by your ISP or network administrator.

**Primary PPPoE Profile Configuration**

**ISP Connection Type:** Japanese multiple PPPoE

**Address Mode:**  Dynamic IP  Static IP

**IP Address:** 0.0.0.0

**IP Subnet Mask:** 0.0.0.0

**User Name:** dlink

**Password:** .....

**Service:** (Optional)

**Authentication Type:** Auto-negotiate

**Reconnect Mode:**  Always On  On Demand

**Maximum Idle Time:** 5

**Primary PPPoE Domain Name System (DNS) Servers**

**DNS Server Source:** Get Dynamically from ISP

**Primary DNS Server:** 0.0.0.0

**Secondary DNS Server:** 0.0.0.0

There are a few key elements of a multiple PPPoE connection:

- Primary and secondary connections are concurrent
- Each session has a DNS server source for domain name lookup, this can be assigned by the ISP or configured through the GUI
- The DSR acts as a DNS proxy for LAN users
- Only HTTP requests that specifically identify the secondary connection's domain name (for example \*.flets) will use the secondary profile to access the content available through this secondary PPPoE terminal. All other HTTP / HTTPS requests go through the primary PPPoE connection.

When Japanese multiple PPPoE is configured and secondary connection is up, some predefined routes are added on that interface. These routes are needed to access the internal domain of the ISP where he hosts various services. These routes can even be configured through the static routing page as well.

**Figure 21: WAN configuration for Multiple PPPoE (part 2)**

Secondary PPPoE Profile Configuration	
<b>Address Mode:</b>	<input checked="" type="radio"/> Dynamic IP <input type="radio"/> Static IP
<b>IP Address:</b>	<input type="text" value="0.0.0.0"/>
<b>IP Subnet Mask:</b>	<input type="text" value="0.0.0.0"/>
<b>User Name:</b>	<input type="text" value="dlink"/>
<b>Password:</b>	<input type="password" value="*****"/>
<b>Service:</b>	<input type="text"/> (Optional)
<b>Authentication Type:</b>	Auto-negotiate <input type="button" value="v"/>
<b>Reconnect Mode:</b>	<input checked="" type="radio"/> Always On <input type="radio"/> On Demand
<b>Maximum Idle Time:</b>	<input type="text" value="5"/>
Secondary PPPoE Domain Name System (DNS) Servers	
<b>DNS Server Source:</b>	Get Dynamically from ISP <input type="button" value="v"/>
<b>Primary DNS Server:</b>	<input type="text" value="0.0.0.0"/>
<b>Secondary DNS Server:</b>	<input type="text" value="0.0.0.0"/>
Mac Address	
<b>MAC Address Source:</b>	Use Default Address <input type="button" value="v"/>
<b>MAC Address:</b>	<input type="text" value="00:00:00:00:00:00"/>

### 3.2.5 Russia L2TP and PPTP WAN

For Russia L2TP WAN connections, you can choose the address mode of the connection to get an IP address from the ISP or configure a static IP address provided by the ISP. For DHCP client connections, you can choose the MAC address of the router to register with the ISP. In some cases you may need to clone the LAN host's MAC address if the ISP is registered with that LAN host.

Figure 22: Russia L2TP ISP configuration

DSR-1000N	SETUP	ADVANCED	TOOLS	STATUS	HELP
Content-type: text/html					
Wizard	<div style="border: 1px solid black; padding: 5px;"> <div style="background-color: #0070C0; color: white; padding: 2px;"><b>WAN1 SETUP</b> <span style="float: right;">LOGOUT</span></div> <p>This page allows you to set up your Internet connection. Ensure that you have the Internet connection information such as the IP Addresses, Account Information etc. This information is usually provided by your ISP or network administrator.</p> <p style="text-align: center;"> <input type="button" value="Save Settings"/> <input type="button" value="Don't Save Settings"/> </p> </div>				
Internet Settings					
Wireless Settings					
Network Settings					
DMZ Setup					
VPN Settings	<div style="border: 1px solid black; padding: 5px;"> <div style="background-color: #333; color: white; padding: 2px;"><b>ISP Connection Type</b></div> <p><b>ISP Connection Type:</b> <input type="text" value="L2TP (Username/Password)"/></p> <p><b>Address Mode:</b> <input type="radio"/> Dynamic IP <input checked="" type="radio"/> Static IP</p> <p><b>IP Address:</b> <input type="text" value="192.168.1.41"/></p> <p><b>IP Subnet Mask:</b> <input type="text" value="255.255.255.0"/></p> <p><b>IP Gateway:</b> <input type="text" value="0.0.0.0"/></p> <p><b>Server Address:</b> <input type="text" value="192.168.1.84"/></p> <p><b>User Name:</b> <input type="text" value="teamf1"/></p> <p><b>Password:</b> <input type="password" value="*****"/></p> <p><b>Secret:</b> <input type="password" value="*****"/></p> <p><b>Split Tunnel:</b> <input type="checkbox"/></p> <p><b>Reconnect Mode:</b> <input checked="" type="radio"/> Always On <input type="radio"/> On Demand</p> <p><b>Maximum Idle Time:</b> <input type="text" value="1"/></p> </div>				
USB Settings					
VLAN Settings					
	<div style="border: 1px solid black; padding: 5px;"> <div style="background-color: #333; color: white; padding: 2px;"><b>Domain Name System (DNS) Servers</b></div> <p><b>DNS Server Source:</b> <input type="text" value="Get Dynamically from ISP"/></p> <p><b>Primary DNS Server:</b> <input type="text" value="0.0.0.0"/></p> <p><b>Secondary DNS Server:</b> <input type="text" value="0.0.0.0"/></p> </div>				
	<div style="border: 1px solid black; padding: 5px;"> <div style="background-color: #333; color: white; padding: 2px;"><b>MAC Address</b></div> <p><b>MAC Address Source:</b> <input type="text" value="Use this MAC Address"/></p> <p><b>MAC Address:</b> <input type="text" value="00:0b:bb:7b:ce:51"/></p> </div>				

### 3.2.6 Russia Dual Access PPPoE

For Russia dual access PPPoE connections, you can choose the address mode of the connection to get an IP address from the ISP or configure a static IP address provided by the ISP.

**Figure 23: Russia Dual access PPPoE configuration**

**WAN1 SETUP** LOGOUT

This page allows you to set up your Internet connection. Ensure that you have the Internet connection information such as the IP Addresses, Account Information etc. This information is usually provided by your ISP or network administrator.

---

**PPPoE Profile Configuration**

**ISP Connection Type:** Russian dual access PPPoE ▾

**Address Mode:**  Dynamic IP  Static IP

**IP Address:**

**IP Subnet Mask:**

**User Name:**

**Password:**

**Service:**  (Optional)

**Authentication Type:** Auto-negotiate ▾

**Reconnect Mode:**  Always On  On Demand

**Maximum Idle Time:**

---

**Domain Name System (DNS) Servers**

**DNS Server Source:** Get Dynamically from ISP ▾

**Primary DNS Server:**

### 3.2.7 WAN Configuration in an IPv6 Network

#### *Advanced > IPv6 > IPv6 WAN1 Config*

For IPv6 WAN connections, this router can have a static IPv6 address or receive connection information when configured as a DHCPv6 client. In the case where the ISP assigns you a fixed address to access the internet, the static configuration settings must be completed. In addition to the IPv6 address assigned to your router, the IPv6 prefix length defined by the ISP is needed. The default IPv6 Gateway address is the server at the ISP that this router will connect to for accessing the internet. The primary and secondary DNS servers on the ISP's IPv6 network are used for resolving internet addresses, and these are provided along with the static IP address and prefix length from the ISP.

When the ISP allows you to obtain the WAN IP settings via DHCP, you need to provide details for the DHCPv6 client configuration. The DHCPv6 client on the gateway can be either stateless or stateful. If a stateful client is selected the gateway will connect to the ISP's DHCPv6 server for a leased address. For stateless DHCP

there need not be a DHCPv6 server available at the ISP, rather ICMPv6 discover messages will originate from this gateway and will be used for auto configuration. A third option to specify the IP address and prefix length of a preferred DHCPv6 server is available as well.

Figure 24: IPv6 WAN Setup page

DSR-1000N	SETUP	ADVANCED	TOOLS	STATUS
Application Rules	<div style="border: 1px solid black; padding: 5px;"> <div style="background-color: #0070C0; color: white; padding: 2px;"><b>IPv6 WAN1 CONFIG</b> <span style="float: right;">LOGOUT</span></div> <p>This page allows user to IPv6 related WAN1 configurations.</p> <p style="text-align: center;"> <input type="button" value="Save Settings"/> <input type="button" value="Don't Save Settings"/> </p> <hr/> <div style="background-color: #333; color: white; padding: 2px;"><b>Internet Address</b></div> <p><b>IPv6:</b> <span style="border: 1px solid black; padding: 2px;">PPPoE</span></p> <div style="background-color: #333; color: white; padding: 2px;"><b>Static IP Address</b></div> <p><b>IPv6 Address:</b> <input type="text"/></p> <p><b>IPv6 Prefix Length:</b> <input type="text" value="64"/></p> <p><b>Default IPv6 Gateway:</b> <input type="text"/></p> <p><b>Primary DNS Server:</b> <input type="text"/></p> <p><b>Secondary DNS Server:</b> <input type="text"/></p> <div style="background-color: #333; color: white; padding: 2px;"><b>DHCPv6</b></div> <p><b>Stateless Address Auto Configuration:</b> <input checked="" type="radio"/></p> <p><b>Stateful Address Auto Configuration:</b> <input type="radio"/></p> <p><b>Enable Prefix Delegation</b> <input checked="" type="checkbox"/></p> <div style="background-color: #333; color: white; padding: 2px;"><b>PPPoE</b></div> <p><b>User Name:</b> <input type="text" value="dlink"/></p> <p><b>Password:</b> <input type="password" value="*****"/></p> <p><b>Authentication Type:</b> <span style="border: 1px solid black; padding: 2px;">Auto-negotiate</span></p> <p><b>Dhcpv6 Options:</b> <span style="border: 1px solid black; padding: 2px;">disable dhcpv6</span></p> <p><b>Primary DNS Server:</b> <input type="text"/></p> <p><b>Secondary DNS Server:</b> <input type="text"/></p> </div>			
Website Filter				
Firewall Settings				
Wireless Settings				
Advanced Network				
Routing				
Certificates				
Users				
IP/MAC Binding				
IPv6				
Radius Settings				
Captive Portal				
Switch Settings				
Intel <sup>®</sup> AMT				

Prefix Delegation: Select this option to request router advertisement prefix from any available DHCPv6 servers available on the ISP, the obtained prefix is updated to the advertised prefixes on the LAN side. This option can be selected only in Statesless Address Auto Configuration mode of DHCPv6 Client.

When IPv6 is PPPoE type, the following PPPoE fields are enabled.

- Username: Enter the username required to log in to the ISP.

- Password: Enter the password required to login to the ISP.
- Authentication Type: The type of Authentication in use by the profile: Auto-Negotiate/PAP/CHAP/MS-CHAP/MS-CHAPv2.
- Dhcpv6 Options: The mode of Dhcpv6 client that will start in this mode: disable dhcpv6/stateless dhcpv6/stateful dhcpv6/stateless dhcpv6 with prefix delegation.
- Primary DNS Server: Enter a valid primary DNS Server IP Address.
- Secondary DNS Server: Enter a valid secondary DNS Server IP Address.

Click Save Settings to save your changes.

## 3.2.8 Checking WAN Status

### *Setup > Internet Settings > WAN1 Status*

The status and summary of configured settings for both WAN1, WAN2 and WAN3 are available on the WAN Status page. You can view the following key connection status information for each WAN port:

- Connection time: The connection uptime
- Connection type: Dynamic IP or Static IP
- Connection state: This is whether the WAN is connected or disconnected to an ISP. The Link State is whether the physical WAN connection is in place; the Link State can be UP (i.e. cable inserted) while the WAN Connection State is down.
- IP address / subnet mask: IP Address assigned
- Gateway IP address: WAN Gateway Address

Figure 25: Connection Status information for both WAN ports

DSR-1000N	SETUP	ADVANCED	TOOLS	STATUS
Wizard				
Internet Settings	<b>WAN1 STATUS</b>			LOGOUT
Wireless Settings	The page provides current information regarding the WAN1 interface. Along with the information a user can enable or disable his Internet connection from this page.			
Network Settings	<b>WAN1 Status (IPv4)</b>			
DMZ Setup	<b>MAC Address:</b>		00:0B:BB:7B:CE:51	
VPN Settings	<b>IPv4 Address:</b>		192.168.1.204 / 255.255.255.0	
USB Settings	<b>Wan State:</b>		UP(IPv4 and IPv6)	
VLAN Settings	<b>NAT (IPv4 only):</b>		Enabled	
	<b>IPv4 Connection Type:</b>		Static IP	
	<b>IPv4 Connection State:</b>		Connected	
	<b>Link State:</b>		LINK UP	
	<b>WAN Mode:</b>		Use only single WAN port: Dedicated WAN	
	<b>Gateway:</b>		192.168.1.2	
	<b>Primary DNS:</b>		192.168.1.2	
	<b>Secondary DNS:</b>		192.168.1.16	
	<input type="button" value="Disable"/>			
	<b>WAN1 Status (IPv6)</b>			
	<b>MAC Address:</b>		00:0B:BB:7B:CE:51	
	<b>IPv6 Address:</b>		2002::20b:dbff:fe7b:ce40/64, fe80::20b:bbff:fe7b:ce51/64	
	<b>Wan State:</b>		UP	
	<b>IPv6 Connection Type:</b>		Static IP	
	<b>IPv6 Connection State:</b>		Connected	
	<b>Gateway:</b>		2002::20b:dbff:fe7b:ce40	
	<b>Primary DNS:</b>		2002::20b:dbff:fe7b:ce50	
	<b>Secondary DNS:</b>		2002::280:48ff:fe46:1338	

The WAN status page allows you to Enable or Disable static WAN links. For WAN settings that are dynamically received from the ISP, you can Renew or Release the link parameters if required.



### 3.3 Bandwidth Controls

*Advanced > Advanced Network > Traffic Management > Bandwidth Profiles*

Bandwidth profiles allow you to regulate the traffic flow from the LAN to WAN 1 or WAN 2. This is useful to ensure that low priority LAN users (like guests or HTTP service) do not monopolize the available WAN’s bandwidth for cost-savings or bandwidth-priority-allocation purposes.

Bandwidth profiles configuration consists of enabling the bandwidth control feature from the GUI and adding a profile which defines the control parameters. The profile can then be associated with a traffic selector, so that bandwidth profile can be applied to the traffic matching the selectors. Selectors are elements like IP addresses or services that would trigger the configured bandwidth regulation.

**Figure 26: List of Configured Bandwidth Profiles**

DSR-1000N	SETUP	ADVANCED	TOOLS	STATUS									
Application Rules	<p><b>BANDWIDTH PROFILES</b> <span style="float:right">LOGOUT</span></p> <p>This page shows the list of configured bandwidth profiles. These profiles then can be used with the traffic selectors.</p> <p><input type="button" value="Save Settings"/> <input type="button" value="Don't Save Settings"/></p> <hr/> <p><b>Enable Bandwidth Profiles:</b> <input checked="" type="checkbox"/></p> <p><b>List of Bandwidth Profiles</b></p> <table border="1"> <thead> <tr> <th><input type="checkbox"/></th> <th>Name</th> <th>Bandwidth Rate / Priority</th> </tr> </thead> <tbody> <tr> <td><input type="checkbox"/></td> <td>Guests</td> <td>Low</td> </tr> <tr> <td><input type="checkbox"/></td> <td>Engineering</td> <td>1-1000000 Kbps</td> </tr> </tbody> </table> <p style="text-align: center;"><input type="button" value="Edit"/> <input type="button" value="Delete"/> <input type="button" value="Add"/></p>				<input type="checkbox"/>	Name	Bandwidth Rate / Priority	<input type="checkbox"/>	Guests	Low	<input type="checkbox"/>	Engineering	1-1000000 Kbps
<input type="checkbox"/>					Name	Bandwidth Rate / Priority							
<input type="checkbox"/>					Guests	Low							
<input type="checkbox"/>					Engineering	1-1000000 Kbps							
Website Filter													
Firewall Settings													
Wireless Settings													
Advanced Network													
Routing													
Certificates													
Users													
IP/MAC Binding													
IPv6													
Radius Settings													
Power Saving													

To create a new bandwidth profile, click Add in the List of Bandwidth Profiles. The following configuration parameters are used to define a bandwidth profile:

- Profile Name: This identifier is used to associate the configured profile to the traffic selector
- You can choose to limit the bandwidth either using priority or rate.
  - If using priority “Low”, “High”, and “Medium” can be selected. If there is a low priority profile associated with traffic selector A and a high priority profile associated with traffic selector B, then the WAN bandwidth allocation preference will be to traffic selector B packets .

- For finer control, the Rate profile type can be used. With this option the minimum and maximum bandwidth allowed by this profile can be limited.
- Choose the WAN interface that the profile should be associated with.

**Figure 27: Bandwidth Profile Configuration page**

DSR-1000N	SETUP	ADVANCED	TOOLS	STATUS
Application Rules	<div style="border: 1px solid black; padding: 5px;"> <div style="background-color: #0056b3; color: white; padding: 2px;"><b>BANDWIDTH PROFILES</b> <span style="float: right;">LOGOUT</span></div> <p style="text-align: center;">This page allows user to add a new bandwidth profile.</p> <div style="text-align: center;"> <input type="button" value="Save Settings"/> <input type="button" value="Don't Save Settings"/> </div> </div>			
Website Filter				
Firewall Settings				
Wireless Settings				
Advanced Network				
Routing				
Certificates				
Users				
IP/MAC Binding				
IPv6				
Radius Settings	<div style="border: 1px solid black; padding: 5px;"> <div style="background-color: #333; color: white; padding: 2px;"><b>Bandwidth Profile Configuration</b></div> <p><b>Name:</b> <input type="text"/></p> <p><b>Profile Type:</b> <input type="text" value="Priority"/></p> <p><b>Priority:</b> <input type="text" value="Low"/></p> <p><b>Minimum Bandwidth Rate:</b> <input type="text"/> (1 - Max. Bandwidth Kbps)</p> <p><b>Maximum Bandwidth Rate:</b> <input type="text"/> (100 - 1000000 Kbps)</p> <p><b>WAN Interface:</b> <input type="text" value="Dedicated WAN"/></p> </div>			
Power Saving				

*Advanced > Advanced Network > Traffic Management > Traffic Selectors*

Once a profile has been created it can then be associated with a traffic flow from the LAN to WAN. To create a traffic selector, click Add on the Traffic Selectors page. Traffic selector configuration binds a bandwidth profile to a type or source of LAN traffic with the following settings:

- Available profiles: Assign one of the defined bandwidth profiles
- Service: You can have the selected bandwidth regulation apply to a specific service (i.e. FTP) from the LAN. If you do not see a service that you want, you can configure a custom service through the *Advanced > Firewall Settings > Custom Services* page. To have the profile apply to all services, select ANY.
- Traffic Selector Match Type: this defines the parameter to filter against when applying the bandwidth profile. A specific machine on the LAN can be identified via IP address or MAC address, or the profile can apply to a LAN port or VLAN group. As well a wireless network can be selected by its BSSID for bandwidth shaping.

**Figure 28: Traffic Selector Configuration**

DSR-500N	SETUP	ADVANCED	TOOLS	STATUS																
Application Rules	<div style="border: 1px solid black; padding: 5px;"> <div style="background-color: #0070C0; color: white; padding: 2px;"><b>TRAFFIC SELECTORS</b> <span style="float: right;">LOGOUT</span></div> <p style="font-size: small; margin-top: 5px;">This page allows user to configure various traffic rules, to which bandwidth profiles can be attached.</p> <div style="margin-top: 5px;"> <input type="button" value="Save Settings"/> <input type="button" value="Don't Save Settings"/> </div> </div>																			
Website Filter																				
Firewall Settings																				
Wireless Settings																				
Advanced Network																				
Routing																				
Certificates																				
Users																				
IP/MAC Binding																				
IPv6																				
Radius Settings																				
Captive Portal																				
Switch Settings																				
Intel® AMT																				
					<div style="border: 1px solid black; padding: 5px;"> <div style="background-color: #333; color: white; padding: 2px;"><b>Traffic Selector Configuration</b></div> <table style="width: 100%; border-collapse: collapse;"> <tr> <td style="width: 60%;"><b>Available Profiles:</b></td> <td><input type="text" value="guests"/></td> </tr> <tr> <td><b>Service:</b></td> <td><input type="text" value="AIM"/></td> </tr> <tr> <td><b>Traffic Selector Match Type:</b></td> <td><input type="text" value="IP"/></td> </tr> <tr> <td><b>IP Address:</b></td> <td><input type="text"/></td> </tr> <tr> <td><b>MAC Address:</b></td> <td><input type="text"/></td> </tr> <tr> <td><b>Port Name:</b></td> <td><input type="text" value="Port 1"/></td> </tr> <tr> <td><b>BSSID:</b></td> <td><input type="text" value="ap1"/></td> </tr> <tr> <td><b>VLAN:</b></td> <td><input type="text" value="Default"/></td> </tr> </table> </div>				<b>Available Profiles:</b>	<input type="text" value="guests"/>	<b>Service:</b>	<input type="text" value="AIM"/>	<b>Traffic Selector Match Type:</b>	<input type="text" value="IP"/>	<b>IP Address:</b>	<input type="text"/>	<b>MAC Address:</b>	<input type="text"/>	<b>Port Name:</b>	<input type="text" value="Port 1"/>
<b>Available Profiles:</b>	<input type="text" value="guests"/>																			
<b>Service:</b>	<input type="text" value="AIM"/>																			
<b>Traffic Selector Match Type:</b>	<input type="text" value="IP"/>																			
<b>IP Address:</b>	<input type="text"/>																			
<b>MAC Address:</b>	<input type="text"/>																			
<b>Port Name:</b>	<input type="text" value="Port 1"/>																			
<b>BSSID:</b>	<input type="text" value="ap1"/>																			
<b>VLAN:</b>	<input type="text" value="Default"/>																			

### 3.4 Features with Multiple WAN Links

This router supports multiple WAN links. This allows you to take advantage of failover and load balancing features to ensure certain internet dependent services are prioritized in the event of unstable WAN connectivity on one of the ports.

*Setup > Internet Settings > WAN Mode*

To use Auto Failover or Load Balancing, WAN link failure detection must be configured. This involves accessing DNS servers on the internet or ping to an internet address (user defined). If required, you can configure the number of retry attempts when the link seems to be disconnected or the threshold of failures that determines if a WAN port is down.

#### 3.4.1 Auto Failover

In this case one of your WAN ports is assigned as the primary internet link for all internet traffic. The secondary WAN port is used for redundancy in case the primary link goes down for any reason. Both WAN ports (primary and secondary) must be configured to connect to the respective ISP's before enabling this feature. The secondary WAN port will remain unconnected until a failure is detected on the primary link (either port can be assigned as the primary). In the event of a failure on the primary port, all internet traffic will be rolled over to the backup port. When configured in Auto Failover mode, the link status of the primary WAN port is checked at regular intervals as defined by the failure detection settings.

Note that both WAN1, WAN2 and WAN3 can be configured as the primary internet link.

- Auto-Rollover using WAN port
- Primary WAN: Selected WAN is the primary link (WAN1/WAN2/WAN3)
- Secondary WAN: Selected WAN is the secondary link.

Failover Detection Settings: To check connectivity of the primary internet link, one of the following failure detection methods can be selected:

- DNS lookup using WAN DNS Servers: DNS Lookup of the DNS Servers of the primary link are used to detect primary WAN connectivity.
- DNS lookup using DNS Servers: DNS Lookup of the custom DNS Servers can be specified to check the connectivity of the primary link.
- Ping these IP addresses: These IP's will be pinged at regular intervals to check the connectivity of the primary link.
- Retry Interval is: The number tells the router how often it should run the above configured failure detection method.
- Failover after: This sets the number of retries after which failover is initiated.

## 3.4.2 Load Balancing

This feature allows you to use multiple WAN links (and presumably multiple ISP's) simultaneously. After configuring more than one WAN port, the load balancing option is available to carry traffic over more than one link. Protocol bindings are used to segregate and assign services over one WAN port in order to manage internet flow. The configured failure detection method is used at regular intervals on all configured WAN ports when in Load Balancing mode.

DSR currently support three algorithms for Load Balancing:

**Round Robin:** This algorithm is particularly useful when the connection speed of one WAN port greatly differs from another. In this case you can define protocol bindings to route low-latency services (such as VOIP) over the higher-speed link and let low-volume background traffic (such as SMTP) go over the lower speed link. Protocol binding is explained in next section.

**Spill Over:** If Spill Over method is selected, WAN1 acts as a dedicated link till a threshold is reached. After this, WAN2 will be used for new connections. You can configure spill-over mode by using following options:

- Load Tolerance: It is the percentage of bandwidth after which the router switches to secondary WAN.
- Max Bandwidth: This sets the maximum bandwidth tolerable by the primary WAN.

If the link bandwidth goes above the load tolerance value of max bandwidth, the router will spill-over the next connections to secondary WAN.

For example, if the maximum bandwidth of primary WAN is 1 Kbps and the load tolerance is set to 70. Now every time a new connection is established the bandwidth increases. After a certain number of connections say bandwidth reached

70% of 1Kbps, the new connections will be spilled-over to secondary WAN. The maximum value of load tolerance is 80 and the least is 20.

**Protocol Bindings:** Refer Section 3.4.3 for details

Load balancing is particularly useful when the connection speed of one WAN port greatly differs from another. In this case you can define protocol bindings to route low-latency services (such as VOIP) over the higher-speed link and let low-volume background traffic (such as SMTP) go over the lower speed link.

**Figure 29: Load Balancing is available when multiple WAN ports are configured and Protocol Bindings have been defined**

DSR-1000N	SETUP	ADVANCED	TOOLS	STATUS
-----------	-------	----------	-------	--------

Wizard

Internet Settings >

Wireless Settings >

Network Settings >

DMZ Setup >

VPN Settings >

USB Settings >

VLAN Settings >

LOGOUT

**WAN MODE**

This page allows user to configure the policies on the two WAN ports for Internet connection.

Save Settings    Don't Save Settings

---

**Port Mode**

Auto-Rollover using WAN port:

Primary WAN:

Secondary WAN:

Load Balancing:  Round Robin

Use only single WAN port:  WAN1

---

**WAN Failure Detection Method**

None:

DNS lookup using WAN DNS Servers:

DNS lookup using DNS Servers:

WAN1:

WAN2:

WAN3:

Ping these IP addresses:

WAN1:

WAN2:

WAN3:

Retry Interval is:  (Seconds)

Failover after:  (Failures)

---

**SPILOVER CONFIGURATION**

Load Tolerance:

Max Bandwidth:

### 3.4.3 Protocol Bindings

*Advanced > Routing > Protocol Bindings*

Protocol bindings are required when the Load Balancing feature is in use. Choosing from a list of configured services or any of the user-defined services, the type of traffic can be assigned to go over only one of the available WAN ports. For increased flexibility the source network or machines can be specified as well as the destination network or machines. For example the VOIP traffic for a set of LAN IP addresses can be assigned to one WAN and any VOIP traffic from the remaining IP

addresses can be assigned to the other WAN link. Protocol bindings are only applicable when load balancing mode is enabled and more than one WAN is configured.

**Figure 30: Protocol binding setup to associate a service and/or LAN source to a WAN and/or destination network**

DSR-1000N	SETUP	ADVANCED	TOOLS	STATUS
Application Rules ▶	<div style="background-color: #0070C0; color: white; padding: 5px;"><b>PROTOCOL BINDINGS</b> <span style="float: right;">LOGOUT</span></div> <p>This page allows user to add a new protocol binding rule for the WAN interfaces.</p> <p style="text-align: center;"> <input type="button" value="Save Settings"/> <input type="button" value="Don't Save Settings"/> </p>			
Website Filter ▶				
Firewall Settings ▶				
Wireless Settings ▶				
Advanced Network ▶				
Routing ▷				
Certificates				
Users ▶				
IP/MAC Binding				
IPv6 ▶				
Radius Settings	<div style="background-color: #333; color: white; padding: 5px;"><b>Protocol Binding Configuration</b></div> <p><b>Service:</b> <input type="text" value="ANY"/></p> <p><b>Local Gateway:</b> <input type="text" value="Dedicated WAN"/></p> <p><b>Source Network:</b> <input type="text" value="Any"/></p> <p><b>Start Address:</b> <input type="text"/></p> <p><b>End Address:</b> <input type="text"/></p> <p><b>Destination Network:</b> <input type="text" value="Any"/></p> <p><b>Start Address:</b> <input type="text"/></p> <p><b>End Address:</b> <input type="text"/></p>			
Power Saving				

## 3.5 Routing Configuration

Routing between the LAN and WAN will impact the way this router handles traffic that is received on any of its physical interfaces. The routing mode of the gateway is core to the behaviour of the traffic flow between the secure LAN and the internet.

### 3.5.1 Routing Mode

*Setup > Internet Settings > Routing Mode*

This device supports classical routing, network address translation (NAT), and transport mode routing.

- With classical routing, devices on the LAN can be directly accessed from the internet by their public IP addresses (assuming appropriate firewall settings). If your ISP has assigned an IP address for each of the computers that you use, select Classic Routing.

- NAT is a technique which allows several computers on a LAN to share an Internet connection. The computers on the LAN use a "private" IP address range while the WAN port on the router is configured with a single "public" IP address. Along with connection sharing, NAT also hides internal IP addresses from the computers on the Internet. NAT is required if your ISP has assigned only one IP address to you. The computers that connect through the router will need to be assigned IP addresses from a private subnet.
- Transparent routing between the LAN and WAN does not perform NAT. Broadcast and multicast packets that arrive on the LAN interface are switched to the WAN and vice versa, if they do not get filtered by firewall or VPN policies. To maintain the LAN and WAN in the same broadcast domain select Transparent mode, which allows bridging of traffic from LAN to WAN and vice versa, except for router-terminated traffic and other management traffic. All DSR features (such as 3G modem support) are supported in transparent mode assuming the LAN and WAN are configured to be in the same broadcast domain.

 NAT routing has a feature called "NAT Hair-pinning" that allows internal network users on the LAN and DMZ to access internal servers (eg. an internal FTP server) using their externally-known domain name. This is also referred to as "NAT loopback" since LAN generated traffic is redirected through the firewall to reach LAN servers by their external name.



**Figure 31: Routing Mode is used to configure traffic routing between WAN and LAN, as well as Dynamic routing (RIP)**

DSR-1000N	SETUP	ADVANCED	TOOLS	STATUS
Wizard	ROUTING MODE <span style="float: right;">LOGOUT</span>			
Internet Settings	<p>This page allows user to configure different routing modes like NAT, Classical Routing and Transparent. This page also allows to configure the RIP (Routing Information Protocol)</p> <p style="text-align: center;"> <input type="button" value="Save Settings"/> <input type="button" value="Don't Save Settings"/> </p>			
Wireless Settings	<b>Routing Mode between WAN and LAN</b>			
Network Settings	<p><b>NAT:</b> <input checked="" type="radio"/></p> <p><b>Classical Routing:</b> <input type="radio"/></p> <p><b>Transparent</b> <input type="radio"/></p>			
DMZ Setup	<b>Dynamic Routing (RIP)</b>			
VPN Settings	<p><b>RIP Direction:</b> <input type="text" value="None"/></p> <p><b>RIP Version:</b> <input type="text" value="Disabled"/></p>			
USB Settings	<b>Authentication for RIP-2B/2M</b>			
VLAN Settings	<p><b>Enable Authentication for RIP-2B/2M:</b> <input type="checkbox"/></p> <p><b>First Key Parameters</b></p> <p><b>MD5 Key Id:</b> <input type="text"/></p> <p><b>MD5 Auth Key:</b> <input type="text"/></p> <p><b>Not Valid Before:</b> <input type="text" value="MM DD YYYY - HH : MM : SS"/> / / - : : </p> <p><b>Not Valid After:</b> <input type="text" value="MM DD YYYY - HH : MM : SS"/> / / - : : </p> <p><b>Second Key Parameters</b></p> <p><b>MD5 Key Id:</b> <input type="text"/></p> <p><b>MD5 Auth Key:</b> <input type="text"/></p> <p><b>Not Valid Before:</b> <input type="text" value="MM DD YYYY - HH : MM : SS"/> / / - : : </p> <p><b>Not Valid After:</b> <input type="text" value="MM DD YYYY - HH : MM : SS"/> / / - : : </p>			

## 3.5.2 Dynamic Routing (RIP)

 DSR- 150/150N/250/250N does not support RIP.

### *Setup > Internet Settings > Routing Mode*

Dynamic routing using the Routing Information Protocol (RIP) is an Interior Gateway Protocol (IGP) that is common in LANs. With RIP this router can exchange routing information with other supported routers in the LAN and allow for dynamic adjustment of routing tables in order to adapt to modifications in the LAN without interrupting traffic flow.

The RIP direction will define how this router sends and receives RIP packets. Choose between:

- Both: The router both broadcasts its routing table and also processes RIP information received from other routers. This is the recommended setting in order to fully utilize RIP capabilities.
- Out Only: The router broadcasts its routing table periodically but does not accept RIP information from other routers.
- In Only: The router accepts RIP information from other routers, but does not broadcast its routing table.
- None: The router neither broadcasts its route table nor does it accept any RIP packets from other routers. This effectively disables RIP.
  - The RIP version is dependent on the RIP support of other routing devices in the LAN.
- Disabled: This is the setting when RIP is disabled.
- RIP-1 is a class-based routing version that does not include subnet information. This is the most commonly supported version.
- RIP-2 includes all the functionality of RIPv1 plus it supports subnet information. Though the data is sent in RIP-2 format for both RIP-2B and RIP-2M, the mode in which packets are sent is different. RIP-2B broadcasts data in the entire subnet while RIP-2M sends data to multicast addresses.

If RIP-2B or RIP-2M is the selected version, authentication between this router and other routers (configured with the same RIP version) is required. MD5 authentication is used in a first/second key exchange process. The authentication key validity lifetimes are configurable to ensure that the routing information exchange is with current and supported routers detected on the LAN.

## 3.5.3 Static Routing

*Advanced > Routing > Static Routing*

*Advanced > IPv6 > IPv6 Static Routing*

Manually adding static routes to this device allows you to define the path selection of traffic from one interface to another. There is no communication between this router and other devices to account for changes in the path; once configured the static route will be active and effective until the network changes.

The List of Static Routes displays all routes that have been added manually by an administrator and allows several operations on the static routes. The List of IPv4 Static Routes and List of IPv6 Static Routes share the same fields (with one exception):

- **Name:** Name of the route, for identification and management.
- **Active:** Determines whether the route is active or inactive. A route can be added to the table and made inactive, if not needed. This allows routes to be used as needed without deleting and re-adding the entry. An inactive route is not broadcast if RIP is enabled.
- **Private:** Determines whether the route can be shared with other routers when RIP is enabled. If the route is made private, then the route will not be shared in a RIP broadcast or multicast. This is only applicable for IPv4 static routes.
- **Destination:** the route will lead to this destination host or IP address.
- **IP Subnet Mask:** This is valid for IPv4 networks only, and identifies the subnet that is affected by this static route
- **Interface:** The physical network interface (WAN1, WAN2, WAN3, DMZ or LAN), through which this route is accessible.
- **Gateway:** IP address of the gateway through which the destination host or network can be reached.
- **Metric:** Determines the priority of the route. If multiple routes to the same destination exist, the route with the lowest metric is chosen.

**Figure 32: Static route configuration fields**

DSR-1000N	SETUP	ADVANCED	TOOLS	STATUS
Application Rules				
Website Filter				
Firewall Settings				
Wireless Settings				
Advanced Network				
Routing	<div style="border: 1px solid black; padding: 5px;"> <div style="background-color: #0070C0; color: white; padding: 2px;"><b>STATIC ROUTE CONFIGURATION</b> <span style="float: right;">LOGOUT</span></div> <p style="text-align: center;">This page allows user to add a new static route.</p> <p style="text-align: center;"> <input type="button" value="Save Settings"/> <input type="button" value="Don't Save Settings"/> </p> </div>			
Certificates	<div style="border: 1px solid black; padding: 5px;"> <div style="background-color: #333; color: white; padding: 2px;"><b>Static Route Configuration</b></div> <p><b>Route Name:</b> <input type="text"/></p> <p><b>Active:</b> <input type="checkbox"/></p> <p><b>Private:</b> <input type="checkbox"/></p> <p><b>Destination IP Address:</b> <input type="text"/></p> <p><b>IP Subnet Mask:</b> <input type="text"/></p> <p><b>Interface:</b> <input type="text" value="Dedicated WAN"/></p> <p><b>Gateway IP Address:</b> <input type="text"/></p> <p><b>Metric:</b> <input type="text"/></p> </div>			
Users				
IP/MAC Binding				
IPv6				
Radius Settings				
Power Saving				

### 3.5.4 OSPFv2

*Advanced > Routing > OSPF*

OSPF is an interior gateway protocol that routes Internet Protocol (IP) packets solely within a single routing domain. It gathers link state information from available routers and constructs a topology map of the network.

OSPF version 2 is a routing protocol which described in RFC2328 - OSPF Version 2. OSPF is IGP (Interior Gateway Protocols).OSPF is widely used in large networks such as ISP backbone and enterprise networks.

**Figure 33: OSPFv2 configured parameters**

DSR-1000N		SETUP	ADVANCED	TOOLS	STATUS																																													
Application Rules	▶	<b>OSPFV2</b> <span style="float: right;">LOGOUT</span> This page shows the OSPFv2 parameters configured on the router. User can also edit the OSPFv2 configured parameters.																																																
Website Filter	▶																																																	
Firewall Settin...	▶	<b>OSPFV2</b> <table border="1"> <thead> <tr> <th></th> <th>Interface</th> <th>Status</th> <th>Area</th> <th>Priority</th> <th>Hello Interval</th> <th>Dead Interval</th> <th>Cost</th> <th>Authentication Type</th> </tr> </thead> <tbody> <tr> <td><input type="checkbox"/></td> <td>LAN</td> <td>Disabled</td> <td></td> <td>1</td> <td>10</td> <td>40</td> <td>10</td> <td>None</td> </tr> <tr> <td><input type="checkbox"/></td> <td>WAN1</td> <td>Disabled</td> <td></td> <td>1</td> <td>10</td> <td>40</td> <td>10</td> <td>None</td> </tr> <tr> <td><input type="checkbox"/></td> <td>WAN2</td> <td>Disabled</td> <td></td> <td>1</td> <td>10</td> <td>40</td> <td>10</td> <td>None</td> </tr> <tr> <td><input type="checkbox"/></td> <td>WAN3</td> <td>Disabled</td> <td></td> <td>1</td> <td>10</td> <td>40</td> <td>10</td> <td>None</td> </tr> </tbody> </table>					Interface	Status	Area	Priority	Hello Interval	Dead Interval	Cost	Authentication Type	<input type="checkbox"/>	LAN	Disabled		1	10	40	10	None	<input type="checkbox"/>	WAN1	Disabled		1	10	40	10	None	<input type="checkbox"/>	WAN2	Disabled		1	10	40	10	None	<input type="checkbox"/>	WAN3	Disabled		1	10	40	10	None
	Interface					Status	Area	Priority	Hello Interval	Dead Interval	Cost	Authentication Type																																						
<input type="checkbox"/>	LAN	Disabled		1	10	40	10	None																																										
<input type="checkbox"/>	WAN1	Disabled		1	10	40	10	None																																										
<input type="checkbox"/>	WAN2	Disabled		1	10	40	10	None																																										
<input type="checkbox"/>	WAN3	Disabled		1	10	40	10	None																																										
Wireless Settings	▶																																																	
Advanced Networ...	▶	<input type="button" value="Edit"/>																																																
Routing	▷																																																	
Certificates																																																		
Users	▶																																																	
IP/MAC Binding																																																		
IPv6	▶																																																	
Radius Settings																																																		

**Interface:** The physical network interface on which OSPFv2 is Enabled/Disabled.

**Status:** This column displays the Enable/Disable state of OSPFv2 for a particular interface.

**Area:** The area to which the interface belongs. Two routers having a common segment; their interfaces have to belong to the same area on that segment. The interfaces should belong to the same subnet and have similar mask.

**Priority:** Helps to determine the OSPFv2 designated router for a network. The router with the highest priority will be more eligible to become Designated Router. Setting the value to 0, makes the router ineligible to become Designated Router. The default value is 1. Lower value means higher priority.

**HelloInterval:** The number of seconds for HelloInterval timer value. Setting this value, Hello packet will be sent every timer value seconds on the specified interface. This value must be the same for all routers attached to a common network. The default value is 10 seconds.

**DeadInterval:** The number of seconds that a device's hello packets must not have been seen before its neighbours declare the OSPF router down. This value must be the same for all routers attached to a common network. The default value is 40 seconds.

OSPF requires these intervals to be exactly the same between two neighbours. If any of these intervals are different, these routers will not become neighbours on a particular segment

**Cost:** The cost of sending a packet on an OSPFv2 interface.

**Authentication Type:** This column displays the type of authentication to be used for OSPFv2. If Authentication type is none the interface does not authenticate ospf packets. If Authentication Type is Simple then ospf packets are authenticated using simple text key. If Authentication Type is MD5 then the interface authenticates ospf packets with MD5 authentication.

**Figure 34: OSPFv2 configuration**

DSR-1000N	SETUP	ADVANCED	TOOLS	STATUS
Application Rules	<div style="border: 1px solid black; padding: 5px;"> <div style="background-color: #0070C0; color: white; padding: 2px;"><b>OSPFV2 CONFIGURATION</b> <span style="float: right;">LOGOUT</span></div> <div style="background-color: #f0f0f0; padding: 5px; margin-top: 5px;">                     This page allows the user to update the configured OSPFv2 parameters  <div style="text-align: center; margin-top: 5px;"> <input type="button" value="Save Settings"/> <input type="button" value="Don't Save Settings"/> </div> </div> </div>			
Website Filter				
Firewall Settin...				
Wireless Settings				
Advanced Networ...				
Routing				
Certificates				
Users				
IP/MAC Binding				
IPv6				
Radius Settings	<div style="border: 1px solid black; padding: 5px;"> <div style="background-color: #333; color: white; padding: 2px;"><b>Ospf2 Configuration</b></div> <div style="padding: 5px;"> <p><b>Ospf2 Enable:</b> <input checked="" type="checkbox"/></p> <p><b>Interface:</b> WAN2</p> <p><b>Area:</b> <input type="text"/></p> <p><b>Priority:</b> <input type="text" value="1"/></p> <p><b>Hello Interval:</b> <input type="text" value="10"/></p> <p><b>Dead Interval:</b> <input type="text" value="40"/></p> <p><b>Cost:</b> <input type="text" value="10"/></p> <p><b>Authentication Type:</b> Simple ▾</p> <p><b>Authentication Key:</b> <input type="text"/></p> <p><b>MD5 Key Id:</b> <input type="text"/></p> <p><b>MD5 Authentication Key :</b> <input type="text"/></p> </div> </div>			
Captive Portal				
Switch Settings				
Intel® AMT				

### 3.5.5 OSPFv3

*Advanced > IPv6 > OSPF*

Open Shortest Path First version 3 (OSPFv3) supports IPv6. To enable an OSPFv3 process on a router, you need to enable the OSPFv3 process globally, assign the OSPFv3 process a router ID, and enable the OSPFv3 process on related interfaces

**Figure 35: OSPFv3 configured parameters**

	Interface	Status	Priority	Hello Interval	Dead Interval	Cost
<input type="checkbox"/>	LAN	Disabled	1	10	40	10
<input type="checkbox"/>	WAN1	Disabled	1	10	40	10
<input type="checkbox"/>	WAN2	Disabled	1	10	40	10

**Interface:** The physical network interface on which OSPFv3 is Enabled/Disabled.

**Status:** This column displays the Enable/Disable state of OSPFv3 for a particular interface.

**Priority:** Helps to determine the OSPFv3 designated router for a network. The router with the highest priority will be more eligible to become Designated Router. Setting the value to 0, makes the router ineligible to become Designated Router. The default value is 1. Lower Value means higher priority.

**HelloInterval:** The number of seconds for HelloInterval timer value. Setting this value, Hello packet will be sent every timer value seconds on the specified interface. This value must be the same for all routers attached to a common network. The default value is 10 seconds.

**DeadInterval:** The number of seconds that a device’s hello packets must not have been seen before its neighbours declare the OSPF router down. This value must be the same for all routers attached to a common network. The default value is 40 seconds.

OSPF requires these intervals to be exactly the same between two neighbours. If any of these intervals are different, these routers will not become neighbours on a particular segment

**Cost:** The cost of sending a packet on an OSPFv3 interface.

**Figure 36: OSPFv3 configuration**

DSR-1000N	SETUP	ADVANCED	TOOLS	STATUS												
Application Rules	<div style="border: 1px solid black; padding: 5px;"> <div style="background-color: #0070C0; color: white; padding: 2px;"><b>OSPFV3 CONFIGURATION</b> <span style="float: right;">LOGOUT</span></div> <p style="text-align: center;">This page allows the user to update the configured OSPFv3 parameters</p> <p style="text-align: center;"> <input type="button" value="Save Settings"/> <input type="button" value="Don't Save Settings"/> </p> <hr/> <div style="background-color: #333; color: white; padding: 2px;"><b>Ospf3 Configuration</b></div> <table style="width: 100%; border-collapse: collapse;"> <tr> <td style="width: 30%;"><b>Ospf3 Enable:</b></td> <td><input checked="" type="checkbox"/></td> </tr> <tr> <td><b>Interface:</b></td> <td>LAN</td> </tr> <tr> <td><b>Priority:</b></td> <td><input type="text" value="1"/></td> </tr> <tr> <td><b>Hello Interval:</b></td> <td><input type="text" value="10"/></td> </tr> <tr> <td><b>Dead Interval:</b></td> <td><input type="text" value="40"/></td> </tr> <tr> <td><b>Cost:</b></td> <td><input type="text" value="10"/></td> </tr> </table> </div>				<b>Ospf3 Enable:</b>	<input checked="" type="checkbox"/>	<b>Interface:</b>	LAN	<b>Priority:</b>	<input type="text" value="1"/>	<b>Hello Interval:</b>	<input type="text" value="10"/>	<b>Dead Interval:</b>	<input type="text" value="40"/>	<b>Cost:</b>	<input type="text" value="10"/>
<b>Ospf3 Enable:</b>					<input checked="" type="checkbox"/>											
<b>Interface:</b>					LAN											
<b>Priority:</b>					<input type="text" value="1"/>											
<b>Hello Interval:</b>					<input type="text" value="10"/>											
<b>Dead Interval:</b>					<input type="text" value="40"/>											
<b>Cost:</b>					<input type="text" value="10"/>											
Website Filter																
Firewall Settin...																
Wireless Settings																
Advanced Networ...																
Routing																
Certificates																
Users																
IP/MAC Binding																
IPv6																
Radius Settings																
Captive Portal																
Switch Settings																

### 3.5.6 6to4 Tunneling

*Advanced > IPv6 > 6to4 Tunneling*

6to4 is an Internet transition mechanism for migrating from IPv4 to IPv6, a system that allows IPv6 packets to be transmitted over an IPv4 network. Select the check box to **Enable Automatic Tunneling** and allow traffic from an IPv6 LAN to be sent over a IPv4 Option to reach a remote IPv6 network.



**Figure 37: 6 to 4 tunneling**

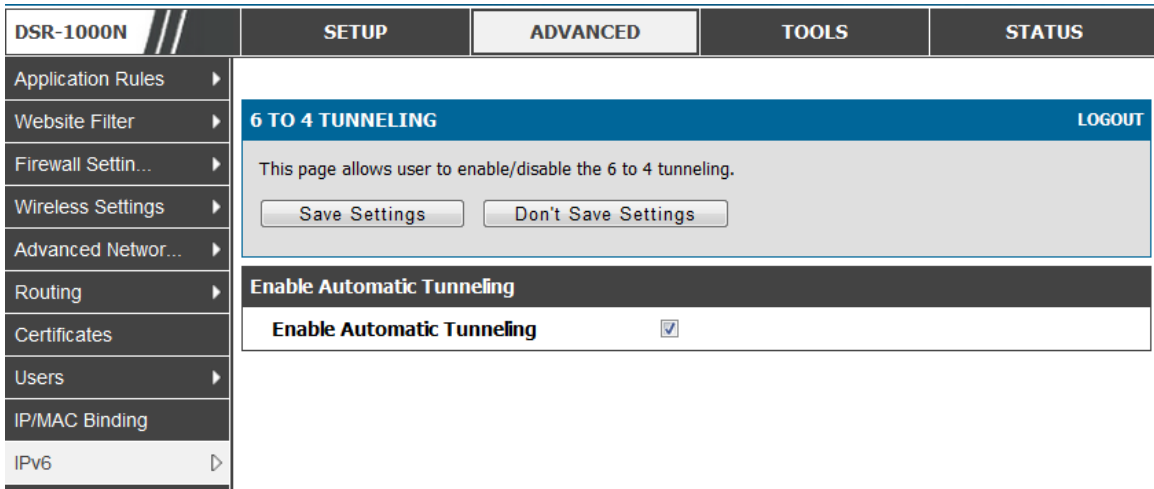

### 3.5.7 ISATAP Tunnels

*Advanced > IPv6 > 6to4 Tunneling*

ISATAP (Intra-Site Automatic Tunnel Addressing Protocol) is an IPv6 transition mechanism meant to transmit IPv6 packets between dual-stack nodes on top of an IPv4 network. ISATAP specifies an IPv6-IPv4 compatibility address format as well as a means for site border router discovery. ISATAP also specifies the operation of IPv6 over a specific link layer - that being IPv4 used as a link layer for IPv6.

**Figure 38: ISATAP Tunnels Configuration**

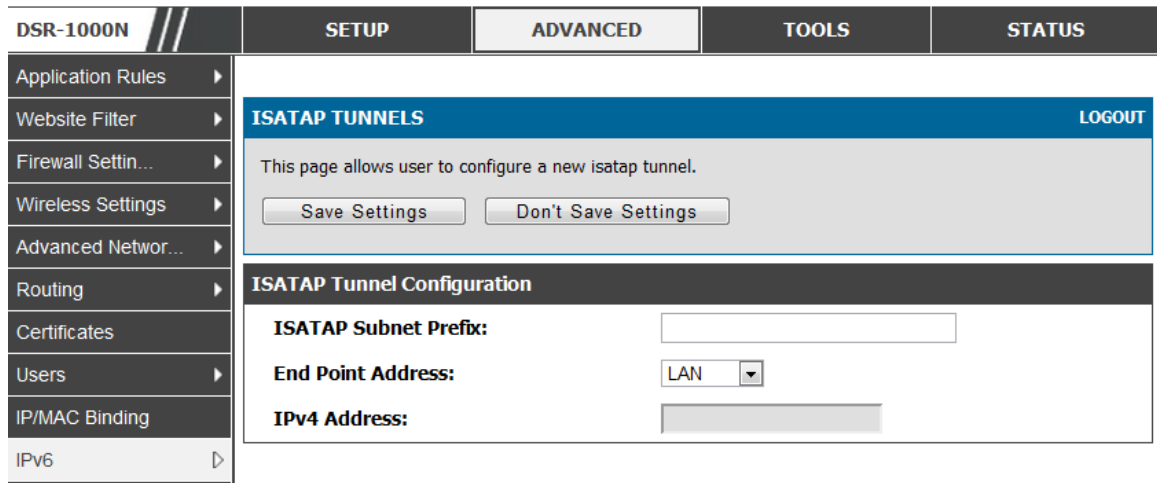

**ISATAP Subnet Prefix:** This is the 64-bit subnet prefix that is assigned to the logical ISATAP subnet for this intranet. This can be obtained from your ISP or internet registry, or derived from RFC 4193.

**End Point Address:** This is the endpoint address for the tunnel that starts with this router. The endpoint can be the LAN interface (assuming the LAN is an IPv4 network), or a specific LAN IPv4 address.

**IPv4 Address:** The end point address if not the entire LAN.

### 3.6 Configurable Port - WAN Option

This router supports one of the physical ports to be configured as a secondary WAN Ethernet port or a dedicated DMZ port. If the port is selected to be a secondary WAN interface, all configuration pages relating to WAN2 are enabled.

### 3.7 WAN 3 (3G) Configuration

This router supports one of the physical ports WAN3 to be configured for 3G internet access.

*Setup > Internet Settings > WAN3 Setup*

WAN3 configuration for the 3G USB modem is available only on WAN3 interface. There are a few key elements of WAN 3 configuration.

- **Reconnect Mode:** Select one of the following options
  - **Always On:** The connection is always on. **Username:** Enter the username required to log in to the ISP.

- On Demand: The connection is automatically ended if it is idle for a specified number of minutes. Enter the number of minutes in the Maximum Idle Time field. This feature is useful if your ISP charges you based on the amount of time that you are connected.
- Password: Enter the password required to login to the ISP.
- Dial Number: Enter the number to dial to the ISP.
- Authentication Protocol: Select one of None, PAP or CHAP Authentication Protocols to connect to the ISP.
- APN: Enter the APN (Access Point Name) provided by the ISP.

#### **Domain Name System (DNS) Servers**

- Domain name servers (DNS) convert Internet names such as www.dlink.com, to IP addresses to route traffic to the correct resources on the Internet. If you configure your router to get an IP address dynamically from the ISP, then you need to specify the DNS server source in this section.
- DNS Server Source: Choose one of the following options:
  - Get Dynamically from ISP: Choose this option if your ISP did not assign a static DNS IP address.
  - Use These DNS Servers: Choose this option if your ISP assigned a static DNS IP address for you to use. Also complete the fields that are highlighted white in this section.
  - Primary DNS Server: Enter a valid primary DNS Server IP Address.
  - Secondary DNS Server: Enter a valid secondary DNS Server IP Address.
- Configurable Port: This page allows you to assign the functionality intended for the Configurable Port. Choose from the following options:
  - WAN: If this option is selected, configure the WAN3. The WAN Mode options are now available as there are two WAN ports for the gateway.
  - DMZ: If this option is selected, you are able to configure the DMZ port on the DMZ Configuration menu.

Click **Save Settings** to save your changes.

Click **Don't Save Settings** to revert to the previous settings.

Figure 39: WAN3 configuration for 3G internet

DSR-1000N	SETUP	ADVANCED	TOOLS	STATUS
Wizard				
Internet Settings	<b>WAN3 SETUP</b> <span style="float: right;">LOGOUT</span>			
Wireless Settings	<p>This page allows you to set up your Internet connection. Ensure that you have the Internet connection information such as the IP Addresses, Account Information etc. This information is usually provided by your ISP or network administrator.</p> <p> <input type="button" value="Save Settings"/> <input type="button" value="Don't Save Settings"/> </p>			
Network Settings				
DMZ Setup				
VPN Settings				
USB Settings				
VLAN Settings				
	<p><b>Wan3 (3G Internet)</b></p> <p> <b>Reconnect Mode:</b> <input checked="" type="radio"/> Always On <input type="radio"/> On Demand         </p> <p> <b>Maximum Idle Time:</b> <input type="text" value="5"/> </p>			
	<p><b>3G Internet Connection Type</b></p> <p> <b>Username:</b> <input type="text" value="admin"/> (Optional)         </p> <p> <b>Password:</b> <input type="text" value="****"/> (Optional)         </p> <p> <b>Dial Number:</b> <input type="text" value="*99#"/> </p> <p> <b>Authentication Protocol:</b> <input type="text" value="None"/> </p> <p> <b>APN:</b> <input type="text" value="wap.isp.com"/> </p>			
	<p><b>Domain Name System (DNS) Servers</b></p> <p> <b>DNS Server Source:</b> <input type="text" value="Get Dynamically from ISP"/> </p> <p> <b>Primary DNS Server:</b> <input type="text" value="0.0.0.0"/> </p> <p> <b>Secondary DNS Server:</b> <input type="text" value="0.0.0.0"/> </p>			

 3G WAN support is available on these dual WAN products: DSR-1000 and DSR-1000N.

Cellular 3G internet access is available on WAN3 via a 3G USB modem for DSR-1000 and DSR-1000N. The cellular ISP that provides the 3G data plan will provide the authentication requirements to establish a connection. The dial Number and APN are specific to the cellular carriers. Once the connection type settings are configured and saved, navigate to the WAN status page (*Setup > Internet Settings > WAN3 Status*) and Enable the WAN3 link to establish the 3G connection.

### 3.8 WAN Port Settings

*Advanced > Advanced Network > WAN Port Setup*

The physical port settings for each WAN link can be defined here. If your ISP account defines the WAN port speed or is associated with a MAC address, this information is required by the router to ensure a smooth connection with the network.

The default MTU size supported by all ports is 1500. This is the largest packet size that can pass through the interface without fragmentation. This size can be increased, however large packets can introduce network lag and bring down the interface speed. Note that a 1500 byte size packet is the largest allowed by the Ethernet protocol at the network layer.

The port speed can be sensed by the router when Auto is selected. With this option the optimal port settings are determined by the router and network. The duplex (half or full) can be defined based on the port support, as well as one of three port speeds: 10 Mbps, 100 Mbps and 1000 Mbps (i.e. 1 Gbps). The default setting is 100 Mbps for all ports.

The default MAC address is defined during the manufacturing process for the interfaces, and can uniquely identify this router. You can customize each WAN port's MAC address as needed, either by letting the WAN port assume the current LAN host's MAC address or by entering a MAC address manually.

**Figure 40: Physical WAN port settings**

DSR-1000N	SETUP	ADVANCED	TOOLS	STATUS
Application Rules ▶	<div style="background-color: #0070C0; color: white; padding: 5px;"><b>WAN PORT SETUP</b> <span style="float: right;">LOGOUT</span></div> <p>This page allows user to configure advanced WAN options for the router.</p> <p style="text-align: center;"> <input type="button" value="Save Settings"/> <input type="button" value="Don't Save Settings"/> </p>			
Website Filter ▶				
Firewall Settings ▶				
Wireless Settings ▶				
Advanced Network ▶				
Routing ▶				
Certificates				
Users ▶				
IP/MAC Binding				
IPv6 ▶				
Radius Settings	<div style="background-color: #333; color: white; padding: 5px;"><b>WANs Ping</b></div> <p><b>Respond to Ping:</b> <input type="checkbox"/></p>			
Power Saving	<div style="background-color: #333; color: white; padding: 5px;"><b>WAN1 Port Setup</b></div> <p><b>MTU Size:</b> <input type="text" value="Default"/></p> <p><b>Custom MTU:</b> <input type="text" value="1500"/></p> <p><b>Port Speed:</b> <input type="text" value="Auto Sense"/></p>			
	<div style="background-color: #333; color: white; padding: 5px;"><b>WAN2 Port Setup</b></div> <p><b>MTU Size:</b> <input type="text" value="Default"/></p> <p><b>Custom MTU:</b> <input type="text" value="1500"/></p> <p><b>Port Speed:</b> <input type="text" value="Auto Sense"/></p>			

# Chapter 4. Wireless Access Point Setup

This router has an integrated 802.11n radio that allows you to create an access point for wireless LAN clients. The security/encryption/authentication options are grouped in a wireless Profile, and each configured profile will be available for selection in the AP configuration menu. The profile defines various parameters for the AP, including the security between the wireless client and the AP, and can be shared between multiple APs instances on the same device when needed.

 The content in this section is applicable to the DSR-500N and DSR-1000N products.

Up to four unique wireless networks can be created by configuring multiple “virtual” APs. Each such virtual AP appears as an independent AP (unique SSID) to supported clients in the environment, but is actually running on the same physical radio integrated with this router.

You will need the following information to configure your wireless network:

- Types of devices expected to access the wireless network and their supported Wi-Fi™ modes
- The router’s geographical region
- The security settings to use for securing the wireless network.

 Profiles may be thought of as a grouping of AP parameters that can then be applied to not just one but multiple AP instances (SSIDs), thus avoiding duplication if the same parameters are to be used on multiple AP instances or SSIDs.

## 4.1 Wireless Settings Wizard

*Setup > Wizard > Wireless Settings*

The Wireless Network Setup Wizard is available for users new to networking. By going through a few straightforward configuration pages you can enable a Wi-Fi™ network on your LAN and allow supported 802.11 clients to connect to the configured Access Point.

**Figure 41: Wireless Network Setup Wizards**

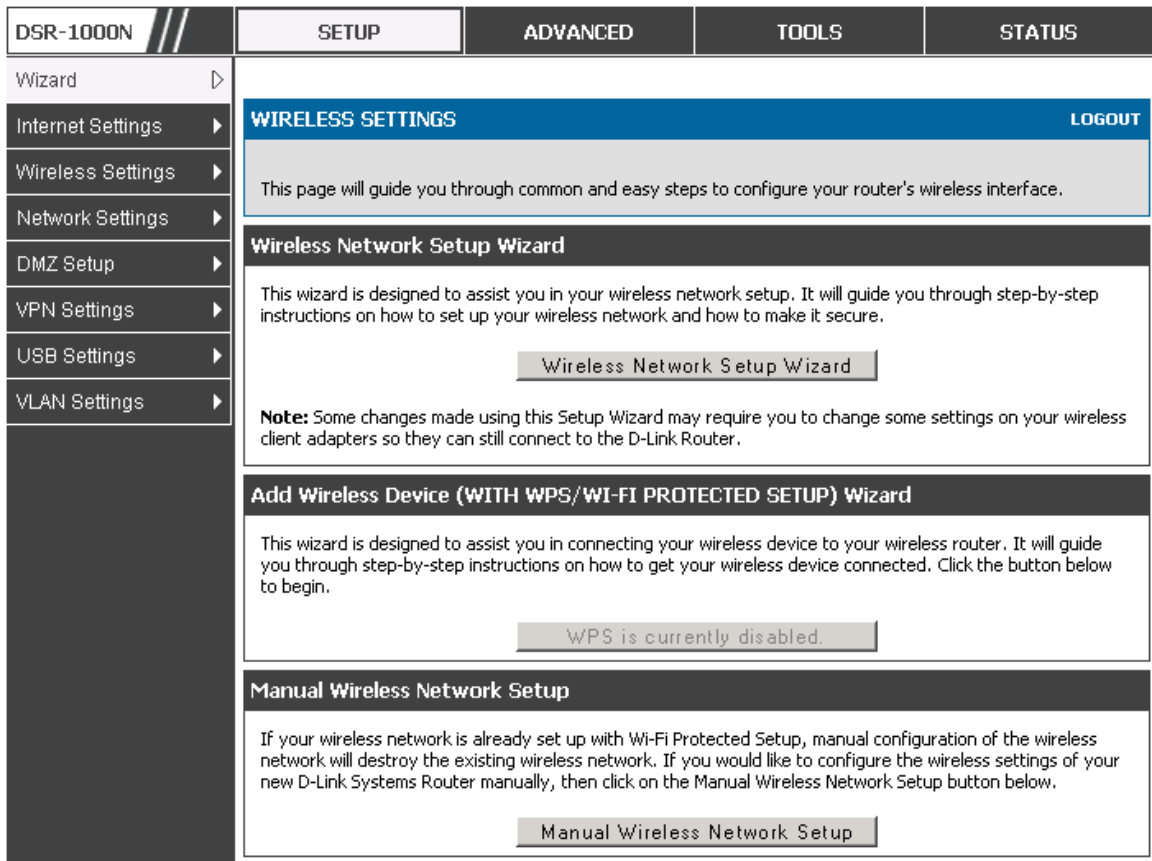

### 4.1.1 Wireless Network Setup Wizard

This wizard provides a step-by-step guide to create and secure a new access point on the router. The network name (SSID) is the AP identifier that will be detected by supported clients. The Wizard uses a TKIP+AES cipher for WPA / WPA2 security; depending on support on the client side, devices associate with this AP using either WPA or WPA2 security with the same pre-shared key.

The wizard has the option to automatically generate a network key for the AP. This key is the pre-shared key for WPA or WPA2 type security. Supported clients that have been given this PSK can associate with this AP. The default (auto-assigned) PSK is “passphrase”.

The last step in the Wizard is to click the Connect button, which confirms the settings and enables this AP to broadcast its availability in the LAN.

### 4.1.2 Add Wireless Device with WPS

With WPS enabled on your router, the selected access point allows supported WPS clients to join the network very easily. When the Auto option for connecting a

wireless device is chose, you will be presented with two common WPS setup options:

- **Personal Identification Number (PIN):** The wireless device that supports WPS may have an alphanumeric PIN, and if entered in this field the AP will establish a link to the client. Click Connect to complete setup and connect to the client.
- **Push Button Configuration (PBC):** for wireless devices that support PBC, press and hold down on this button and within 2 minutes, click the PBC connect button. The AP will detect the wireless device and establish a link to the client.

 You need to enable at least one AP with WPA/WPA2 security and also enable WPS in the *Advanced > Wireless Settings > WPS* page to use the WPS wizard.

### 4.1.3 Manual Wireless Network Setup

This button on the Wizard page will link to the *Setup > Wireless Settings > Access Points* page. The manual options allow you to create new APs or modify the parameters of APs created by the Wizard.

## 4.2 Wireless Profiles

### *Setup > Wireless Settings > Profiles*

The profile allows you to assign the security type, encryption and authentication to use when connecting the AP to a wireless client. The default mode is “open”, i.e. no security. This mode is insecure as it allows any compatible wireless clients to connect to an AP configured with this security profile.

To create a new profile, use a unique profile name to identify the combination of settings. Configure a unique SSID that will be the identifier used by the clients to communicate to the AP using this profile. By choosing to broadcast the SSID, compatible wireless clients within range of the AP can detect this profile’s availability.

The AP offers all advanced 802.11 security modes, including WEP, WPA, WPA2 and WPA+WPA2 options. The security of the Access point is configured by the Wireless Security Type section:

- **Open:** select this option to create a public “open” network to allow unauthenticated devices to access this wireless gateway.
- **WEP (Wired Equivalent Privacy):** this option requires a static (pre-shared) key to be shared between the AP and wireless client. Note that WEP does not support 802.11n data rates; is it appropriate for legacy 802.11 connections.



- WPA (Wi-Fi Protected Access): For stronger wireless security than WEP, choose this option. The encryption for WPA will use TKIP and also CCMP if required. The authentication can be a pre-shared key (PSK), Enterprise mode with RADIUS server, or both. Note that WPA does not support 802.11n data rates; is it appropriate for legacy 802.11 connections.
- WPA2: this security type uses CCMP encryption (and the option to add TKIP encryption) on either PSK (pre-shared key) or Enterprise (RADIUS Server) authentication.
- WPA + WPA2: this uses both encryption algorithms, TKIP and CCMP. WPA clients will use TKIP and WPA2 clients will use CCMP encryption algorithms.

🔗 “WPA+WPA2” is a security option that allows devices to connect to an AP using the strongest security that it supports. This mode allows legacy devices that only support WPA2 keys (such as an older wireless printer) to connect to a secure AP where all the other wireless clients are using WPA2.

**Figure 42: List of Available Profiles shows the options available to secure the wireless link**

DSR-1000N	SETUP	ADVANCED	TOOLS	STATUS																					
Wizard	<div style="background-color: #0056b3; color: white; padding: 5px;"><b>PROFILES</b></div> <div style="text-align: right; color: white; font-weight: bold; font-size: small;">LOGOUT</div> <p>A profile is a grouping of wireless settings which can be shared across multiple APs. AP specific settings are configured on the Access Point Configuration page. The profile allows for easy duplication of SSIDs, security settings, encryption methods, client authentication, etc. across APs.</p>																								
Internet Settings	<div style="background-color: #333; color: white; padding: 5px;"><b>List of Profiles</b></div> <table border="1" style="width: 100%; border-collapse: collapse;"> <thead> <tr> <th><input type="checkbox"/></th> <th>Profile Name</th> <th>SSID</th> <th>Broadcast</th> <th>Security</th> <th>Encryption</th> <th>Authentication</th> </tr> </thead> <tbody> <tr> <td><input type="checkbox"/></td> <td>default1</td> <td>admin</td> <td style="text-align: center;">✔</td> <td>WPA+WPA2</td> <td>TKIP+CCMP</td> <td>PSK</td> </tr> <tr> <td><input type="checkbox"/></td> <td>DSR-guest</td> <td>DSR_guest</td> <td style="text-align: center;">⊘</td> <td>OPEN</td> <td>NONE</td> <td>NONE</td> </tr> </tbody> </table>				<input type="checkbox"/>	Profile Name	SSID	Broadcast	Security	Encryption	Authentication	<input type="checkbox"/>	default1	admin	✔	WPA+WPA2	TKIP+CCMP	PSK	<input type="checkbox"/>	DSR-guest	DSR_guest	⊘	OPEN	NONE	NONE
<input type="checkbox"/>	Profile Name	SSID	Broadcast	Security	Encryption	Authentication																			
<input type="checkbox"/>	default1	admin	✔	WPA+WPA2	TKIP+CCMP	PSK																			
<input type="checkbox"/>	DSR-guest	DSR_guest	⊘	OPEN	NONE	NONE																			
Wireless Settings	<input type="button" value="Edit"/> <input type="button" value="Delete"/> <input type="button" value="Add"/>																								
Network Settings																									
DMZ Setup																									
VPN Settings																									
USB Settings																									
VLAN Settings																									

### 4.2.1 WEP Security

If WEP is the chosen security option, you must set a unique static key to be shared with clients that wish to access this secured wireless network. This static key can be generated from an easy-to-remember passphrase and the selected encryption length.

- Authentication: select between Open System, or Shared Key schemes

- Encryption: select the encryption key size -- 64 bit WEP or 128 bit WEP. The larger size keys provide stronger encryption, thus making the key more difficult to crack
- WEP Passphrase: enter an alphanumeric phrase and click Generate Key to generate 4 unique WEP keys with length determined by the encryption key size. Next choose one of the keys to be used for authentication. The selected key must be shared with wireless clients to connect to this device.

**Figure 43: Profile configuration to set network security**

DSR-1000N	SETUP	ADVANCED	TOOLS	STATUS
-----------	-------	----------	-------	--------

- Wizard ▶
- Internet Settings ▶
- Wireless Settings ▷
- Network Settings ▶
- DMZ Setup ▶
- VPN Settings ▶
- USB Settings
- VLAN Settings ▶

**PROFILES**
LOGOUT

The Profile Configuration page allows you to set or modify the network identifiers and wireless settings of a particular wireless profile. Profiles can be applied to more than once access point if needed.

**Profile Configuration**

<b>Profile Name:</b>	<input type="text"/>
<b>SSID:</b>	<input type="text" value="admin"/>
<b>Broadcast SSID:</b>	<input checked="" type="checkbox"/>
<b>Security:</b>	<input type="text" value="OPEN"/>
<b>Encryption:</b>	<input type="text" value="TKIP"/>
<b>Authentication:</b>	<input type="text" value="PSK"/>
<b>WPA Password:</b>	<input type="text"/>
<b>Enable Pre-Authentication:</b>	<input type="checkbox"/>

**WEP Index and Keys**

<b>Authentication:</b>	<input type="text" value="Open System"/>
<b>Encryption:</b>	<input type="text" value="64 bit WEP"/>
<b>WEP Passphrase:</b>	<input type="text"/> <input type="button" value="generate key"/>
<b>WEP Key 1:</b> <input type="radio"/>	<input type="text"/>
<b>WEP Key 2:</b> <input type="radio"/>	<input type="text"/>
<b>WEP Key 3:</b> <input type="radio"/>	<input type="text"/>
<b>WEP Key 4:</b> <input type="radio"/>	<input type="text"/>

## 4.2.2 WPA or WPA2 with PSK

A pre-shared key (PSK) is a known passphrase configured on the AP and client both and is used to authenticate the wireless client. An acceptable passphrase is between 8 to 63 characters in length.

## 4.2.3 RADIUS Authentication

### *Advanced > RADIUS Settings*

Enterprise Mode uses a RADIUS Server for WPA and/or WPA2 security. A RADIUS server must be configured and accessible by the router to authenticate

wireless client connections to an AP enabled with a profile that uses RADIUS authentication.

- The Authentication IP Address is required to identify the server. A secondary RADIUS server provides redundancy in the event that the primary server cannot be reached by the router when needed.
- Authentication Port: the port for the RADIUS server connection
- Secret: enter the shared secret that allows this router to log into the specified RADIUS server(s). This key must match the shared secret on the RADIUS Server.
- The Timeout and Retries fields are used to either move to a secondary server if the primary cannot be reached, or to give up the RADIUS authentication attempt if communication with the server is not possible.

Figure 44: RADIUS server (External Authentication) configuration

The screenshot shows the 'RADIUS SERVER' configuration page. At the top, there are navigation tabs: 'SETUP', 'ADVANCED' (selected), 'TOOLS', and 'STATUS'. A left sidebar contains a menu with items like 'Application Rules', 'Website Filter', 'Firewall Settings', 'Wireless Settings', 'Advanced Network', 'Routing', 'Certificates', 'Users', 'IP/MAC Binding', 'IPv6', 'Radius Settings' (highlighted), 'Captive Portal', 'Switch Settings', and 'Intel® AMT'. The main content area has a blue header 'RADIUS SERVER' with a 'LOGOUT' link. Below the header is a text block explaining the purpose of RADIUS servers. Two buttons, 'Save Settings' and 'Don't Save Settings', are present. The 'Radius Server Configuration' section follows, with two server entries. The 'Primary' server is configured with IP 172.16.4.5, port 1812, a secret of six asterisks, a 30-second timeout, and 3 retries. The 'Secondary' server is configured with IP 172.16.4.6, port 1812, a secret of six asterisks, a 30-second timeout, and 3 retries.

### 4.3 Creating and Using Access Points

*Setup > Wireless Settings > Access Points*

Once a profile (a group of security settings) is created, it can be assigned to an AP on the router. The AP SSID can be configured to broadcast its availability to the 802.11 environment can be used to establish a WLAN network.

The AP configuration page allows you to create a new AP and link to it one of the available profiles. This router supports multiple AP’s referred to as virtual access points (VAPs). Each virtual AP that has a unique SSIDs appears as an independent access point to clients. This valuable feature allows the router’s radio to be configured in a way to optimize security and throughput for a group of clients as required by the user. To create a VAP, click the “add” button on the *Setup > Wireless Settings > Access Points* page. After setting the AP name, the profile dropdown menu is used to select one of the configured profiles.

 The AP Name is a unique identifier used to manage the AP from the GUI, and is not the SSID that is detected by clients when the AP has broadcast enabled.

**Figure 45: Virtual AP configuration**

DSR-1000N	SETUP	ADVANCED	TOOLS	STATUS
Wizard	ACCESS POINTS <span style="float: right;">LOGOUT</span>			
Internet Settings	This page allows you to create a new AP or edit the configuration of an existing AP. The details will then be displayed in the AP table on the Wireless > Access Points page.			
Wireless Settings	<input type="button" value="Save Settings"/> <input type="button" value="Don't Save Settings"/>			
Network Settings	<b>Access Point Configuration</b>			
DMZ Setup	AP Name:	<input type="text"/>		
VPN Settings	Profile Name:	default1 <input type="button" value="v"/>		
USB Settings	Active Time:	<input type="checkbox"/>		
VLAN Settings	Start Time:	<input type="text"/> hour	<input type="text"/> minute	<input type="button" value="AM"/> <input type="button" value="v"/>
	Stop Time:	<input type="text"/> hour	<input type="text"/> minute	<input type="button" value="AM"/> <input type="button" value="v"/>
	WLAN Partition:	<input type="checkbox"/>		

A valuable power saving feature is the start and stop time control for this AP. You can conserve on the radio power by disabling the AP when it is not in use. For example on evenings and weekends if you know there are no wireless clients, the start and stop time will enable/disable the access point automatically.

Once the AP settings are configured, you must enable the AP on the radio on the *Setup > Wireless Settings > Access Points* page. The status field changes to “Enabled” if the AP is available to accept wireless clients. If the AP is configured to broadcast its SSID (a profile parameter), a green check mark indicating it is broadcasting will be shown in the List of Available Access points.

**Figure 46: List of configured access points (Virtual APs) shows one enabled access point on the radio, broadcasting its SSID**

		SETUP	ADVANCED	TOOLS	STATUS																											
DSR-1000N	<ul style="list-style-type: none"> <li>Wizard</li> <li>Internet Settings</li> <li>Wireless Settings</li> <li>Network Settings</li> <li>DMZ Setup</li> <li>VPN Settings</li> <li>USB Settings</li> <li>VLAN Settings</li> </ul>	<p><b>ACCESS POINTS</b> <span style="float: right;">LOGOUT</span></p> <p>The List of Available Access Points table lists the configured Access Points (AP) for this device. From this summary list, the status of each AP (over all radios) can be reviewed and AP parameter configuration settings can be accessed.</p> <p><b>List of Available Access Points</b></p> <table border="1"> <thead> <tr> <th><input type="checkbox"/></th> <th>Status</th> <th>Virtual AP</th> <th>SSID</th> <th>Broadcast</th> <th>Profile Name</th> <th>Active Time</th> <th>Start Time</th> <th>Stop Time</th> </tr> </thead> <tbody> <tr> <td><input type="checkbox"/></td> <td>Enabled</td> <td>ap1</td> <td>admin</td> <td style="text-align: center;">✔</td> <td>default1</td> <td>No</td> <td>-</td> <td>-</td> </tr> <tr> <td><input type="checkbox"/></td> <td>Enabled</td> <td>Open_guests</td> <td>DSR_guest</td> <td style="text-align: center;">✘</td> <td>DSR-guest</td> <td>Yes</td> <td>9:3 AM</td> <td>12:30 PM</td> </tr> </tbody> </table> <p style="text-align: center;"> <input type="button" value="Edit"/> <input type="button" value="Enable"/> <input type="button" value="Disable"/> <input type="button" value="Delete"/> <input type="button" value="Add"/> </p> <p style="text-align: center;"> <input type="button" value="MAC Filter"/> <input type="button" value="Status"/> </p>				<input type="checkbox"/>	Status	Virtual AP	SSID	Broadcast	Profile Name	Active Time	Start Time	Stop Time	<input type="checkbox"/>	Enabled	ap1	admin	✔	default1	No	-	-	<input type="checkbox"/>	Enabled	Open_guests	DSR_guest	✘	DSR-guest	Yes	9:3 AM	12:30 PM
<input type="checkbox"/>	Status	Virtual AP	SSID	Broadcast	Profile Name	Active Time	Start Time	Stop Time																								
<input type="checkbox"/>	Enabled	ap1	admin	✔	default1	No	-	-																								
<input type="checkbox"/>	Enabled	Open_guests	DSR_guest	✘	DSR-guest	Yes	9:3 AM	12:30 PM																								

The clients connected to a particular AP can be viewed by using the Status Button on the List of Available Access Points. Traffic statistics are shown for that individual AP, as compared to the summary stats for each AP on the Statistics table. Connected clients are sorted by the MAC address and indicate the security parameters used by the wireless link, as well as the time connected to this particular AP. Clicking the Details button next to the connected client will give the detailed send and receive traffic statistics for the wireless link between this AP and the client.

### 4.3.1 Primary benefits of Virtual APs:

- **Optimize throughput:** if 802.11b, 802.11 g, and 802.11n clients are expected to access the LAN via this router, creating 3 VAPs will allow you to manage or shape traffic for each group of clients. A unique SSID can be created for the network of 802.11b clients and another SSID can be assigned for the 802.11n clients. Each can have different security parameters – remember, the SSID and security of the link is determined by the profile. In this way legacy clients can access the network without bringing down the overall throughput of more capable 802.11n clients.
- **Optimize security:** you may wish to support select legacy clients that only offer WEP security while using WPA2 security for the majority of clients for the radio. By creating two VAPs configured with different SSIDs and different security parameters, both types of clients can connect to the LAN. Since WPA2 is more secure, you may want to broadcast this SSID and not

broadcast the SSID for the VAP with WEP since it is meant to be used for a few legacy devices in this scenario.

## 4.4 Tuning Radio Specific Settings

### *Setup > Wireless Settings > Radio Settings*

The Radio Settings page lets you configure the channels and power levels available for the AP's enabled on the DSR. The router has a dual band 802.11n radio, meaning either 2.4 GHz or 5 GHz frequency of operation can be selected (not concurrently though). Based on the selected operating frequency, the mode selection will let you define whether legacy connections or only 802.11n connections (or both) are accepted on configured APs.

**Figure 47: Radio card configuration options**

DSR-1000N	SETUP	ADVANCED	TOOLS	STATUS																		
Wizard	<div style="border: 1px solid black; padding: 5px;"> <div style="background-color: #0056b3; color: white; padding: 2px;"><b>RADIO SETTINGS</b></div> <div style="text-align: right; color: white; padding: 2px;"><a href="#">LOGOUT</a></div> <p style="text-align: center; margin-top: 10px;">This page allows you to configure the hardware settings for each available radio card.</p> <p style="text-align: center;"> <input type="button" value="Save Settings"/> <input type="button" value="Don't Save Settings"/> </p> <div style="background-color: #333; color: white; padding: 2px; margin-top: 10px;"><b>Radio Configuration</b></div> <table style="width: 100%; border-collapse: collapse;"> <tr> <td style="width: 60%;"><b>Operating Frequency:</b></td> <td><input type="text" value="2.4GHz"/></td> </tr> <tr> <td><b>Mode:</b></td> <td><input type="text" value="ng"/></td> </tr> <tr> <td><b>Channel Spacing:</b></td> <td><input type="text" value="20/40MHz"/></td> </tr> <tr> <td><b>Control Side Band:</b></td> <td><input type="text" value="Upper"/></td> </tr> <tr> <td><b>Current Channel:</b></td> <td>Auto</td> </tr> <tr> <td><b>Channel:</b></td> <td><input type="text" value="Auto"/></td> </tr> <tr> <td><b>Default Transmit Power:</b></td> <td><input type="text" value="31"/> (dBm)</td> </tr> <tr> <td><b>Transmit Power:</b></td> <td>15 dBm</td> </tr> <tr> <td><b>Transmission Rate:</b></td> <td><input type="text" value="Best(Automatic)"/></td> </tr> </table> </div>				<b>Operating Frequency:</b>	<input type="text" value="2.4GHz"/>	<b>Mode:</b>	<input type="text" value="ng"/>	<b>Channel Spacing:</b>	<input type="text" value="20/40MHz"/>	<b>Control Side Band:</b>	<input type="text" value="Upper"/>	<b>Current Channel:</b>	Auto	<b>Channel:</b>	<input type="text" value="Auto"/>	<b>Default Transmit Power:</b>	<input type="text" value="31"/> (dBm)	<b>Transmit Power:</b>	15 dBm	<b>Transmission Rate:</b>	<input type="text" value="Best(Automatic)"/>
<b>Operating Frequency:</b>					<input type="text" value="2.4GHz"/>																	
<b>Mode:</b>					<input type="text" value="ng"/>																	
<b>Channel Spacing:</b>					<input type="text" value="20/40MHz"/>																	
<b>Control Side Band:</b>					<input type="text" value="Upper"/>																	
<b>Current Channel:</b>					Auto																	
<b>Channel:</b>					<input type="text" value="Auto"/>																	
<b>Default Transmit Power:</b>					<input type="text" value="31"/> (dBm)																	
<b>Transmit Power:</b>					15 dBm																	
<b>Transmission Rate:</b>					<input type="text" value="Best(Automatic)"/>																	
Internet Settings																						
Wireless Settings																						
Network Settings																						
DMZ Setup																						
VPN Settings																						
USB Settings																						
VLAN Settings																						

The ratified 802.11n support on this radio requires selecting the appropriate broadcast (NA or NG etc.) mode, and then defining the channel spacing and control side band for 802.11n traffic. The default settings are appropriate for most networks. For example, changing the channel spacing to 40 MHz can improve bandwidth at the expense of supporting earlier 802.11n clients.

The available transmission channels are governed by regulatory constraints based on the region setting of the router. The maximum transmission power is similarly governed by regulatory limits; you have the option to decrease from the default maximum to reduce the signal strength of traffic out of the radio.



## 4.5 WMM

*Setup > Wireless Settings > WMM*

Wi-Fi Multimedia (WMM) provides basic Quality of service (QoS) features to IEEE 802.11 networks. WMM prioritizes traffic according to four Access Categories (AC) - voice, video, best effort, and background.

**Figure 48: Wi-Fi Multimedia**

<b>DSR-1000N</b> //	<b>SETUP</b>	<b>ADVANCED</b>	<b>TOOLS</b>	<b>STATUS</b>				
Wizard ▶	<b>WI-FI MULTIMEDIA</b> <span style="float: right;">LOGOUT</span>							
Internet Settings ▶	<input type="button" value="Save Settings"/> <input type="button" value="Don't Save Settings"/>							
Wireless Settings ▷	<b>Wi-Fi Multimedia</b>							
Network Setting... ▶	<b>Profile Name:</b> <input type="text" value="default1"/>							
DMZ Setup ▶	<b>Enable WMM:</b> <input type="checkbox"/>							
VPN Settings ▶	<b>Default Class Of Service:</b> <input type="text" value="Background"/>							
USB Settings ▶	<b>IP TOS/DiffServ Mapping</b>							
VLAN Settings ▶	<b>IP DSCP /TOS</b>	<b>Class Of Service</b>	<b>IP DSCP /TOS</b>	<b>Class Of Service</b>	<b>IP DSCP /TOS</b>	<b>Class Of Service</b>	<b>IP DSCP /TOS</b>	<b>Class Of Service</b>
	0	Default	1	Default	2	Default	3	Default
	4	Default	5	Default	6	Default	7	Default
	8	Default	9	Default	10	Default	11	Default
	12	Default	13	Default	14	Default	15	Default

**Profile Name:**

This field allows you to select the available profiles in wireless settings.

**Enable WMM:**

This field allows you to enable WMM to improve multimedia transmission.

**Default Class Of Service:**

This field allows you to select the available Access Categories (voice, video, best effort, and background).

## 4.6 Wireless distribution system (WDS)

*Setup > Wireless Settings > WDS*

Wireless distribution system is a system enabling the wireless interconnection of access points in a network. This feature is only guaranteed to work only between devices of the same type.

**Figure 49: Wireless Distribution System**

This feature is only guaranteed to work only between devices of the same type (i.e. using the same chipset/driver). For example between two DSR250N boxes, or between two DSR1000N. It should also interoperate between a DSR 1000N and DSR 500 N boxes since they are based on the same chipset/driver.

When the user enables the WDS links use the same security configuration as the default access point. The WDS links do not have true WPA/WPA2 support, as in there is no WPA key handshake performed. Instead the Session Key to be used with a WDS Peer is computed using a hashing function (similar to the one used for computing a WPA PMK). The inputs to this function are a PSK (configurable by an administrator from the WDS page) and an internal "magic" string (non-configurable).

In effect the WDS links use TKIP/AES encryption, depending on the encryption configured for the default AP. In case the default AP uses mixed encryption (TKIP + AES).The WDS link will use the AES encryption scheme.

✎ For a WDS link to function properly the Radio settings on the WDS peers have to be the same.

The WDS page would consist of two sections. The first section provides general WDS settings shared by all its WDS peers.

**WDS Enable** - This would be a check box

**WDS Encryption** - Displays the type of encryption used. It could be one of OPEN/64 bit WEP/128 bit WEP/TKIP/AES (Use the term being used throughout the box i.e. either CCMP or AES).

**WDS Passphrase** - This is required if the encryption selected is TKIP/CCMP. We would expect it to be within 8~63 ASCII characters. In the WDS configuration page this field is mandatory and has to be same on the two WDS peers, when the security is configured in TKIP/AES mode. The WDS links use this as the PSK for the connection.

**DUT's Mac Address** - This would be the mac address of this box. This should be configured in the peer's WDS configuration page to be able to establish a WDS link with this box. This field in the WDS Configuration section displays the device's mac address, which needs to be specified on the WDS peer for making a connection to this device (Similarly the WDS peers MAC address will have to be specified on this device for the WDS link to be established between the two devices).

The second section will have the list of configured WDS peers with buttons to Add/Delete Peer entries. We support up to a maximum of 4 WDS links per box.

✎ The both devices need to have same wireless settings (wireless mode, encryption, authentication method, WDS passphrase, WDS MAC address and wireless SSID) when we configure WDS features in DSR router.

The "Add WDS Peer" section allows the user to specify a WDS peer. The "WDS Peers" table displays the list of WDS peers currently configured on the device. A maximum of 4 WDS peers can be specified in any given mode.

## 4.7 Advanced Wireless Settings

*Advanced > Wireless Settings > Advanced Wireless*

Sophisticated wireless administrators can modify the 802.11 communication parameters in this page. Generally, the default settings are appropriate for most networks. Please refer to the GUI integrated help text for further details on the use of each configuration parameter.

**Figure 50: Advanced Wireless communication settings**

DSR-1000N	SETUP	ADVANCED	TOOLS	STATUS
Application Rules				
Website Filter				
Firewall Settings				
Wireless Settings	<div style="background-color: #0056b3; color: white; padding: 5px;"> <b>ADVANCED WIRELESS</b> <span style="float: right;">LOGOUT</span> </div> <p>This page is used to specify advanced configuration settings for the radio.</p> <p> <input type="button" value="Save Settings"/> <input type="button" value="Don't Save Settings"/> </p>			
Advanced Network				
Routing				
Certificates				
Users				
IP/MAC Binding				
IPv6				
Power Saving				
	<div style="background-color: #333; color: white; padding: 5px;"> <b>Advanced Wireless Configuration</b> </div> <p><b>Beacon Interval:</b> <input type="text" value="100"/> (Milliseconds)</p> <p><b>Dtim Interval:</b> <input type="text" value="2"/></p> <p><b>RTS Threshold:</b> <input type="text" value="2346"/></p> <p><b>Fragmentation Threshold:</b> <input type="text" value="2346"/></p> <p><b>Preamble Mode:</b> <input type="text" value="Long"/></p> <p><b>Protection Mode:</b> <input type="text" value="None"/></p> <p><b>Power Save Enable:</b> <input type="checkbox"/></p> <p><b>Short Retry Limit:</b> <input type="text" value="16"/></p> <p><b>Long Retry Limit:</b> <input type="text" value="16"/></p>			

## 4.8 Wi-Fi Protected Setup (WPS)

### *Advanced > Wireless Settings > WPS*

WPS is a simplified method to add supporting wireless clients to the network. WPS is only applicable for APs that employ WPA or WPA2 security. To use WPS, select the eligible VAPs from the dropdown list of APs that have been configured with this security and enable WPS status for this AP.

The WPS Current Status section outlines the security, authentication, and encryption settings of the selected AP. These are consistent with the AP’s profile. There are two setup options available for :

- **Personal Identification Number (PIN):** The wireless device that supports WPS may have an alphanumeric PIN, if so add the PIN in this field. The router will connect within 60 seconds of clicking the “Configure via PIN” button immediately below the PIN field. There is no LED indication that a client has connected.
- **Push Button Configuration (PBC):** for wireless devices that support PBC, press and hold down on this button and within 2 minutes click the PBC connect button. The AP will detect the wireless device and establish a link to the client.

✎ More than one AP can use WPS, but only one AP can be used to establish WPS links to client at any given time.

**Figure 51: WPS configuration for an AP with WPA/WPA2 profile**

DSR-1000N	SETUP	ADVANCED	TOOLS	STATUS
Application Rules ▶	<div style="border: 1px solid black; padding: 5px;"> <div style="background-color: #0056b3; color: white; padding: 2px 5px; display: flex; justify-content: space-between;"> <span>WPS</span> <span>LOGOUT</span> </div> <p style="text-align: center; margin-top: 10px;">This page allows you to define and modify the Wi-Fi Protected Setup (WPS) configuration parameters.</p> <div style="display: flex; justify-content: center; gap: 10px;"> <input type="button" value="Save Settings"/> <input type="button" value="Don't Save Settings"/> </div> </div>			
Website Filter ▶				
Firewall Settings ▶				
Wireless Settings ▾				
Advanced Network ▶				
Routing ▶				
Certificates				
Users ▶				
IP/MAC Binding				
IPv6 ▶				
Radius Settings				
Captive Portal ▶				
Switch Settings				
Intel® AMT				
	<div style="border: 1px solid black; padding: 5px;"> <div style="background-color: #333; color: white; padding: 2px 5px;"><b>WPS Configuration</b></div> <p><b>Select VAP:</b> <input type="text" value="D17-2"/></p> <p><b>WPS Status:</b> <input type="text" value="Enabled"/></p> </div>			
	<div style="border: 1px solid black; padding: 5px;"> <div style="background-color: #333; color: white; padding: 2px 5px;"><b>WPS Current Status</b></div> <p><b>Security:</b> WPA</p> <p><b>Authentication:</b></p> <p><b>Encryption:</b></p> </div>			
	<div style="border: 1px solid black; padding: 5px;"> <div style="background-color: #333; color: white; padding: 2px 5px;"><b>WPS Setup Method</b></div> <p><b>Station PIN:</b> <input type="text"/></p> <div style="display: flex; justify-content: center; gap: 10px;"> <input type="button" value="Configure via PIN"/> <input type="button" value="Configure via PBC"/> </div> <p><b>Session Status:</b></p> </div>			



# Chapter 5. Securing the Private Network

You can secure your network by creating and applying rules that your router uses to selectively block and allow inbound and outbound Internet traffic. You then specify how and to whom the rules apply. To do so, you must define the following:

- Services or traffic types (examples: web browsing, VoIP, other standard services and also custom services that you define)
- Direction for the traffic by specifying the source and destination of traffic; this is done by specifying the “From Zone” (LAN/WAN/DMZ) and “To Zone” (LAN/WAN/DMZ)
- Schedules as to when the router should apply rules
- Any Keywords (in a domain name or on a URL of a web page) that the router should allow or block
- Rules for allowing or blocking inbound and outbound Internet traffic for specified services on specified schedules
- MAC addresses of devices that should not access the internet
- Port triggers that signal the router to allow or block access to specified services as defined by port number
- Reports and alerts that you want the router to send to you

You can, for example, establish restricted-access policies based on time-of-day, web addresses, and web address keywords. You can block Internet access by applications and services on the LAN, such as chat rooms or games. You can block just certain groups of PCs on your network from being accessed by the WAN or public DMZ network.

## 5.1 Firewall Rules

### *Advanced > Firewall Settings > Firewall Rules*

Inbound (WAN to LAN/DMZ) rules restrict access to traffic entering your network, selectively allowing only specific outside users to access specific local resources. By default all access from the insecure WAN side are blocked from accessing the secure LAN, except in response to requests from the LAN or DMZ. To allow outside devices to access services on the secure LAN, you must create an inbound firewall rule for each service.

If you want to allow incoming traffic, you must make the router’s WAN port IP address known to the public. This is called “exposing your host.” How you make your address known depends on how the WAN ports are configured; for this router you

---

may use the IP address if a static address is assigned to the WAN port, or if your WAN address is dynamic a DDNS (Dynamic DNS) name can be used.

Outbound (LAN/DMZ to WAN) rules restrict access to traffic leaving your network, selectively allowing only specific local users to access specific outside resources. The default outbound rule is to allow access from the secure zone (LAN) to either the public DMZ or insecure WAN. On other hand the default outbound rule is to deny access from DMZ to insecure WAN. You can change this default behaviour in the *Firewall Settings > Default Outbound Policy* page. When the default outbound policy is allow always, you can to block hosts on the LAN from accessing internet services by creating an outbound firewall rule for each service.

Figure 52: List of Available Firewall Rules

#	Status	From Zone	To Zone	Service	Action	Source Hosts	Dest Hosts	Local Server	Internet Dest	Log
1	Enabled	LAN	WAN	ANY	ALLOW always	192.168.17.15 - 192.168.17.50	Any			Always
2	Enabled	LAN	WAN	HTTP	ALLOW always	192.168.98.10 - 192.168.98.50	192.168.1.5 - 192.168.1.254			Always
3	Enabled	LAN	WAN	ANY	ALLOW always	192.168.17.15 - 192.168.17.50	Any			Always
4	Enabled	LAN	WAN	HTTP	ALLOW always	192.168.98.10 - 192.168.98.50	192.168.1.5 - 192.168.1.254			Always

## 5.2 Defining Rule Schedules

### Tools > Schedules

Firewall rules can be enabled or disabled automatically if they are associated with a configured schedule. The schedule configuration page allows you to define days of the week and the time of day for a new schedule, and then this schedule can be selected in the firewall rule configuration page.

 All schedules will follow the time in the routers configured time zone. Refer to the section on choosing your Time Zone and configuring NTP servers for more information.



**Figure 53: List of Available Schedules to bind to a firewall rule**

Operation Succeeded

SCHEDULES		LOGOUT		
When you create a firewall rule, you can specify a schedule when the rule applies. The table lists all the Available Schedules for this device and allows several operations on the Schedules.				
List of Available Schedules				
<input type="checkbox"/>	Name	Days	Start Time	End Time
<input checked="" type="checkbox"/>	Guests	Monday, Tuesday, Wednesday, Thursday, Friday	09:00 AM	06:00 PM
<input type="checkbox"/>	Engineering	Monday, Tuesday, Wednesday	09:00 AM	06:00 PM

## 5.3 Configuring Firewall Rules

### *Advanced > Firewall Settings > Firewall Rules*

All configured firewall rules on the router are displayed in the Firewall Rules list. This list also indicates whether the rule is enabled (active) or not, and gives a summary of the From/To zone as well as the services or users that the rule affects.

To create a new firewall rules, follow the steps below:

1. View the existing rules in the List of Available Firewall Rules table.
2. To edit or add an outbound or inbound services rule, do the following:
  - To edit a rule, click the checkbox next to the rule and click Edit to reach that rule’s configuration page.
  - To add a new rule, click Add to be taken to a new rule’s configuration page. Once created, the new rule is automatically added to the original table.
3. Chose the From Zone to be the source of originating traffic: either the secure LAN, public DMZ, or insecure WAN. For an inbound rule WAN should be selected as the From Zone.
4. Choose the To Zone to be the destination of traffic covered by this rule. If the From Zone is the WAN, the to Zone can be the public DMZ or secure LAN. Similarly if the From Zone is the LAN, then the To Zone can be the public DMZ or insecure WAN.
5. Parameters that define the firewall rule include the following:

- Service: ANY means all traffic is affected by this rule. For a specific service the drop down list has common services, or you can select a custom defined service.
  - Action & Schedule: Select one of the 4 actions that this rule defines: BLOCK always, ALLOW always, BLOCK by schedule otherwise ALLOW, or ALLOW by schedule otherwise BLOCK. A schedule must be preconfigured in order for it to be available in the dropdown list to assign to this rule.
  - Source & Destination users: For each relevant category, select the users to which the rule applies:
    - Any (all users)
    - Single Address (enter an IP address)
    - Address Range (enter the appropriate IP address range)
  - Log: traffic that is filtered by this rule can be logged; this requires configuring the router's logging feature separately.
  - QoS Priority: Outbound rules (where To Zone = insecure WAN only) can have the traffic marked with a QoS priority tag. Select a priority level:
    - Normal-Service: ToS=0 (lowest QoS)
    - Minimize-Cost: ToS=1
    - Maximize-Reliability: ToS=2
    - Maximize-Throughput: ToS=4
  - Minimize-Delay: ToS=8 (highest QoS)
6. Inbound rules can use Destination NAT (DNAT) for managing traffic from the WAN. Destination NAT is available when the To Zone = DMZ or secure LAN.
- With an inbound allow rule you can enter the internal server address that is hosting the selected service.
  - You can enable port forwarding for an incoming service specific rule (From Zone = WAN) by selecting the appropriate checkbox. This will allow the selected service traffic from the internet to reach the appropriate LAN port via a port forwarding rule.
  - Translate Port Number: With port forwarding, the incoming traffic to be forwarded to the port number entered here.

- External IP address: The rule can be bound to a specific WAN interface by selecting either the primary WAN or configurable port WAN as the source IP address for incoming traffic.

 This router supports multi-NAT and so the External IP address does not necessarily have to be the WAN address. On a single WAN interface, multiple public IP addresses are supported. If your ISP assigns you more than one public IP address, one of these can be used as your primary IP address on the WAN port, and the others can be assigned to servers on the LAN or DMZ. In this way the LAN/DMZ server can be accessed from the internet by its aliased public IP address.

7. Outbound rules can use Source NAT (SNAT) in order to map (bind) all LAN/DMZ traffic matching the rule parameters to a specific WAN interface or external IP address (usually provided by your ISP).

Once the new or modified rule parameters are saved, it appears in the master list of firewall rules. To enable or disable a rule, click the checkbox next to the rule in the list of firewall rules and choose Enable or Disable.

 The router applies firewall rules in the order listed. As a general rule, you should move the strictest rules (those with the most specific services or addresses) to the top of the list. To reorder rules, click the checkbox next to a rule and click up or down.

Figure 54: Example where an outbound SNAT rule is used to map an external IP address (209.156.200.225) to a private DMZ IP address (10.30.30.30)



**Figure 55: The firewall rule configuration page allows you to define the To/From zone, service, action, schedules, and specify source/destination IP addresses as needed.**

DSR-1000N	SETUP	ADVANCED	TOOLS	STATUS
-----------	-------	----------	-------	--------

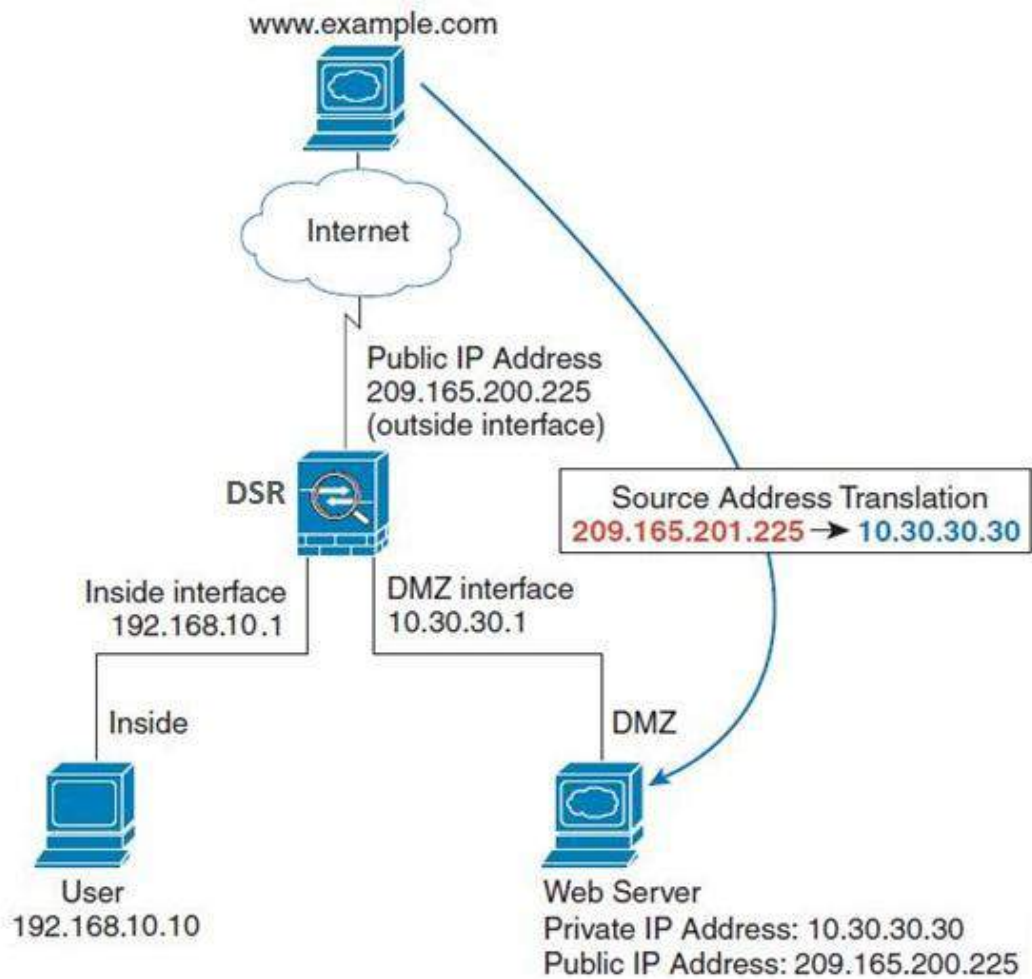
- Application Rules ▶
- Website Filter ▶
- Firewall Settings ▷
- Wireless Settings ▶
- Advanced Network ▶
- Routing ▶
- Certificates
- Users ▶
- IP/MAC Binding
- IPv6 ▶
- Power Saving

**IPV4 FIREWALL RULES**
LOGOUT

This page allows you to add a new firewall rule or edit the configuration of an existing firewall rule. The details will then be displayed in the List of Available Firewall Rules table on the Firewall Rules page.

### Firewall Rule Configuration

**From Zone:**

**To Zone:**

**Service:**

**Action:**

**Select Schedule:**

**Source Hosts:**

**From:**

**To:**

**Destination Hosts:**

**From:**

**To:**

**Log:**

**QoS Priority:**

### Source NAT Settings

**External IP Address:**

**Single IP Address:**

**WAN Interface:**

### Destination NAT Settings

**Internal IP Address:**

**Enable Port Forwarding:**

**Translate Port Number:**

**External IP Address:**

**Other IP Address:**

## 5.4 Configuring IPv6 Firewall Rules

*Advanced > Firewall Settings > IPv6 Firewall Rules*

All configured IPv6 firewall rules on the router are displayed in the Firewall Rules list. This list also indicates whether the rule is enabled (active) or not, and gives a summary of the From/To zone as well as the services or users that the rule affects.

**Figure 56: The IPv6 firewall rule configuration page allows you to define the To/From zone, service, action, schedules, and specify source/destination IP addresses as needed.**

DSR-1000N	SETUP	ADVANCED	TOOLS	STATUS
Application Rules ▶	<div style="border: 1px solid black; padding: 5px;"> <div style="background-color: #0070C0; color: white; padding: 2px;"><b>IPv6 FIREWALL RULES</b> <span style="float: right;">LOGOUT</span></div> <p style="font-size: small; margin-top: 5px;">This page allows you to add a new firewall rule or edit the configuration of an existing firewall rule. The details will then be displayed in the List of Available Firewall Rules table on the IPv6 Firewall Rules page.</p> <div style="margin-top: 5px;"> <input type="button" value="Save Settings"/> <input type="button" value="Don't Save Settings"/> </div> </div>			
Website Filter ▶				
Firewall Settin... ▷				
Wireless Settings ▶				
Advanced Networ... ▶				
Routing ▶				
Certificates				
Users ▶				
IP/MAC Binding				
IPv6 ▶				
Radius Settings	<div style="border: 1px solid black; padding: 5px;"> <div style="background-color: #333; color: white; padding: 2px;"><b>Firewall Rule Configuration</b></div> <p><b>From Zone:</b> <input type="text" value="SECURE (LAN)"/></p> <p><b>To Zone:</b> <input type="text" value="INSECURE (Dedicated WAN/Optional WAN)"/></p> <p><b>Service:</b> <input type="text" value="ANY"/></p> <p><b>Action:</b> <input type="text" value="BLOCK by schedule"/></p> <p><b>Select Schedule:</b> <input type="text"/></p> <p><b>Source Hosts:</b> <input type="text" value="Single Address"/></p> <p><b>From:</b> <input type="text" value="192.168.1.22"/></p> <p><b>To:</b> <input type="text"/></p> <p><b>Prefix Length:</b> <input type="text"/></p> <p><b>Destination Hosts:</b> <input type="text" value="Any"/></p> <p><b>From:</b> <input type="text"/></p> <p><b>To:</b> <input type="text"/></p> <p><b>Prefix Length:</b> <input type="text"/></p> <p><b>Log:</b> <input type="text" value="Always"/></p> </div>			
Captive Portal ▶				
Switch Settings				
Intel® AMT				

**Figure 57: List of Available IPv6 Firewall Rules**

DSR-1000N // SETUP ADVANCED TOOLS STATUS

Application Rules Website Filter Firewall Settings Wireless Settings Advanced Network Routing Certificates Users IP/MAC Binding IPv6 Radius Settings Captive Portal Switch Settings

Operation Succeeded

**IPv6 FIREWALL RULES** LOGOUT

A firewall is a security mechanism to selectively block or allow certain types of traffic in accordance with rules specified by network administrators. You can use this page to manage the firewall rules that control traffic to and from your IPv6 network. The List of Available Firewall Rules table includes all firewall rules for this device and allows several operations on the firewall rules.

**List of Available Firewall Rules**

<input type="checkbox"/>	Status	From Zone	To Zone	Service	Action	Source Hosts	Destination Hosts	Log
<input type="checkbox"/>	Enabled	LAN	WAN	ANY	Block Always	Any	Any	Never
<input type="checkbox"/>	Enabled	WAN	LAN	ANY	Block Always	Any	Any	Never

Edit Delete Enable Disable Add

Move To: First Move

### 5.4.1 Firewall Rule Configuration Examples

**Example 1:** Allow inbound HTTP traffic to the DMZ

**Situation:** You host a public web server on your local DMZ network. You want to allow inbound HTTP requests from any outside IP address to the IP address of your web server at any time of day.

**Solution:** Create an inbound rule as follows.

Parameter	Value
From Zone	Insecure (WAN1/WAN2/WAN3)
To Zone	Public (DMZ)
Service	HTTP
Action	ALLOW always
Send to Local Server (DNAT IP)	192.168.5.2 (web server IP address)
Destination Users	Any
Log	Never

**Example 2:** Allow videoconferencing from range of outside IP addresses

**Situation:** You want to allow incoming videoconferencing to be initiated from a restricted range of outside IP addresses (132.177.88.2 - 132.177.88.254), from a branch office.

**Solution:** Create an inbound rule as follows. In the example, CUSeeMe (the video conference service used) connections are allowed only from a specified range of external IP addresses.

Parameter	Value
From Zone	Insecure (WAN1/WAN2/WAN3)
To Zone	Secure (LAN)
Service	CU-SEEME: UDP
Action	ALLOW always
Send to Local Server (DNAT IP)	192.168.10.11
Destination Users	Address Range
From	132.177.88.2
To	134.177.88.254
Enable Port Forwarding	Yes (enabled)

**Example 3:** Multi-NAT configuration

**Situation:** You want to configure multi-NAT to support multiple public IP addresses on one WAN port interface.

**Solution:** Create an inbound rule that configures the firewall to host an additional public IP address. Associate this address with a web server on the DMZ. If you arrange with your ISP to have more than one public IP address for your use, you can use the additional public IP addresses to map to servers on your LAN. One of these public IP addresses is used as the primary IP address of the router. This address is used to provide Internet access to your LAN PCs through NAT. The other addresses are available to map to your DMZ servers.

The following addressing scheme is used to illustrate this procedure:

- WAN IP address: 10.1.0.118
- LAN IP address: 192.168.10.1; subnet 255.255.255.0
- Web server host in the DMZ, IP address: 192.168.12.222
- Access to Web server: (simulated) public IP address 10.1.0.52

Parameter	Value
From Zone	Insecure (WAN1/WAN2/WAN3)
To Zone	Public (DMZ)
Service	HTTP
Action	ALLOW always
Send to Local Server (DNAT IP)	192.168.12.222 ( web server local IP address)
Destination Users	Single Address



From	10.1.0.52
WAN Users	Any
Log	Never

**Figure 4: Block**

**Example 4:** Block traffic by schedule if generated from specific range of machines

**Use Case:** Block all HTTP traffic on the weekends if the request originates from a specific group of machines in the LAN having a known range of IP addresses, and anyone coming in through the Network from the WAN (i.e. all remote users).

**Configuration:****1. Setup a schedule:**

- To setup a schedule that affects traffic on weekends only, navigate to Security: Schedule, and name the schedule “Weekend”
- Define “weekend” to mean 12 am Saturday morning to 12 am Monday morning – all day Saturday & Sunday
- In the Scheduled days box, check that you want the schedule to be active for “specific days”. Select “Saturday” and “Sunday”
- In the scheduled time of day, select “all day” – this will apply the schedule between 12 am to 11:59 pm of the selected day.
- Click apply – now schedule “Weekend” isolates all day Saturday and Sunday from the rest of the week.

**Figure 58: Schedule configuration for the above example.**

DSR-1000N	SETUP	ADVANCED	TOOLS	STATUS
Admin	<div style="background-color: #0070c0; color: white; padding: 5px; display: flex; justify-content: space-between;"> <span>SCHEDULE CONFIGURATION</span> <span>LOGOUT</span> </div> <p style="font-size: small; margin-top: 10px;">This page allows user to configure schedules. These schedules then can be applied to firewall rules to achieve schedule based firewall.</p> <div style="display: flex; justify-content: space-around; margin-top: 10px;"> <input type="button" value="Save Settings"/> <input type="button" value="Don't Save Settings"/> </div> <div style="background-color: #333; color: white; padding: 5px; margin-top: 10px;"><b>Schedule Name</b></div> <div style="margin-top: 5px;"> <b>Name:</b> <input style="width: 100%;" type="text"/> </div> <div style="background-color: #333; color: white; padding: 5px; margin-top: 10px;"><b>Scheduled Days</b></div> <p style="font-size: small; margin-top: 5px;"><b>Do you want this schedule to be active on all days or specific days?</b> <input style="width: 50px;" type="text" value="All Days"/></p> <p><b>Monday:</b> <input type="checkbox"/></p> <p><b>Tuesday:</b> <input type="checkbox"/></p> <p><b>Wednesday:</b> <input type="checkbox"/></p> <p><b>Thursday:</b> <input type="checkbox"/></p> <p><b>Friday:</b> <input type="checkbox"/></p> <p><b>Saturday:</b> <input type="checkbox"/></p> <p><b>Sunday:</b> <input type="checkbox"/></p> <div style="background-color: #333; color: white; padding: 5px; margin-top: 10px;"><b>Scheduled Time of Day</b></div> <p style="font-size: small; margin-top: 5px;"><b>Do you want this schedule to be active all day or at specific times during the day?</b> <input style="width: 50px;" type="text" value="All Day"/></p> <p><b>Start Time:</b></p> <p><b>Hour:</b> <input style="width: 50px;" type="text"/></p> <p><b>Minute:</b> <input style="width: 50px;" type="text"/></p> <p style="text-align: right;"><input style="width: 30px;" type="text" value="AM"/></p> <p><b>End Time:</b></p> <p><b>Hour:</b> <input style="width: 50px;" type="text"/></p> <p><b>Minute:</b> <input style="width: 50px;" type="text"/></p> <p style="text-align: right;"><input style="width: 30px;" type="text" value="AM"/></p>			

2. Since we are trying to block HTTP requests, it is a service with To Zone: Insecure (WAN1/WAN2/WAN3) that is to be blocked according to schedule "Weekend".

3. Select the Action to “Block by Schedule, otherwise allow”. This will take a predefined schedule and make sure the rule is a blocking rule during the defined dates/times. All other times outside the schedule will not be affected by this firewall blocking rule
4. As we defined our schedule in schedule “Weekend”, this is available in the dropdown menu
5. We want to block the IP range assigned to the marketing group. Let’s say they have IP 192.168.10.20 to 192.168.10.30. On the Source Users dropdown, select Address Range and add this IP range as the from and To IP addresses.
6. We want to block all HTTP traffic to any services going to the insecure zone. The Destination Users dropdown should be “any”.
7. We don’t need to change default QoS priority or Logging (unless desired) – clicking apply will add this firewall rule to the list of firewall rules.
8. The last step is to enable this firewall rule. Select the rule, and click “enable” below the list to make sure the firewall rule is active

## 5.5 Security on Custom Services

### *Advanced > Firewall Settings > Custom Services*

Custom services can be defined to add to the list of services available during firewall rule configuration. While common services have known TCP/UDP/ICMP ports for traffic, many custom or uncommon applications exist in the LAN or WAN. In the custom service configuration menu you can define a range of ports and identify the traffic type (TCP/UDP/ICMP) for this service. Once defined, the new service will appear in the services list of the firewall rules configuration menu.

**Figure 59: List of user defined services.**

**Figure 60: Custom Services configuration**

Created services are available as options for firewall rule configuration.

Name: Name of the service for identification and management purposes.

Type: The layer 3 Protocol that the service uses. (TCP, UDP, BOTH, ICMP or ICMPv6)

Port Type: This fields allows to select Port Range or Multiple Ports

ICMP Type: This field is enabled when the layer 3 protocol (in the Type field) is selected as ICMP or ICMPv6. The ICMP type is a numeric value that can range between 0 and 40, while for ICMPv6 the type ranges from 1 to 255. For a list of

ICMP types, visit the following URL:<http://www.iana.org/assignments/icmp-parameters>.

**Start Port:** The first TCP, UDP or BOTH port of a range that the service uses. If the service uses only one port, then the Start Port will be the same as the Finish Port.

**Finish Port:** The last port in the range that the service uses. If the service uses only one port, then the Finish Port will be the same as the Start Port.

**Port:** The port that the service uses.

## 5.6 ALG support

### *Advanced > Firewall Settings > ALGs*

Application Level Gateways (ALGs) are security component that enhance the firewall and NAT support of this router to seamlessly support application layer protocols. In some cases enabling the ALG will allow the firewall to use dynamic ephemeral TCP/UDP ports to communicate with the known ports a particular client application (such as H.323 or RTSP) requires, without which the admin would have to open large number of ports to accomplish the same support. Because the ALG understands the protocol used by the specific application that it supports, it is a very secure and efficient way of introducing support for client applications through the router's firewall.

**Figure 61: Available ALG support on the router.**

DSR-1000N	SETUP	ADVANCED	TOOLS	STATUS																
Application Rules ▶																				
Website Filter ▶																				
Firewall Settings ▷																				
Wireless Settings ▶																				
Advanced Network ▶																				
Routing ▶																				
Certificates																				
Users ▶																				
IP/MAC Binding																				
IPv6 ▶																				
Power Saving																				
	<div style="border: 1px solid black; padding: 5px;"> <div style="background-color: #0056b3; color: white; padding: 2px;"><b>ALGS</b> <span style="float: right;">LOGOUT</span></div> <p style="font-size: small; margin-top: 5px;">Application Level Gateway allows customized NAT traversal filters to be plugged into the gateway to support address and port translation for certain application layer "control/data" protocols such as TFTP, SIP, RTSP, IPsec, PPTP etc. Each ALG provides special handling for a specific protocol or application. A number of ALGs for common applications are enabled by default.</p> <div style="display: flex; justify-content: center; gap: 10px; margin-top: 5px;"> <input type="button" value="Save Settings"/> <input type="button" value="Don't Save Settings"/> </div> </div>																			
	<div style="border: 1px solid black; padding: 5px;"> <div style="background-color: #333; color: white; padding: 2px;"><b>Enable ALGs</b></div> <table style="width: 100%; border-collapse: collapse;"> <tr> <td style="padding: 2px;"><b>PPTP:</b></td> <td style="text-align: center; padding: 2px;"><input type="checkbox"/></td> </tr> <tr> <td style="padding: 2px;"><b>IPSec:</b></td> <td style="text-align: center; padding: 2px;"><input type="checkbox"/></td> </tr> <tr> <td style="padding: 2px;"><b>RTSP:</b></td> <td style="text-align: center; padding: 2px;"><input type="checkbox"/></td> </tr> <tr> <td style="padding: 2px;"><b>SIP:</b></td> <td style="text-align: center; padding: 2px;"><input checked="" type="checkbox"/></td> </tr> <tr> <td style="padding: 2px;"><b>H.323:</b></td> <td style="text-align: center; padding: 2px;"><input checked="" type="checkbox"/></td> </tr> <tr> <td style="padding: 2px;"><b>SMTP:</b></td> <td style="text-align: center; padding: 2px;"><input checked="" type="checkbox"/></td> </tr> <tr> <td style="padding: 2px;"><b>DNS:</b></td> <td style="text-align: center; padding: 2px;"><input checked="" type="checkbox"/></td> </tr> <tr> <td style="padding: 2px;"><b>TFTP:</b></td> <td style="text-align: center; padding: 2px;"><input checked="" type="checkbox"/></td> </tr> </table> </div>				<b>PPTP:</b>	<input type="checkbox"/>	<b>IPSec:</b>	<input type="checkbox"/>	<b>RTSP:</b>	<input type="checkbox"/>	<b>SIP:</b>	<input checked="" type="checkbox"/>	<b>H.323:</b>	<input checked="" type="checkbox"/>	<b>SMTP:</b>	<input checked="" type="checkbox"/>	<b>DNS:</b>	<input checked="" type="checkbox"/>	<b>TFTP:</b>	<input checked="" type="checkbox"/>
<b>PPTP:</b>	<input type="checkbox"/>																			
<b>IPSec:</b>	<input type="checkbox"/>																			
<b>RTSP:</b>	<input type="checkbox"/>																			
<b>SIP:</b>	<input checked="" type="checkbox"/>																			
<b>H.323:</b>	<input checked="" type="checkbox"/>																			
<b>SMTP:</b>	<input checked="" type="checkbox"/>																			
<b>DNS:</b>	<input checked="" type="checkbox"/>																			
<b>TFTP:</b>	<input checked="" type="checkbox"/>																			

## 5.7 VPN Passthrough for Firewall

*Advanced > Firewall Settings > VPN Passthrough*

This router’s firewall settings can be configured to allow encrypted VPN traffic for IPsec, PPTP, and L2TP VPN tunnel connections between the LAN and internet. A specific firewall rule or service is not appropriate to introduce this passthrough support; instead the appropriate check boxes in the VPN Passthrough page must be enabled.

**Figure 62: Passthrough options for VPN tunnels**

DSR-1000N	SETUP	ADVANCED	TOOLS	STATUS
Application Rules				
Website Filter				
Firewall Settings				
Wireless Settings				
Advanced Network				
Routing				
Certificates				
Users				
IP/MAC Binding				
IPv6				
Radius Settings				
Power Saving				

VPN PASSTHROUGH		LOGOUT
This page allows user to configure VPN (IPSec, PPTP and L2TP) passthrough on the router.		
Save Settings		Don't Save Settings
VPN Passthrough		
IPSec:		<input checked="" type="checkbox"/>
PPTP:		<input checked="" type="checkbox"/>
L2TP:		<input checked="" type="checkbox"/>

## 5.8 Application Rules

### *Advanced > Application Rules > Application Rules*

Application rules are also referred to as port triggering. This feature allows devices on the LAN or DMZ to request one or more ports to be forwarded to them. Port triggering waits for an outbound request from the LAN/DMZ on one of the defined outgoing ports, and then opens an incoming port for that specified type of traffic. This can be thought of as a form of dynamic port forwarding while an application is transmitting data over the opened outgoing or incoming port(s).

Port triggering application rules are more flexible than static port forwarding that is an available option when configuring firewall rules. This is because a port triggering rule does not have to reference a specific LAN IP or IP range. As well ports are not left open when not in use, thereby providing a level of security that port forwarding does not offer.

 Port triggering is not appropriate for servers on the LAN, since there is a dependency on the LAN device making an outgoing connection before incoming ports are opened.

Some applications require that when external devices connect to them, they receive data on a specific port or range of ports in order to function properly. The router must send all incoming data for that application only on the required port or range of ports. The router has a list of common applications and games with corresponding outbound and inbound ports to open. You can also specify a port triggering rule by defining the type of traffic (TCP or UDP) and the range of incoming and outgoing ports to open when enabled.

**Figure 63: List of Available Application Rules showing 4 unique rules**

The screenshot shows the 'Application Rules' configuration page. The page has a navigation menu on the left with items like Application Rules, Website Filter, Firewall Settings, etc. The main content area has tabs for SETUP, ADVANCED, TOOLS, and STATUS. The 'ADVANCED' tab is selected, showing a table of application rules. The table has columns for Name, Enable, Protocol, Interface, Outgoing Ports (Start Port, End Port), and Incoming Ports (Start Port, End Port). Four rules are listed: XboxUDP, XboxUDP2, XboxTCP, and mIRC. Below the table are buttons for Edit, Delete, and Add.

	Name	Enable	Protocol	Interface	Outgoing Ports		Incoming Ports	
					Start Port	End Port	Start Port	End Port
<input type="checkbox"/>	XBoxUDP	Yes	UDP	LAN	88	88	88	88
<input type="checkbox"/>	XBoxUDP2	No	UDP	LAN	3074	3074	3074	3074
<input type="checkbox"/>	XBoxTCP	Yes	TCP	LAN	3074	3074	3074	3074
<input type="checkbox"/>	mIRC	Yes	TCP	LAN	2024	6000	1024	5000

The application rule status page will list any active rules, i.e. incoming ports that are being triggered based on outbound requests from a defined outgoing port.

## 5.9 Web Content Filtering

The gateway offers some standard web filtering options to allow the admin to easily create internet access policies between the secure LAN and insecure WAN. Instead of creating policies based on the type of traffic (as is the case when using firewall rules), web based content itself can be used to determine if traffic is allowed or dropped.

### 5.9.1 Content Filtering

#### *Advanced > Website Filter > Content Filtering*

Content filtering must be enabled to configure and use the subsequent features (list of Trusted Domains, filtering on Blocked Keywords, etc.). Proxy servers, which can be used to circumvent certain firewall rules and thus a potential security gap, can be blocked for all LAN devices. Java applets can be prevented from being downloaded from internet sites, and similarly the gateway can prevent ActiveX controls from being downloaded via Internet Explorer. For added security cookies, which typically contain session information, can be blocked as well for all devices on the private network.



**Figure 64: Content Filtering used to block access to proxy servers and prevent ActiveX controls from being downloaded**

DSR-1000N	SETUP	ADVANCED	TOOLS	STATUS										
Application Rules														
Website Filter	<div style="border: 1px solid black; padding: 5px;"> <div style="background-color: #0070C0; color: white; padding: 2px;"><b>CONTENT FILTERING</b> <span style="float: right;">LOGOUT</span></div> <p style="font-size: small;">This content filtering option allow the user to block access to certain Internet sites. Up to 32 key words in the site's name (web site URL) can be specified, which will block access to the site. To setup URL's, go to Approved URL's and Blocked URL's page.</p> <div style="text-align: center; margin-top: 5px;"> <input type="button" value="Save Settings"/> <input type="button" value="Don't Save Settings"/> </div> </div>													
Firewall Settings														
Wireless Settings														
Advanced Network														
Routing														
Certificates														
Users														
IP/MAC Binding														
IPv6														
Power Saving														
	<div style="border: 1px solid black; padding: 5px;"> <div style="background-color: #333; color: white; padding: 2px;"><b>Content Filtering Configuration</b></div> <table style="width: 100%; border-collapse: collapse;"> <tr> <td style="padding: 2px;"><b>Enable Content Filtering:</b></td> <td style="text-align: center; padding: 2px;"><input checked="" type="checkbox"/></td> </tr> </table> <div style="background-color: #333; color: white; padding: 2px;"><b>Web Components</b></div> <table style="width: 100%; border-collapse: collapse;"> <tr> <td style="padding: 2px;"><b>Proxy:</b></td> <td style="text-align: center; padding: 2px;"><input checked="" type="checkbox"/></td> </tr> <tr> <td style="padding: 2px;"><b>Java:</b></td> <td style="text-align: center; padding: 2px;"><input checked="" type="checkbox"/></td> </tr> <tr> <td style="padding: 2px;"><b>ActiveX:</b></td> <td style="text-align: center; padding: 2px;"><input checked="" type="checkbox"/></td> </tr> <tr> <td style="padding: 2px;"><b>Cookies:</b></td> <td style="text-align: center; padding: 2px;"><input type="checkbox"/></td> </tr> </table> </div>				<b>Enable Content Filtering:</b>	<input checked="" type="checkbox"/>	<b>Proxy:</b>	<input checked="" type="checkbox"/>	<b>Java:</b>	<input checked="" type="checkbox"/>	<b>ActiveX:</b>	<input checked="" type="checkbox"/>	<b>Cookies:</b>	<input type="checkbox"/>
<b>Enable Content Filtering:</b>	<input checked="" type="checkbox"/>													
<b>Proxy:</b>	<input checked="" type="checkbox"/>													
<b>Java:</b>	<input checked="" type="checkbox"/>													
<b>ActiveX:</b>	<input checked="" type="checkbox"/>													
<b>Cookies:</b>	<input type="checkbox"/>													

## 5.9.2 Approved URLs

### *Advanced > Website Filter > Approved URLs*

The Approved URLs is an acceptance list for all URL domain names. Domains added to this list are allowed in any form. For example, if the domain “yahoo” is added to this list then all of the following URL’s are permitted access from the LAN: www.yahoo.com, yahoo.co.uk, etc. Import/export from a text or CSV file for Approved URLs is also supported

Figure 65: Two trusted domains added to the Approved URLs List

The screenshot shows the 'ADVANCED' tab of the DSR-1000N configuration interface. A red message 'Operation succeeded' is displayed at the top. The 'Website Filter' menu item is selected, leading to the 'APPROVED URLS' page. The page contains the following elements:

- A header bar with 'APPROVED URLS' and a 'LOGOUT' link.
- A message: 'This page displays the approved URLs.'
- A section titled 'Approved URLs List' containing a table:
 

<input type="checkbox"/>	Trusted Domains
<input type="checkbox"/>	www.yahoo.com
<input type="checkbox"/>	www.dlink.com
- Buttons for 'Edit', 'Delete', and 'Add' below the table.
- An 'Import Approved URLs' section with:
  - 'Add Approved URLs from File:' label
  - 'Choose File' button (displaying 'No file chosen')
  - 'Import' button

### 5.9.3 Blocked Keywords

*Advanced > Website Filter > Blocked Keywords*

Keyword blocking allows you to block all website URL's or site content that contains the keywords in the configured list. This is lower priority than the Approved URL List; i.e. if the blocked keyword is present in a site allowed by a Trusted Domain in the Approved URL List, then access to that site will be allowed. Import/export from a text or CSV file for keyword blocking is also supported.

Figure 66: One keyword added to the block list

DSR-1000N	SETUP	ADVANCED	TOOLS	STATUS
-----------	-------	----------	-------	--------

<ul style="list-style-type: none"> <li>Application Rules</li> <li>Website Filter</li> <li>Firewall Settings</li> <li>Wireless Settings</li> <li>Advanced Network</li> <li>Routing</li> <li>Certificates</li> <li>Users</li> <li>IP/MAC Binding</li> <li>IPv6</li> <li>Radius Settings</li> <li>Captive Portal</li> <li>Switch Settings</li> <li>Intel® AMT</li> </ul>	<div style="background-color: #0070C0; color: white; padding: 2px;"><b>BLOCKED KEYWORDS</b></div> <div style="text-align: right; font-size: small; color: #0070C0;">LOGOUT</div> <p style="font-size: x-small; margin-top: 5px;">You can block access to websites by entering complete URLs or keywords. Keywords prevent access to websites that contain the specified characters in the URLs or the page contents. The table lists all the Blocked keywords and allows several operations on the keywords.</p> <table border="1" style="width: 100%; border-collapse: collapse; margin-top: 5px;"> <thead> <tr> <th colspan="2" style="background-color: #333; color: white; padding: 2px;">Blocked Keywords</th> </tr> <tr> <th style="width: 5%;"></th> <th style="width: 95%;"></th> </tr> </thead> <tbody> <tr> <td style="text-align: center;"><input type="checkbox"/></td> <td style="text-align: center;">Status</td> </tr> <tr> <td style="text-align: center;"><input type="checkbox"/></td> <td style="text-align: center;">Enabled</td> </tr> <tr> <td style="width: 5%;"></td> <td style="text-align: center;">Blocked Keyword</td> </tr> <tr> <td style="width: 5%;"></td> <td style="text-align: center;">gun</td> </tr> </tbody> </table> <div style="text-align: center; margin-top: 5px;"> <input type="button" value="Edit"/> <input type="button" value="Enable"/> <input type="button" value="Disable"/> <input type="button" value="Delete"/> <input type="button" value="Add"/> </div> <div style="background-color: #333; color: white; padding: 2px; margin-top: 10px;"><b>Import Blocked Keywords</b></div> <p style="font-size: x-small; margin-top: 5px;"><b>Add Blocked Keywords from File:</b> <input type="button" value="Choose File"/> No file chosen</p> <div style="text-align: center; margin-top: 5px;"><input type="button" value="Import"/></div>	Blocked Keywords				<input type="checkbox"/>	Status	<input type="checkbox"/>	Enabled		Blocked Keyword		gun
Blocked Keywords													
<input type="checkbox"/>	Status												
<input type="checkbox"/>	Enabled												
	Blocked Keyword												
	gun												

## 5.9.4 Export Web Filter

*Advanced > Website Filter > Export*

Export Approved URLs: Feature enables the user to export the URLs to be allowed to a csv file which can then be downloaded to the local host. The user has to click the export button to get the csv file.

Export Blocked Keywords: This feature enables the user to export the keywords to be blocked to a csv file which can then be downloaded to the local host. The user has to click the export button to get the csv file.

Figure 67: Export Approved URL list

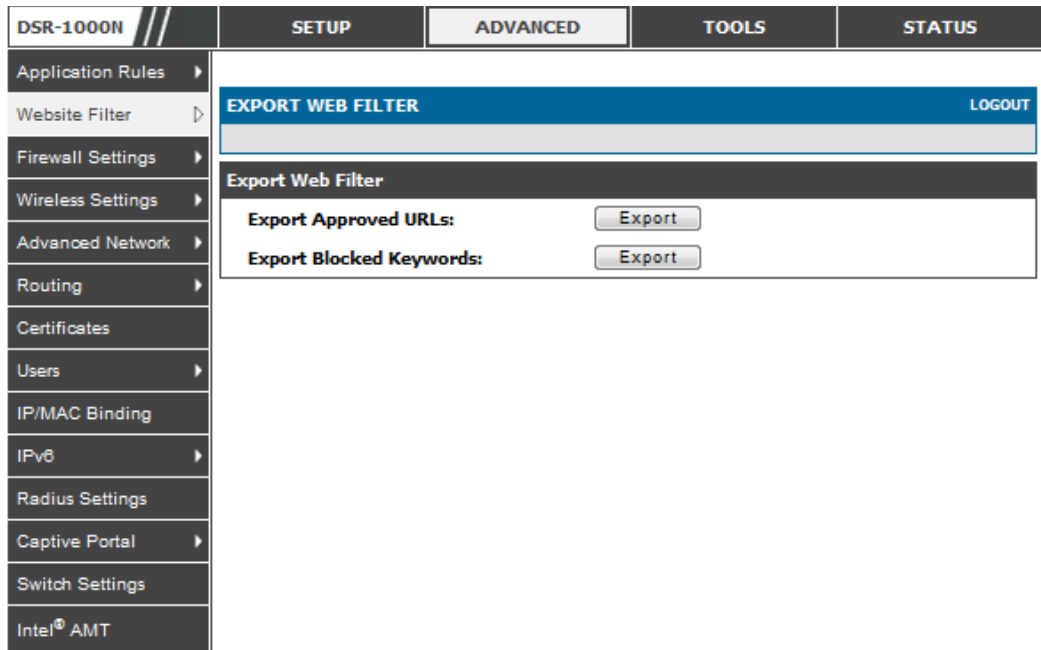

## 5.10 IP/MAC Binding

### *Advanced > IP/MAC Binding*

Another available security measure is to only allow outbound traffic (from the LAN to WAN) when the LAN node has an IP address matching the MAC address bound to it. This is IP/MAC Binding, and by enforcing the gateway to validate the source traffic’s IP address with the unique MAC Address of the configured LAN node, the administrator can ensure traffic from that IP address is not spoofed. In the event of a violation (i.e. the traffic’s source IP address doesn’t match up with the expected MAC address having the same IP address) the packets will be dropped and can be logged for diagnosis.

**Figure 68:** The following example binds a LAN host’s MAC Address to an IP address served by DSR. If there is an IP/MAC Binding violation, the violating packet will be dropped and logs will be captured

IP/MAC BINDING <span style="float: right;">LOGOUT</span>				
List of IP/MAC Binding				
<input type="checkbox"/>	Name	MAC Address	IP Address	Log Dropped Packets
<input type="checkbox"/>	test-ipmac1	AD:21:00:BC:32:25	97.0.0.8	Disabled
<input type="checkbox"/>	test-ipmac2	24:67:AB:CD:24:12	192.168.25.49	Enabled

## 5.11 Intrusion Prevention (IPS)

### *Advanced > Advanced Network > IPS*

The gateway’s Intrusion Prevention System (IPS) prevents malicious attacks from the internet from accessing the private network. Static attack signatures loaded to the DSR allow common attacks to be detected and prevented. The checks can be enabled between the WAN and DMZ or LAN, and a running counter will allow the administrator to see how many malicious intrusion attempts from the WAN have been detected and prevented.

DSR-150/150N does not support Intrusion Prevention System.

**Figure 69: Intrusion Prevention features on the router**

DSR-1000N	SETUP	ADVANCED	TOOLS	STATUS
Application Rules ▶				
Website Filter ▶				
Firewall Settings ▶				
Wireless Settings ▶				
Advanced Network ▷				
Routing ▶				
Certificates				
Users ▶				
IP/MAC Binding				
IPv6 ▶				
Radius Settings				
Power Saving				
	<b>LOGOUT</b>			
	<p>This page allows user to configure Intrusion Detection System and Intrusion Preventions system on the router.</p> <p> <input type="button" value="Save Settings"/> <input type="button" value="Don't Save Settings"/> </p>			
	<b>Intrusion Detection/Prevention Enable</b>			
	<p><b>Enable Intrusion Detection:</b> <input type="checkbox"/></p> <p><b>Enable Intrusion Prevention:</b> <input type="checkbox"/></p>			
	<b>IPS Checks Active Between</b>			
	<p><b>LAN and WAN:</b> <input type="checkbox"/></p> <p><b>DMZ and WAN:</b> <input type="checkbox"/></p>			
	<b>IPS Status</b>			
	<p><b>Number of Signatures Loaded:</b> 0</p>			

## 5.12 Protecting from Internet Attacks

### *Advanced > Advanced Network > Attack Checks*

Attacks can be malicious security breaches or unintentional network issues that render the router unusable. Attack checks allow you to manage WAN security threats such as continual ping requests and discovery via ARP scans. TCP and UDP flood attack checks can be enabled to manage extreme usage of WAN resources.

Additionally certain Denial-of-Service (DoS) attacks can be blocked. These attacks, if uninhibited, can use up processing power and bandwidth and prevent regular network services from running normally. ICMP packet flooding, SYN traffic flooding, and Echo storm thresholds can be configured to temporarily suspect traffic from the offending source.

**Figure 70: Protecting the router and LAN from internet attacks**

DSR-1000N	SETUP	ADVANCED	TOOLS	STATUS
Application Rules				
Website Filter				
Firewall Settin...				
Wireless Settings				
Advanced Networ...				
Routing				
Certificates				
Users				
IP/MAC Binding				
IPv6				
Radius Settings				
Captive Portal				
Switch Settings				
Intel® AMT				
	<div style="text-align: right;"><a href="#">LOGOUT</a></div> <p><b>ATTACK CHECKS</b></p> <p>This page allows you to specify whether or not to protect against common attacks from the LAN and WAN networks.</p> <p> <input type="button" value="Save Settings"/> <input type="button" value="Don't Save Settings"/> </p>			
	<p><b>WAN Security Checks</b></p> <p><b>Enable Stealth Mode:</b> <input checked="" type="checkbox"/></p> <p><b>Block TCP flood:</b> <input checked="" type="checkbox"/></p>			
	<p><b>LAN Security Checks</b></p> <p><b>Block UDP flood:</b> <input checked="" type="checkbox"/></p> <p><b>UDP Connection Limit:</b> <input type="text" value="25"/></p> <p><b>Allow Ping from Lan:</b> <input checked="" type="checkbox"/></p>			
	<p><b>ICSA Settings</b></p> <p><b>Block ICMP Notification:</b> <input checked="" type="checkbox"/></p> <p><b>Block Fragmented Packets:</b> <input type="checkbox"/></p> <p><b>Block Multicast Packets:</b> <input type="checkbox"/></p> <p><b>Block Spoofed IP Packets:</b> <input type="checkbox"/></p>			
	<p><b>DoS Attacks</b></p> <p><b>SYN Flood Detect Rate [max/sec]:</b> <input type="text" value="128"/></p> <p><b>Echo Storm [ping pkts./sec]:</b> <input type="text" value="15"/></p> <p><b>ICMP Flood [ICMP pkts./sec]:</b> <input type="text" value="100"/></p>			

**WAN Security Checks :**

**Enable Stealth Mode:** If Stealth Mode is enabled, the router will not respond to port scans from the WAN. This makes it less susceptible to discovery and attacks.

**Block TCP Flood:** If this option is enabled, the router will drop all invalid TCP packets and be protected from a SYN flood attack.

**LAN Security Checks :**

**Block UDP Flood:** If this option is enabled, the router will not accept more than 20 simultaneous, active UDP connections from a single computer on the LAN.

**UDP Connection Limit:** You can set the number of simultaneous active UDP connections to be accepted from a single computer on the LAN; the default is 25

**ICSA Settings :**

**Block ICMP Notification:** selecting this prevents ICMP packets from being identified as such. ICMP packets, if identified, can be captured and used in a Ping (ICMP) flood DoS attack.

Block Fragmented Packets: selecting this option drops any fragmented packets through or to the gateway

Block Multicast Packets: selecting this option drops multicast packets, which could indicate a spoof attack, through or to the gateway.

**DoS Attacks:**

SYN Flood Detect Rate (max/sec): The rate at which the SYN Flood can be detected.

Echo Storm (ping pkts/sec): The number of ping packets per second at which the router detects an Echo storm attack from the WAN and prevents further ping traffic from that external address.

ICMP Flood (ICMP pkts/sec): The number of ICMP packets per second at which the router detects an ICMP flood attack from the WAN and prevents further ICMP traffic from that external address.

 The ping on LAN interfaces is enabled in default. To disable the ping response from LAN hosts to the LAN/WAN port of the device uncheck the "Allow Ping from LAN" option.



## Chapter 6. IPsec / PPTP / L2TP VPN

A VPN provides a secure communication channel (“tunnel”) between two gateway routers or a remote PC client. The following types of tunnels can be created:

- Gateway-to-gateway VPN: to connect two or more routers to secure traffic between remote sites.
- Remote Client (client-to-gateway VPN tunnel): A remote client initiates a VPN tunnel as the IP address of the remote PC client is not known in advance. The gateway in this case acts as a responder.
- Remote client behind a NAT router: The client has a dynamic IP address and is behind a NAT Router. The remote PC client at the NAT router initiates a VPN tunnel as the IP address of the remote NAT router is not known in advance. The gateway WAN port acts as responder.
- PPTP server for LAN / WAN PPTP client connections.
- L2TP server for LAN / WAN L2TP client connections.

**Figure 71: Example of Gateway-to-Gateway IPsec VPN tunnel using two DSR routers connected to the Internet**

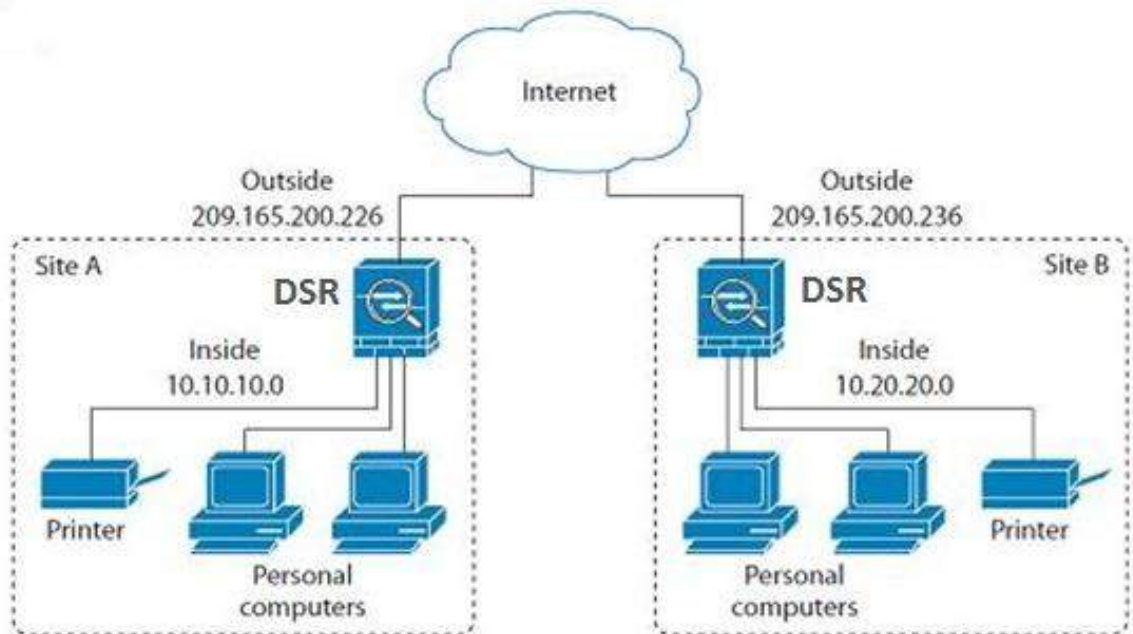
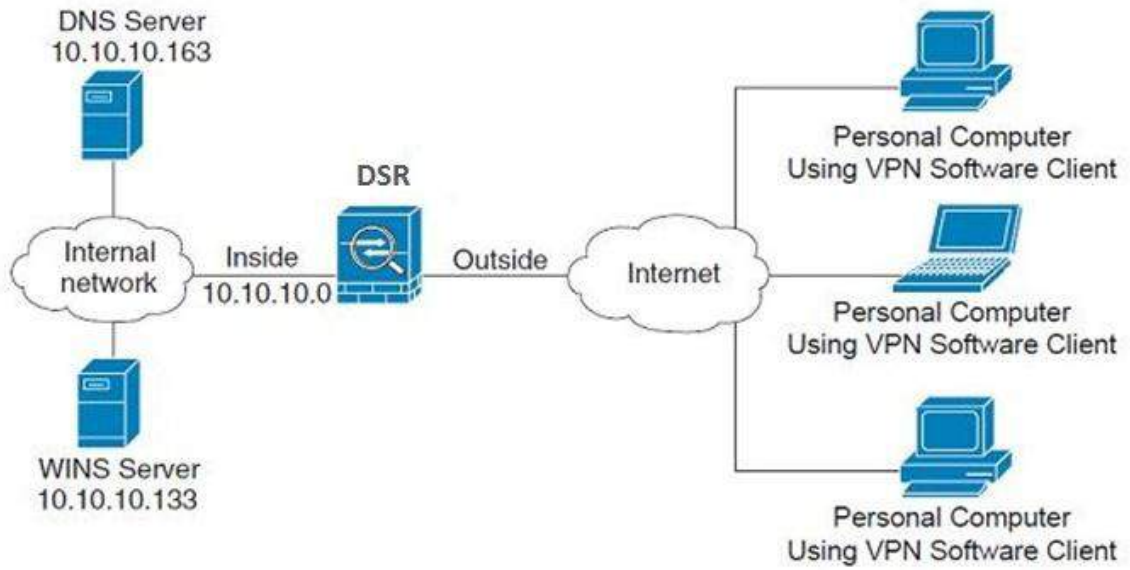

Figure 72: Example of three IPsec client connections to the internal network through the DSR IPsec gateway



## 6.1 VPN Wizard

*Setup > Wizard > VPN Wizard*

You can use the VPN wizard to quickly create both IKE and VPN policies. Once the IKE or VPN policy is created, you can modify it as required.

**Figure 73: VPN Wizard launch screen**

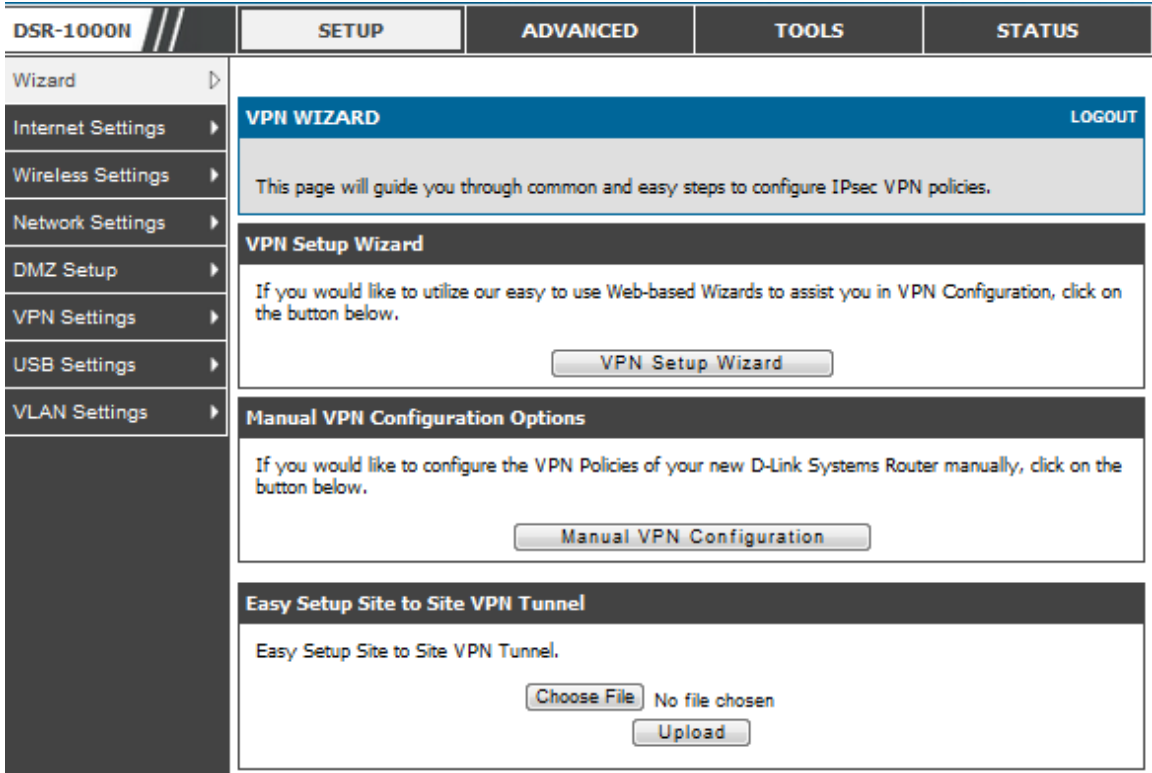

To easily establish a VPN tunnel using VPN Wizard, follow the steps below:

1. Select the VPN tunnel type to create
  - The tunnel can either be a gateway to gateway connection (site-to-site) or a tunnel to a host on the internet (remote access).
  - Set the Connection Name and pre-shared key: the connection name is used for management, and the pre-shared key will be required on the VPN client or gateway to establish the tunnel
  - Determine the local gateway for this tunnel; if there is more than 1 WAN configured the tunnel can be configured for either of the gateways.

2. Configure Remote and Local WAN address for the tunnel endpoints

- Remote Gateway Type: identify the remote endpoint of the tunnel by FQDN or static IP address
- Remote WAN IP address / FQDN: This field is enabled only if the peer you are trying to connect to is a Gateway. For VPN Clients, this IP address or Internet Name is determined when a connection request is received from a client.
- Local Gateway Type: identify this router’s endpoint of the tunnel by FQDN or static IP address
- Local WAN IP address / FQDN: This field can be left blank if you are not using a different FQDN or IP address than the one specified in the WAN port’s configuration.

3. Configure the Secure Connection Remote Accessibility fields to identify the remote network:

- Remote LAN IP address: address of the LAN behind the peer gateway
- Remote LAN Subnet Mask: the subnet mask of the LAN behind the peer

 **Note:** The IP address range used on the remote LAN must be different from the IP address range used on the local LAN.

4. Review the settings and click Connect to establish the tunnel.

The Wizard will create an Auto IPsec policy with the following default values for a VPN Client or Gateway policy (these can be accessed from a link on the Wizard page):

Parameter	Default value from Wizard
Exchange Mode	Aggressive (Client policy ) or Main (Gatew ay policy)
ID Type	FQDN
Local WAN ID	w an_local.com (only applies to Client policies)
Remote WAN ID	w an_remote.com (only applies to Client policies)
Encryption Algorithm	3DES
Authentication Algorithm	SHA-1
Authentication Method	Pre-shared Key
PFS Key-Group	DH-Group 2(1024 bit)
Life Time (Phase 1)	24 hours
Life Time (Phase 2)	8 hours

Parameter	Default value from Wizard
Exchange Mode	Aggressive (Client policy ) or Main (Gateway policy)
ID Type	FQDN
Local WAN ID	wan_local.com (only applies to Client policies)
Remote WAN ID	wan_remote.com (only applies to Client policies)
Encryption Algorithm	3DES
Authentication Algorithm	SHA-1
Authentication Method	Pre-shared Key
PFS Key-Group	DH-Group 2(1024 bit)
Life Time (Phase 1)	24 hours
NETBIOS	Enabled (only applies to Gateway policies)

 The VPN Wizard is the recommended method to set up an Auto IPsec policy. Once the Wizard creates the matching IKE and VPN policies required by the Auto policy, one can modify the required fields through the edit link. Refer to the online help for details.

Easy Setup Site to Site VPN Tunnel:

If you find it difficult to configure VPN policies through VPN wizard use easy setup site to site VPN tunnel. This will add VPN policies by importing a file containing vpn policies.

## 6.2 Configuring IPsec Policies

*Setup > VPN Settings > IPsec > IPsec Policies*

An IPsec policy is between this router and another gateway or this router and a IPsec client on a remote host. The IPsec mode can be either tunnel or transport depending on the network being traversed between the two policy endpoints.

- **Transport:** This is used for end-to-end communication between this router and the tunnel endpoint, either another IPsec gateway or an IPsec VPN client on a host. Only the data payload is encrypted and the IP header is not modified or encrypted.
- **Tunnel:** This mode is used for network-to-network IPsec tunnels where this gateway is one endpoint of the tunnel. In this mode the entire IP packet including the header is encrypted and/or authenticated.

When tunnel mode is selected, you can enable NetBIOS and DHCP over IPsec. DHCP over IPsec allows this router to serve IP leases to hosts on the remote LAN. As well in this mode you can define the single IP address, range of IPs, or subnet on both the local and remote private networks that can communicate over the tunnel.

Figure 74: IPsec policy configuration

DSR-1000N		SETUP	ADVANCED	TOOLS	STATUS
Wizard		<b>IPSEC CONFIGURATION</b> <span style="float:right">LOGOUT</span>			
Internet Settings		This page allows user to add/edit VPN (IPsec) policies which includes Auto and Manual policies.			
Wireless Settings		<input type="button" value="Save Settings"/> <input type="button" value="Don't Save Settings"/>			
Network Setting...		<b>General</b>			
DMZ Setup		<b>Policy Name:</b>	<input type="text"/>		
VPN Settings	▶	<b>Policy Type:</b>	Auto Policy ▼		
USB Settings	▶	<b>IKE Version:</b>	<input checked="" type="radio"/> IPv4 <input type="radio"/> IPv6		
VLAN Settings	▶	<b>IKE Version:</b>	<input checked="" type="radio"/> IKEv1 <input type="radio"/> IKEv2		
		<b>IPsec Mode:</b>	Tunnel Mode ▼		
		<b>Select Local Gateway:</b>	Dedicated WAN ▼		
		<b>Remote Endpoint:</b>	IP Address ▼		
			<input type="text"/>		
		<b>Enable Mode Config:</b>	<input type="checkbox"/>		
		<b>Enable NetBIOS:</b>	<input type="checkbox"/>		
		<b>Enable RollOver:</b>	<input type="checkbox"/>		
		<b>Protocol:</b>	ESP ▼		
		<b>Enable DHCP:</b>	<input type="checkbox"/>		
		<b>Local IP:</b>	Subnet ▼		
		<b>Local Start IP Address:</b>	<input type="text"/>		
		<b>Local End IP Address:</b>	<input type="text"/>		
		<b>Local Subnet Mask:</b>	<input type="text"/>		
		<b>Local Prefix Length:</b>	<input type="text"/>		
		<b>Remote IP:</b>	Subnet ▼		
		<b>Remote Start IP Address:</b>	<input type="text"/>		
		<b>Remote End IP Address:</b>	<input type="text"/>		
		<b>Remote Subnet Mask:</b>	<input type="text"/>		

Once the tunnel type and endpoints of the tunnel are defined you can determine the Phase 1 / Phase 2 negotiation to use for the tunnel. This is covered in the IPsec mode setting, as the policy can be Manual or Auto. For Auto policies, the Internet Key Exchange (IKE) protocol dynamically exchanges keys between two IPsec hosts. The Phase 1 IKE parameters are used to define the tunnel's security association details. The Phase 2 Auto policy parameters cover the security association lifetime and encryption/authentication details of the phase 2 key negotiation.

The VPN policy is one half of the IKE/VPN policy pair required to establish an Auto IPsec VPN tunnel. The IP addresses of the machine or machines on the two VPN endpoints are configured here, along with the policy parameters required to secure the tunnel

**Figure 75: IPsec policy configuration continued (Auto policy via IKE)**

Phase1(IKE SA Parameters)	
Exchange Mode:	Main
Direction / Type:	Both
<b>Nat Traversal:</b>	
On:	<input checked="" type="radio"/>
Off:	<input type="radio"/>
NAT Keep Alive Frequency (in seconds):	20
Local Identifier Type:	Local Wan IP
Local Identifier:	
Remote Identifier Type:	Remote Wan IP
Remote Identifier:	
<b>Encryption Algorithm:</b>	
Key length:	<input type="checkbox"/>
3DES:	<input type="checkbox"/>
AES-128:	<input checked="" type="checkbox"/>
AES-192:	<input type="checkbox"/>
AES-256:	<input type="checkbox"/>
BLOWFISH:	<input type="checkbox"/> <input type="text"/>
CAST128:	<input type="checkbox"/> <input type="text"/>
<b>Authentication Algorithm:</b>	
MD5:	<input type="checkbox"/>
SHA-1:	<input checked="" type="checkbox"/>
SHA2-256:	<input type="checkbox"/>
SHA2-384:	<input type="checkbox"/>
SHA2-512:	<input type="checkbox"/>
Authentication Method:	Pre-shared key
Pre-shared key:	<input type="text"/>

A Manual policy does not use IKE and instead relies on manual keying to exchange authentication parameters between the two IPsec hosts. The incoming and outgoing security parameter index (SPI) values must be mirrored on the remote tunnel

endpoint. As well the encryption and integrity algorithms and keys must match on the remote IPsec host exactly in order for the tunnel to establish successfully. Note that using Auto policies with IKE are preferred as in some IPsec implementations the SPI (security parameter index) values require conversion at each endpoint.

DSR supports VPN roll-over feature. This means that policies configured on primary WAN will rollover to the secondary WAN in case of a link failure on a primary WAN. This feature can be used only if your WAN is configured in Auto-Rollover mode.



Figure 76: IPsec policy configuration continued (Auto / Manual Phase 2)

Phase2-(Manual Policy Parameters)	
SPI-Incoming:	<input type="text" value="0x"/>
SPI-Outgoing:	<input type="text" value="0x"/>
Encryption Algorithm:	<input type="text" value="AES-128"/>
Key length:	<input type="text"/>
Key-In:	<input type="text"/>
Key-Out:	<input type="text"/>
Integrity Algorithm:	<input type="text" value="SHA-1"/>
Key-In:	<input type="text"/>
Key-Out:	<input type="text"/>
Phase2-(Auto Policy Parameters)	
SA Lifetime:	<input type="text" value="3600"/> <input type="text" value="seconds"/>
Encryption Algorithm:	
NONE:	<input type="checkbox"/>
DES:	<input type="checkbox"/>
3DES:	<input type="checkbox"/>
AES-128:	<input checked="" type="checkbox"/>
AES-192:	<input type="checkbox"/>
AES-256:	<input type="checkbox"/>
AES-CCM:	<input type="checkbox"/>
AES-GCM:	<input type="checkbox"/>
TWOFISH (128):	<input type="checkbox"/>
TWOFISH (192):	<input type="checkbox"/>
TWOFISH (256):	<input type="checkbox"/>
BLOWFISH:	<input type="checkbox"/> <input type="text"/>
CAST128:	<input type="checkbox"/> <input type="text"/>
Integrity Algorithm:	
MD5:	<input type="checkbox"/>

### 6.2.1 Extended Authentication (XAUTH)

You can also configure extended authentication (XAUTH). Rather than configure a unique VPN policy for each user, you can configure the VPN gateway router to authenticate users from a stored list of user accounts or with an external authentication server such as a RADIUS server. With a user database, user accounts created in the router are used to authenticate users.

With a configured RADIUS server, the router connects to a RADIUS server and passes to it the credentials that it receives from the VPN client. You can secure the connection between the router and the RADIUS server with the authentication protocol supported by the server (PAP or CHAP). For RADIUS – PAP, the router first checks in the user database to see if the user credentials are available; if they are not, the router connects to the RADIUS server.

## 6.2.2 Internet over IPsec tunnel

In this feature all the traffic will pass through the VPN Tunnel and from the Remote Gateway the packet will be routed to Internet. On the remote gateway side, the outgoing packet will be SNAT'ed.

## 6.3 Configuring VPN clients

Remote VPN clients must be configured with the same VPN policy parameters used in the VPN tunnel that the client wishes to use: encryption, authentication, life time, and PFS key-group. Upon establishing these authentication parameters, the VPN Client user database must also be populated with an account to give a user access to the tunnel.

 VPN client software is required to establish a VPN tunnel between the router and remote endpoint. Open source software (such as OpenVPN or Openswan) as well as Microsoft IPsec VPN software can be configured with the required IKE policy parameters to establish an IPsec VPN tunnel. Refer to the client software guide for detailed instructions on setup as well as the router's online help.

The user database contains the list of VPN user accounts that are authorized to use a given VPN tunnel. Alternatively VPN tunnel users can be authenticated using a configured Radius database. Refer to the online help to determine how to populate the user database and/or configure RADIUS authentication.

## 6.4 PPTP / L2TP Tunnels

This router supports VPN tunnels from either PPTP or L2TP ISP servers. The router acts as a broker device to allow the ISP's server to create a TCP control connection between the LAN VPN client and the VPN server.

### 6.4.1 PPTP Tunnel Support

*Setup > VPN Settings > PPTP > PPTP Client*

PPTP VPN Client can be configured on this router. Using this client we can access remote network which is local to PPTP server. Once client is enabled, the user can access *Status > Active VPNs* page and establish PPTP VPN tunnel clicking Connect. To disconnect the tunnel, click Drop.

**Figure 77: PPTP tunnel configuration – PPTP Client**

**PPTP CLIENT** LOGOUT

This page allows the user to configure PPTP VPN Client

**PPTP Client Configuration**

**Enable PPTP Client**

**PPTP Client Configuration**

**Server IP:**

**Remote Network:**

**Remote Netmask:**

**Username:**

**Password:**

**Mppe Encryption**

**Idle Time Out:**  (Seconds)

**Figure 78: PPTP VPN connection status**

Active PPTP VPN connections	
Connection Status	Action
Disconnected	<input type="button" value="Connect"/>

***Setup > VPN Settings > PPTP > PPTP Server***

A PPTP VPN can be established through this router. Once enabled a PPTP server is available on the router for LAN and WAN PPTP client users to access. Once the PPTP server is enabled, PPTP clients that are within the range of configured IP addresses of allowed clients can reach the router’s PPTP server. Once authenticated by the PPTP server (the tunnel endpoint), PPTP clients have access to the network managed by the router.

Figure 79: PPTP tunnel configuration – PPTP Server

DSR-1000N	SETUP	ADVANCED	TOOLS	STATUS
Wizard	<div style="border: 1px solid black; padding: 5px;"> <div style="background-color: #0056b3; color: white; padding: 2px;"><b>PPTP SERVER</b> <span style="float: right;">LOGOUT</span></div> <p>PPTP allows an external user to connect to your router through the internet. This section allows you to enable/disable PPTP server and define a range of IP addresses for clients connecting to your router. The connected clients can function as if they are on your LAN (they can communicate with LAN hosts, access any servers present etc.)</p> <p style="text-align: center;"> <input type="button" value="Save Settings"/> <input type="button" value="Don't Save Settings"/> </p> <div style="background-color: #333; color: white; padding: 2px;"><b>PPTP Server Configuration</b></div> <p><b>PPTP Server Mode:</b> <span style="border: 1px solid black; padding: 2px;">Disable</span></p> <div style="background-color: #333; color: white; padding: 2px;"><b>PPTP Routing Mode</b></div> <p><b>NAT:</b> <input checked="" type="radio"/></p> <p><b>Classical:</b> <input type="radio"/></p> <div style="background-color: #333; color: white; padding: 2px;"><b>Enter the range of IP addresses that is allocated to PPTP Clients</b></div> <p><b>Starting IP Address:</b> <input type="text"/></p> <p><b>Ending IP Address:</b> <input type="text"/></p> <div style="background-color: #333; color: white; padding: 2px;"><b>IPv6 Prefix</b></div> <p><b>IPv6 Prefix:</b> <input type="text"/></p> <p><b>IPv6 Prefix Length:</b> <input type="text"/></p> <div style="background-color: #333; color: white; padding: 2px;"><b>Authentication Supported</b></div> <p><b>PAP:</b> <input type="checkbox"/></p> <p><b>CHAP:</b> <input type="checkbox"/></p> <p><b>MS-CHAP:</b> <input type="checkbox"/></p> <p><b>MS-CHAPv2:</b> <input type="checkbox"/></p> <div style="background-color: #333; color: white; padding: 2px;"><b>Encryption Supported</b></div> <p><b>Mppe 40 bit:</b> <input type="checkbox"/></p> <p><b>Mppe 128 bit:</b> <input type="checkbox"/></p> <p><b>Stateful Mppe:</b> <input type="checkbox"/></p> </div>			
Internet Settings				
Wireless Settings				
Network Setting...				
DMZ Setup				
VPN Settings				
USB Settings				
VLAN Settings				

## 6.4.2 L2TP Tunnel Support

*Setup > VPN Settings > L2TP > L2TP Server*

A L2TP VPN can be established through this router. Once enabled a L2TP server is available on the router for LAN and WAN L2TP client users to access. Once the L2TP server is enabled, L2TP clients that are within the range of configured IP addresses of allowed clients can reach the router’s L2TP server. Once authenticated by the L2TP server (the tunnel endpoint), L2TP clients have access to the network managed by the router.

Figure 80: L2TP tunnel configuration – L2TP Server

DSR-1000N	SETUP	ADVANCED	TOOLS	STATUS
Wizard	<div style="border: 1px solid black; padding: 5px;"> <div style="background-color: #0070C0; color: white; padding: 2px;"><b>L2TP SERVER</b> <span style="float: right;">LOGOUT</span></div> <p>L2TP allows an external user to connect to your router through the internet, forming a VPN. This section allows you to enable/disable L2TP server and define a range of IP addresses for clients connecting to your router. The connected clients can function as if they are on your LAN (they can communicate with LAN hosts, access any servers present etc.)</p> <p style="text-align: center;"> <input type="button" value="Save Settings"/> <input type="button" value="Don't Save Settings"/> </p> </div>			
Internet Settings				
Wireless Settings				
Network Setting...				
DMZ Setup				
VPN Settings				
USB Settings				
VLAN Settings				
	<div style="border: 1px solid black; padding: 5px;"> <div style="background-color: #333; color: white; padding: 2px;"><b>L2TP Server Configuration</b></div> <p><b>L2TP Server Mode:</b> <input type="text" value="Disable"/></p> </div>			
	<div style="border: 1px solid black; padding: 5px;"> <div style="background-color: #333; color: white; padding: 2px;"><b>L2TP Routing Mode</b></div> <p><b>NAT:</b> <input checked="" type="radio"/></p> <p><b>Classical:</b> <input type="radio"/></p> </div>			
	<div style="border: 1px solid black; padding: 5px;"> <div style="background-color: #333; color: white; padding: 2px;"><b>Enter the range of IP addresses that is allocated to L2TP Clients</b></div> <p><b>Starting IP Address:</b> <input type="text"/></p> <p><b>Ending IP Address:</b> <input type="text"/></p> </div>			
	<div style="border: 1px solid black; padding: 5px;"> <div style="background-color: #333; color: white; padding: 2px;"><b>IPv6 Prefix</b></div> <p><b>IPv6 Prefix:</b> <input type="text"/></p> <p><b>IPv6 Prefix Length:</b> <input type="text"/></p> </div>			
	<div style="border: 1px solid black; padding: 5px;"> <div style="background-color: #333; color: white; padding: 2px;"><b>Authentication Supported</b></div> <p><b>PAP:</b> <input type="checkbox"/></p> <p><b>CHAP:</b> <input type="checkbox"/></p> <p><b>MS-CHAP:</b> <input type="checkbox"/></p> <p><b>MS-CHAPv2:</b> <input type="checkbox"/></p> </div>			
	<div style="border: 1px solid black; padding: 5px;"> <div style="background-color: #333; color: white; padding: 2px;"><b>L2TP Secret Key</b></div> <p><b>Enable L2TP Secret Key:</b> <input type="checkbox"/></p> <p><b>Secret Key:</b> <input type="text"/></p> </div>			
	<div style="border: 1px solid black; padding: 5px;"> <div style="background-color: #333; color: white; padding: 2px;"><b>User Time-out</b></div> <p><b>Idle Time Out:</b> <input type="text" value="0"/> (Seconds)</p> </div>			

### 6.4.3 OpenVPN Support

*Setup > VPN Settings > OpenVPN > OpenVPN Configuration*

OpenVPN allows peers to authenticate each other using a pre-shared secret key, certificates, or username/password. When used in a multiclient-server configuration, it allows the server to release an authentication certificate for every client, using

signature and Certificate authority. An Open VPN can be established through this router. Check/Uncheck this and click save settings to start/stop openvpn server.

- **Mode:** OpenVPN daemon mode. It can run in server mode, client mode or access server client mode. In access server client mode, the user has to download the auto login profile from the Openvpn Access Server and upload the same to connect.
- **Server IP:** OpenVPN server IP address to which the client connects(Applicable in client mode).
- **Vpn Network:** Address of the Virtual Network.
- **Vpn Netmask:** Netmask of the Virtual Network.
- **Port:** The port number on which openvpn server(or Access Server) runs.
- **Tunnel Protocol:** The protocol used to communicate with the remote host. Ex: Tcp, Udp. Udp is the default.
- **Encryption Algorithm:** The cipher with which the packets are encrypted. Ex: BF-CBC, AES-128,AES-192 and AES-256. BF-CBC is the default
- **Hash algorithm:** Message digest algorithm used to authenticate packets. Ex: SHA1, SHA256 and SHA512. SHA1 is the default.
- **Tunnel Type:** Select Full Tunnel to redirect all the traffic through the tunnel. Select Split Tunnel to redirect traffic to only specified resources (added from openVpnClient Routes) through the tunnel. Full Tunnel is the default.
- **Enable Client to Client communication:** Enable this to allow openvpn clients to communicate with each other in split tunnel case. Disabled by default.
- **Upload Access Server Client Configuration:** The user has to download the auto login profile and upload here to connect this router to the OpenVPN Access Server.
- **Certificates:** Select the set of certificates openvpn server uses. First Row: Set of certificates and keys the server uses. Second Row: Set of certificates and keys newly uploaded.
- **Enable Tls Authentication Key:** Enabling this adds Tls authentication which adds an additional layer of authentication. Can be checked only when the tls key is uploaded. Disabled by default.

Click Save Settings to save the settings.

Figure 81: OpenVPN configuration

VLAN Settings > **OpenVPN Server/Client Configuration**

**Enable Openvpn:**

**Mode:** Server

**Server IP:**

**Vpn Network:** 128.10.0.0

**Vpn Netmask:** 255.255.0.0

**Port:** 1194 (Default:1194)

**Tunnel Protocol:** UDP

**Encryption Algorithm:** BF-CBC

**Hash Algorithm:** SHA1

**Tunnel Type:** Full Tunnel

**Enable Client to Client Communication:**

**Upload Access Server Client Configuration**

**Upload Status:** No

**File:**  Browse...

Upload

**Certificates**

	CA Subject Name	Server/Client Cert Subject Name	Server/Client Key Uploaded	Dh Key Uploaded
<input checked="" type="checkbox"/>	C=US, ST=CA, L=SanFrancisco, O=Fort-Funston, CN=Openvpn/na ...	C=US, ST=CA, L=SanFrancisco, O=Fort-Funston, CN=serverA/na ...	yes	yes
<input type="checkbox"/>				

### 6.4.4 OpenVPN Remote Network

*Setup > VPN Settings > OpenVPN > OpenVPN Remote Network (Site-to-Site)*

This page allows the user to add/edit a remote network and netmask which allows the other OpenVPN clients to reach this network.

**Figure 82: OpenVPN Remote Network**

DSR-1000N	SETUP	ADVANCED	TOOLS	STATUS						
Wizard										
Internet Settings										
Wireless Settings										
Network Setting...										
DMZ Setup										
VPN Settings	<b>OPENVPN REMOTE NETWORK CONFIGURATION</b> <span style="float: right;">LOGOUT</span>									
USB Settings	<p>This page allows the user to add/edit a remote network and netmask which allows the other OpenVPN clients to reach this network.</p> <p style="text-align: center;"> <input type="button" value="Save Settings"/> <input type="button" value="Don't Save Settings"/> </p>									
VLAN Settings	<b>OpenVPN Remote Network Configuration</b>									
	<table style="width: 100%; border-collapse: collapse;"> <tr> <td style="width: 60%;"><b>Common Name:</b></td> <td><input type="text" value="DHQ"/></td> </tr> <tr> <td><b>Remote Network:</b></td> <td><input type="text" value="192.168.10.111"/></td> </tr> <tr> <td><b>Subnet Mask:</b></td> <td><input type="text" value="255.255.255.0"/></td> </tr> </table>				<b>Common Name:</b>	<input type="text" value="DHQ"/>	<b>Remote Network:</b>	<input type="text" value="192.168.10.111"/>	<b>Subnet Mask:</b>	<input type="text" value="255.255.255.0"/>
<b>Common Name:</b>	<input type="text" value="DHQ"/>									
<b>Remote Network:</b>	<input type="text" value="192.168.10.111"/>									
<b>Subnet Mask:</b>	<input type="text" value="255.255.255.0"/>									

**Common Name:** Common Name of the OpenVPN client certificate.

**Remote Network:** Network address of the remote resource.

**Subnet Mask:** Netmask of the remote resource.

## 6.4.5 OpenVPN Authentication

*Setup > VPN Settings > OpenVPN > OpenVPN Authentication*

This page allows the user to upload required certificates and keys.



**Figure 83: OpenVPN Authentication**

DSR-1000N	SETUP	ADVANCED	TOOLS	STATUS
Wizard				
Internet Settings	<b>OPENVPN AUTHENTICATION</b> <span style="float: right;">LOGOUT</span>			
Wireless Settings	Openvpn provides authentication using certificates. This page allows you to upload required certificates and keys which are in pem format.			
Network Setting...				
DMZ Setup	<b>Trusted Certificate (CA Certificate)</b>			
VPN Settings	<b>CA Cert Status:</b> No <b>Locate &amp; select the certificate file:</b> <input type="button" value="Choose File"/> No file chosen <input type="button" value="Upload"/>			
USB Settings	<b>Server / Client Certificate</b>			
VLAN Settings	<b>Server / Client Cert Status:</b> No <b>Locate &amp; select the certificate file:</b> <input type="button" value="Choose File"/> No file chosen <input type="button" value="Upload"/>			
	<b>Server / Client Key</b>			
	<b>Server / Client Key Status:</b> No <b>Locate &amp; select the certificate file:</b> <input type="button" value="Choose File"/> No file chosen <input type="button" value="Upload"/>			
	<b>DH Key</b>			
	<b>Dh Key Status:</b> No			

**Trusted Certificate (CA Certificate):** Browse and upload the pem formatted CA Certificate.

**Server/Client Certificate:** Browse and upload the pem formatted Server/Client Certificate.

**Server/Client Key:** Browse and upload the pem formatted Server/Client Key.

**DH Key:** Browse and upload the pem formatted Diffie Hellman Key.

**Tls Authentication Key:** Browse and upload the pem formatted Tls Authentication Key.



# Chapter 7. SSL VPN

The router provides an intrinsic SSL VPN feature as an alternate to the standard IPsec VPN. SSL VPN differs from IPsec VPN mainly by removing the requirement of a pre-installed VPN client on the remote host. Instead, users can securely login through the SSL User Portal using a standard web browser and receive access to configured network resources within the corporate LAN. The router supports multiple concurrent sessions to allow remote users to access the LAN over an encrypted link through a customizable user portal interface, and each SSL VPN user can be assigned unique privileges and network resource access levels.

The remote user can be provided different options for SSL service through this router:

- **VPN Tunnel:** The remote user's SSL enabled browser is used in place of a VPN client on the remote host to establish a secure VPN tunnel. A SSL VPN client (Active-X or Java based) is installed in the remote host to allow the client to join the corporate LAN with pre-configured access/policy privileges. At this point a virtual network interface is created on the user's host and this will be assigned an IP address and DNS server address from the router. Once established, the host machine can access allocated network resources.
- **Port Forwarding:** A web-based (ActiveX or Java) client is installed on the client machine again. Note that Port Forwarding service only supports TCP connections between the remote user and the router. The router administrator can define specific services or applications that are available to remote port forwarding users instead of access to the full LAN like the VPN tunnel.

 ActiveX clients are used when the remote user accesses the portal using the Internet Explorer browser. The Java client is used for other browsers like Mozilla Firefox, Netscape Navigator, Google Chrome, and Apple Safari.

---

Figure 84: Example of clientless SSL VPN connections to the DSR

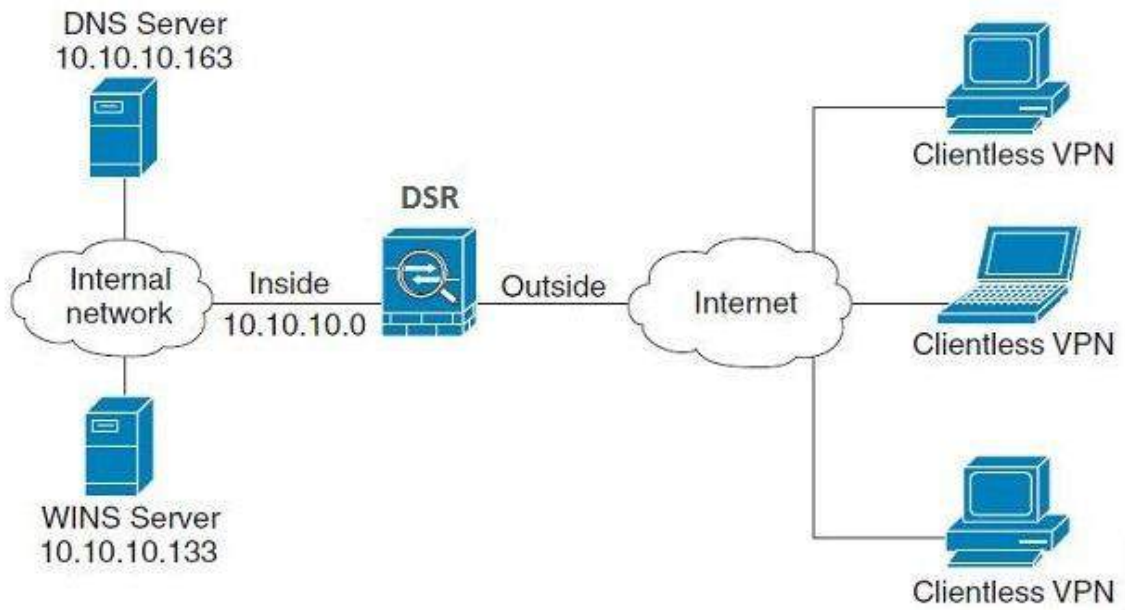

## 7.1 Groups and Users

### *Advanced > Users > Groups*

The group page allows creating, editing and deleting groups. The groups are associated to set of user types. The lists of available groups are displayed in the “List of Group” page with Group name and description of group.

- Click Add to create a group.
- Click Edit to update an existing group.
- Click Delete to clear an existing group.

**Figure 85: List of groups**

DSR-1000N	SETUP	ADVANCED	TOOLS	STATUS												
Application Rules	<div style="background-color: #0070C0; color: white; padding: 5px;"><b>GROUPS</b> <span style="float: right;">LOGOUT</span></div> <div style="border: 1px solid #ccc; padding: 5px; margin: 5px 0;">This page shows the list of added groups to the router. The user can add, delete and edit the groups also.</div> <div style="background-color: #333; color: white; padding: 5px;"><b>List of Groups</b></div> <table border="1" style="width: 100%; border-collapse: collapse;"> <thead> <tr> <th style="width: 5%;"></th> <th style="width: 45%;">Group</th> <th style="width: 50%;">Description</th> </tr> </thead> <tbody> <tr> <td><input type="checkbox"/></td> <td>ADMIN</td> <td>Admin Group</td> </tr> <tr> <td><input type="checkbox"/></td> <td>GUEST</td> <td>Guest Group</td> </tr> <tr> <td><input type="checkbox"/></td> <td>g1</td> <td>g1</td> </tr> </tbody> </table> <div style="text-align: center; margin: 10px 0;"> <input type="button" value="Edit"/> <input type="button" value="Delete"/> <input type="button" value="Add"/> </div> <div style="text-align: center; margin: 10px 0;"> <input type="button" value="Login Policies"/> <input type="button" value="Policies By Browsers"/> <input type="button" value="Policies By IP"/> </div>					Group	Description	<input type="checkbox"/>	ADMIN	Admin Group	<input type="checkbox"/>	GUEST	Guest Group	<input type="checkbox"/>	g1	g1
					Group	Description										
<input type="checkbox"/>					ADMIN	Admin Group										
<input type="checkbox"/>					GUEST	Guest Group										
<input type="checkbox"/>					g1	g1										

Group configuration page allows to create a group with a different type of users. The user types are as follows:

- **PPTP User:** These are PPTP VPN tunnel LAN users that can establish a tunnel with the PPTP server on the WAN.
- **L2TP User:** These are L2TP VPN tunnel LAN users that can establish a tunnel with the L2TP server on the WAN.
- **Xauth User:** This user’s authentication is performed by an externally configured RADIUS or other Enterprise server. It is not part of the local user database.
- **SSLVPN User:** This user has access to the SSL VPN services as determined by the group policies and authentication domain of which it is a member. The domain-determined SSL VPN portal will be displayed when logging in with this user type.

- Admin: This is the router’s super-user, and can manage the router, use SSL VPN to access network resources, and login to L2TP/PPTP servers on the WAN. There will always be one default administrator user for the GUI
- Guest User (read-only): The guest user gains read only access to the GUI to observe and review configuration settings. The guest does not have SSL VPN access.
- Captive Portal User: These captive portal users has access through the router. The access is determined based on captive portal policies.

Idle Timeout: This the log in timeout period for users of this group.

**Figure 86: User group configuration**

DSR-1000N	SETUP	ADVANCED	TOOLS	STATUS
Application Rules	<div style="border: 1px solid black; padding: 5px;"> <div style="background-color: #0070C0; color: white; padding: 2px;"><b>GROUP CONFIGURATION</b> <span style="float: right;">LOGOUT</span></div> <p style="font-size: small;">This page allows user to add a new user group. Once this group is added, a user can then add system users to it.</p> <div style="text-align: center; margin-top: 10px;"> <input type="button" value="Save Settings"/> <input type="button" value="Don't Save Settings"/> </div> </div>			
Website Filter				
Firewall Settings				
Wireless Settings				
Advanced Network				
Routing				
Certificates				
Users				
IP/MAC Binding				
IPV6				
Radius Settings	<div style="border: 1px solid black; padding: 5px;"> <div style="background-color: #333; color: white; padding: 2px;"><b>Group Configuration</b></div> <p><b>Group Name:</b> <input type="text" value="g1"/></p> <p><b>Description:</b> <input type="text" value="g1"/></p> </div>			
Captive Portal	<div style="border: 1px solid black; padding: 5px;"> <div style="background-color: #333; color: white; padding: 2px;"><b>UserType</b></div> <p><b>PPTP User:</b> <input type="checkbox"/></p> <p><b>L2TP User:</b> <input type="checkbox"/></p> <p><b>Xauth User:</b> <input type="checkbox"/></p> <p><b>SSLVPN User:</b> <input checked="" type="checkbox"/></p> <p><b>Admin:</b> <input checked="" type="checkbox"/></p> <p><b>Guest User (readonly):</b> <input type="checkbox"/></p> <p><b>Captive Portal User:</b> <input type="checkbox"/></p> <p><b>Idle Timeout:</b> <input type="text" value="10"/> (Seconds)</p> </div>			
Switch Settings				
Intel® AMT				

When SSLVPN users are selected, the SSLVPN settings are displayed with the following parameters as captured in SSLVPN Settings. As per the Authentication Type SSL VPN details are configured.

- Authentication Type: The authentication Type can be one of the following: Local User Database (default), Radius-PAP, Radius-CHAP, Radius-MSCHAP, Radius-MSCHAPv2, NT Domain, Active Directory and LDAP.
- Authentication Secret: If the domain uses RADIUS authentication then the authentication secret is required (and this has to match the secret configured on the RADIUS server).
- Workgroup: This is required is for NT domain authentication. If there are multiple workgroups, user can enter the details for up to two workgroups.
- LDAP Base DN: This is the base domain name for the LDAP authentication server. If there are multiple LDAP authentication servers, user can enter the details for up to two LDAP Base DN.

- Active Directory Domain: If the domain uses the Active Directory authentication, the Active Directory domain name is required. Users configured in the Active Directory database are given access to the SSL VPN portal with their Active Directory username and password. If there are multiple Active Directory domains, user can enter the details for up to two authentication domains.
- Timeout: The timeout period for reaching the authentication server.
- Retries: The number of retries to authenticate with the authentication server after which the DSR stops trying to reach the server.

**Figure 87: SSLVPN Settings**

SSLVPN Settings	
Portal Name:	SSLVPN
Authentication Type:	Radius-MSCHAP
Authentication Server 1:	<input type="text"/>
Authentication Server 2:	<input type="text"/> (Optional)
Authentication Server 3:	admin (Optional)
Authentication Secret 1:	*****
Authentication Secret 2:	<input type="text"/> (Optional)
LDAP attribute 1:	<input type="text"/>
LDAP attribute 2:	<input type="text"/>
LDAP attribute 3:	<input type="text"/>
LDAP attribute 4:	<input type="text"/>
Workgroup:	<input type="text"/>
Second Workgroup:	<input type="text"/> (Optional)
LDAP Base DN:	<input type="text"/>
Second LDAP Base DN:	<input type="text"/> (Optional)
Active Directory Domain:	<input type="text"/>
Second Active Directory Domain:	<input type="text"/> (Optional)
Timeout:	10 (Seconds)
Retries:	5

**Login Policies**

To set login policies for the group, select the corresponding group click “Login policies”. The following parameters are configured:

- Group Name: This is the name of the group that can have its login policy edited

- **Disable Login:** Enable to prevent the users of this group from logging into the devices management interface(s)
- **Deny Login from WAN interface:** Enable to prevent the users of this group from logging in from a WAN (wide area network) interface. In this case only login through LAN is allowed.

**Figure 88: Group login policies options**

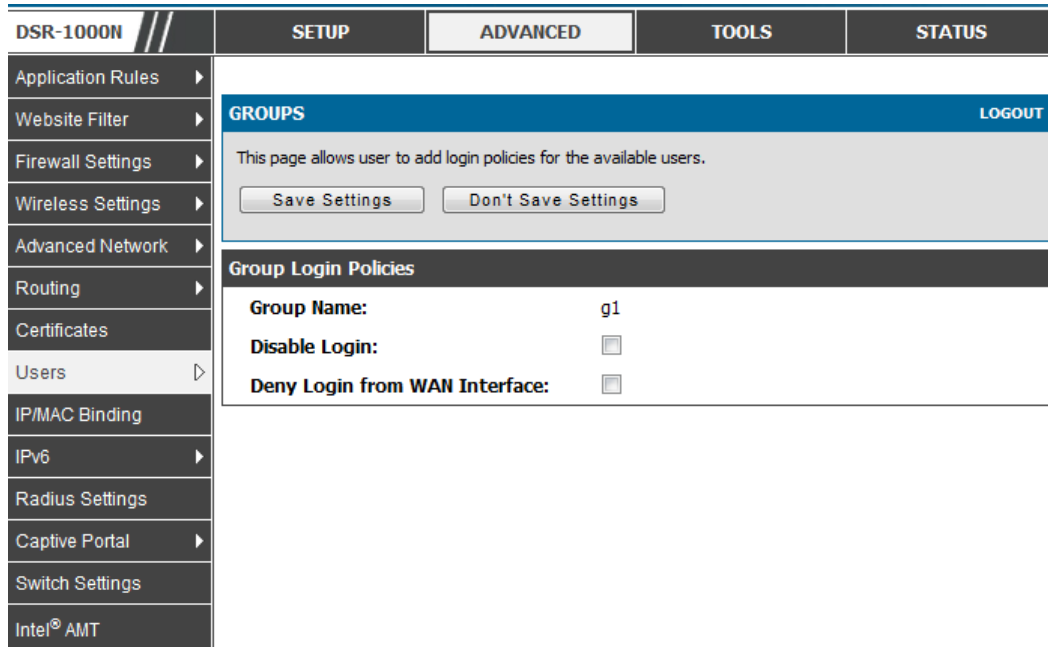

**Policy by Browsers**

To set browser policies for the group, select the corresponding group click “Policy by Browsers”. The following parameters are configured:

- **Group Name:** This is the name of the group that can have its login policy edited
- **Deny Login from Defined Browsers:** The list of defined browsers below will be used to prevent the users of this group from logging in to the routers GUI. All non-defined browsers will be allowed for login for this group.
- **Allow Login from Defined Browsers:** The list of defined browsers below will be used to allow the users of this group from logging in to the routers GUI. All non-defined browsers will be denied for login for this group.
- **Defined Browsers:** This list displays the web browsers that have been added to the Defined Browsers list, upon which group login policies can be defined. (Check Box At First Column Header): Selects all the defined browsers in the table.
- **Delete:** Deletes the selected browser(s).

You can add to the list of Defined Browsers by selecting a client browser from the drop down menu and clicking Add. This browser will then appear in the above list of Defined Browsers.

- Click Save Settings to save your changes.



**Figure 89: Browser policies options**

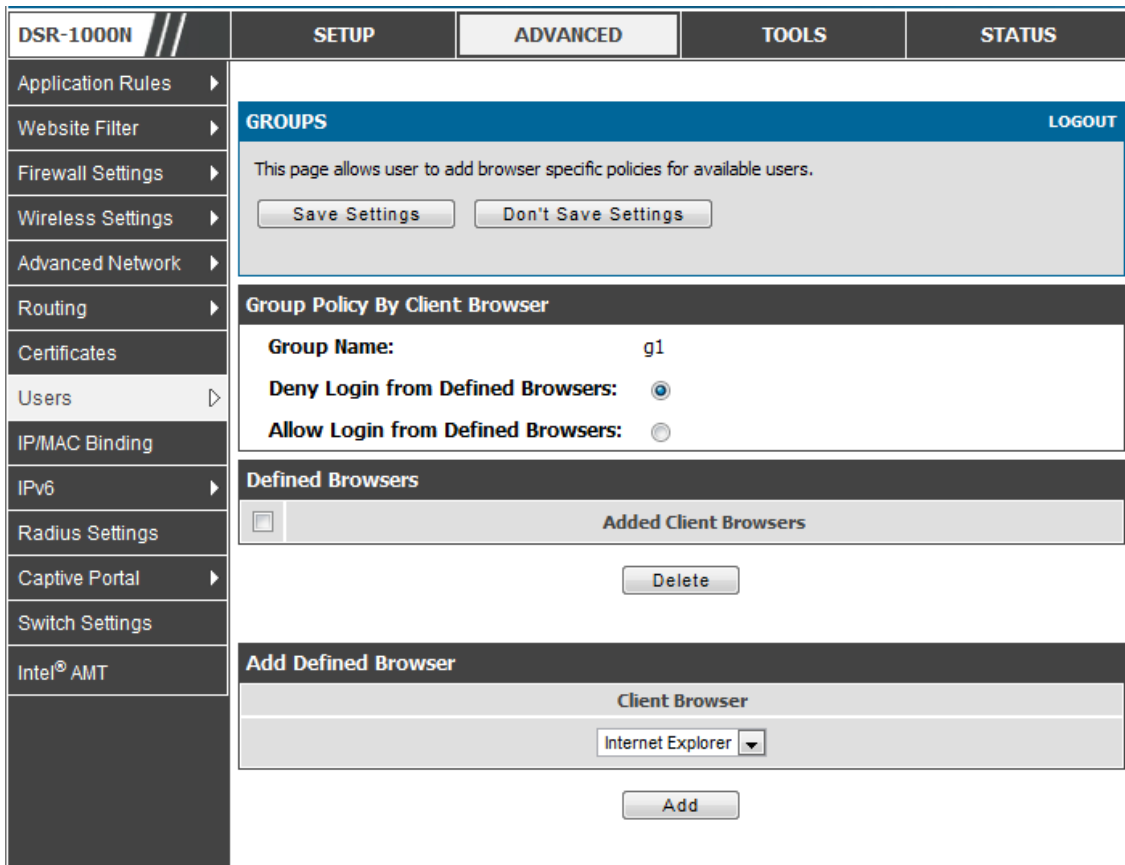

**Policy by IP**

To set policies by IP for the group, select the corresponding group click “Policy by IP”. The following parameters are configured:

- **Group Name:** This is the name of the group that can have its login policy edited
- **Deny Login from Defined Browsers:** The list of defined browsers below will be used to prevent the users of this group from logging in to the routers GUI. All non-defined browsers will be allowed for login for this group.
- **Allow Login from Defined Browsers:** The list of defined browsers below will be used to allow the users of this group from logging in to the routers GUI. All non-defined browsers will be denied for login for this group.
- **Defined Browsers:** This list displays the web browsers that have been added to the Defined Browsers list, upon which group login policies can be defined. (Check Box At First Column Header): Selects all the defined browsers in the table.
- **Delete:** Deletes the selected browser(s).

You can add to the list of Defined Browsers by selecting a client browser from the drop down menu and clicking Add. This browser will then appear in the above list of Defined Browsers.

- Click Save Settings to save your changes.

**Figure 90: IP policies options**

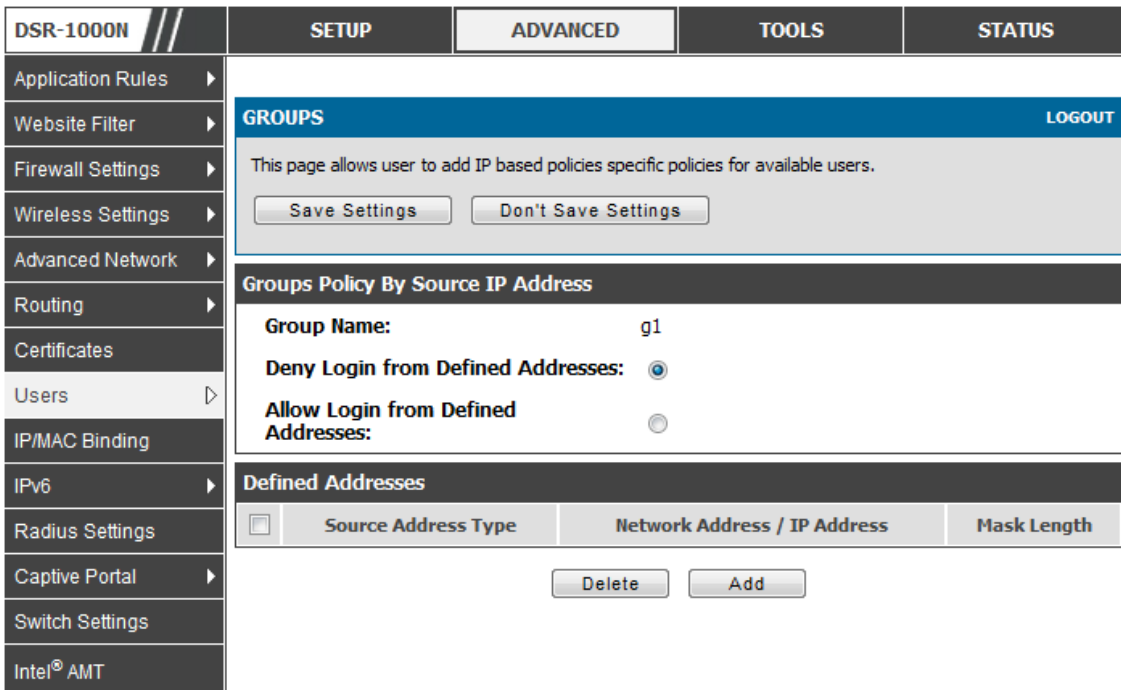

 Login Policies, Policy by Browsers, Policy by IP are applicable SSL VPN user only.

***Advanced > Users > Users***

The users page allows adding, editing and deleting existing groups. The user are associated to configured groups. The lists of available users are displayed in the “List of Users” page with User name, associated group and Login status .

- Click Add to create a user.
- Click Edit to update an existing user.
- Click Delete to clear an existing user

**Figure 91: Available Users with login status and associated Group**

DSR-1000N	SETUP	ADVANCED	TOOLS	STATUS
Application Rules				
Website Filter	<b>USERS</b> <span style="float: right;">LOGOUT</span>			
Firewall Settings	This page shows a list of available users in the system. A user can add, delete and edit the users also. This page can also be used for setting policies on users.			
Wireless Settings				
Advanced Network	<b>List of Users</b>			
Routing	<input type="checkbox"/>	<b>User Name</b>	<b>Group</b>	<b>Login Status</b>
Certificates	<input type="checkbox"/>	admin	ADMIN	Enabled (LAN and WAN)
Users	<input type="checkbox"/>	guest	GUEST	Disabled
IP/MAC Binding	<input type="checkbox"/>	u1	g1	Enabled (LAN and WAN)
IPv6	<input type="checkbox"/>	u2	g1	Enabled (LAN and WAN)
Radius Settings	<input type="checkbox"/>	u3	g1	Enabled (LAN and WAN)
Captive Portal	<input type="checkbox"/>	u4	g1	Enabled (LAN and WAN)
Switch Settings	<input type="checkbox"/>	u5	g1	Enabled (LAN and WAN)
Intel® AMT	<input type="checkbox"/>	u6	g1	Enabled (LAN and WAN)
	<input type="checkbox"/>	u7	g1	Enabled (LAN and WAN)

### 7.1.1 Users and Passwords

*Advanced > Users > Users*

The user configurations allow creating users associated to group. The user settings contain the following key components:

- User Name: This is unique identifier of the user.
- First Name: This is the user’s first name
- Last Name: This is the user’s last name
- Select Group: A group is chosen from a list of configured groups.
- Password: The password associated with the user name.
- Confirm Password: The same password as above is required to mitigate against typing errors.
- Idle Timeout: The session timeout for the user.

It is recommended that passwords contains no dictionary words from any language, and is a mixture of letters (both uppercase and lowercase), numbers, and symbols. The password can be up to 30 characters.

**Figure 92: User configuration options**

DSR-1000N	SETUP	ADVANCED	TOOLS	STATUS
Application Rules	<div style="border: 1px solid black; padding: 5px;"> <div style="background-color: #0056b3; color: white; padding: 2px;"><b>USERS CONFIGURATION</b> <span style="float: right;">LOGOUT</span></div> <div style="background-color: #e0e0e0; padding: 5px; margin-top: 5px;">                     This page allows a user to add new system users.                     <div style="display: flex; justify-content: space-around; margin-top: 5px;"> <span>Save Settings</span> <span>Don't Save Settings</span> </div> </div> <div style="border-top: 1px solid black; padding: 5px; margin-top: 5px;"> <div style="background-color: #333; color: white; padding: 2px;"><b>Users Configuration</b></div> <div style="margin-top: 5px;"> <p><b>User Name:</b> <input type="text" value="Jim"/></p> <p><b>First Name:</b> <input type="text" value="Jim"/></p> <p><b>Last Name:</b> <input type="text" value="George"/></p> <p><b>Select Group:</b> <input type="text" value="ADMIN"/></p> <p><b>Password:</b> <input type="password" value="....."/></p> <p><b>Confirm Password:</b> <input type="password" value="....."/></p> <p><b>Idle Timeout:</b> <input style="border: 2px solid orange;" type="text" value="4"/> (Minutes)</p> </div> </div> </div>			
Website Filter				
Firewall Settings				
Wireless Settings				
Advanced Network				
Routing				
Certificates				
Users				
IP/MAC Binding				
IPv6				
Radius Settings				
Captive Portal				
Switch Settings				
Intel® AMT				

## 7.2 Using SSL VPN Policies

*Setup > VPN Settings > SSL VPN Server > SSL VPN Policies*

SSL VPN Policies can be created on a Global, Group, or User level. User level policies take precedence over Group level policies and Group level policies take precedence over Global policies. These policies can be applied to a specific network resource, IP address or ranges on the LAN, or to different SSL VPN services supported by the router. The List of Available Policies can be filtered based on whether it applies to a user, group, or all users (global).

A more specific policy takes precedence over a generic policy when both are applied to the same user/group/global domain. I.e. a policy for a specific IP address takes precedence over a policy for a range of addresses containing the IP address already referenced.

**Figure 93: List of SSL VPN polices (Global filter)**

To add a SSL VPN policy, you must first assign it to a user, group, or make it global (i.e. applicable to all SSL VPN users). If the policy is for a group, the available configured groups are shown in a drop down menu and one must be selected. Similarly, for a user defined policy a SSL VPN user must be chosen from the available list of configured users.

The next step is to define the policy details. The policy name is a unique identifier for this rule. The policy can be assigned to a specific Network Resource (details follow in the subsequent section), IP address, IP network, or all devices on the LAN of the router. Based on the selection of one of these four options, the appropriate configuration fields are required (i.e. choosing the network resources from a list of defined resources, or defining the IP addresses). For applying the policy to addresses the port range/port number can be defined.

The final steps require the policy permission to be set to either permit or deny access to the selected addresses or network resources. As well the policy can be specified for one or all of the supported SSL VPN services (i.e. VPN tunnel)

Once defined, the policy goes into effect immediately. The policy name, SSL service it applies to, destination (network resource or IP addresses) and permission (deny/permit) is outlined in a list of configured policies for the router.

Figure 94: SSL VPN policy configuration

DSR-1000N	SETUP	ADVANCED	TOOLS	STATUS
Wizard				
Internet Settings				
Wireless Settings				
Network Setting...				
DMZ Setup				
VPN Settings	<div style="text-align: right;">LOGOUT</div> <p><b>SSL VPN POLICY CONFIGURATION</b></p> <p>This page allows you to add a new SSL VPN Policy or edit the configuration of an existing SSL VPN Policy.</p> <p> <input type="button" value="Save Settings"/> <input type="button" value="Don't Save Settings"/> </p>			
USB Settings	<p><b>Policy For</b></p> <p> <b>Policy For:</b> <input type="text" value="Global"/> </p> <p> <b>Available Groups:</b> <input type="text" value="ADMIN"/> </p> <p> <b>Available Users:</b> <input type="text" value="admin"/> </p>			
VLAN Settings	<p><b>SSL VPN Policy</b></p> <p> <b>Apply Policy to:</b> <input type="text" value="Network Resource"/> </p> <p> <b>Policy Name:</b> <input type="text"/> </p> <p> <b>IP Address:</b> <input type="text"/> </p> <p> <b>Mask Length:</b> <input type="text"/> </p> <p> <b>ICMP:</b> <input type="checkbox"/> </p>			
	<p><b>Port Range / Port Number</b></p> <p> <b>Begin:</b> <input type="text"/> (0-65535)                 </p> <p> <b>End:</b> <input type="text"/> (0-65535)                 </p> <p> <b>Service:</b> <input type="text" value="VPN Tunnel"/> </p> <p> <b>Defined Resources:</b> <input type="text"/> </p> <p> <b>Permission:</b> <input type="text" value="Permit"/> </p>			

To configure a policy for a single user or group of users, enter the following information:

- **Policy for:** The policy can be assigned to a group of users, a single user, or all users (making it a global policy). To customize the policy for specific users or groups, the user can select from the Available Groups and Available Users drop down.
- **Apply policy to:** This refers to the LAN resources managed by the DSR, and the policy can provide (or prevent) access to network resources, IP address, IP network, etc.
- **Policy name:** This field is a unique name for identifying the policy.
- **IP address:** Required when the governed resource is identified by its IP address or range of addresses.
- **Mask Length:** Required when the governed resource is identified by a range of addresses within a subnet.

- ICMP: Select this option to include ICMP traffic
- Port range: If the policy governs a type of traffic, this field is used for defining TCP or UDP port number(s) corresponding to the governed traffic. Leaving the starting and ending port range blank corresponds to all UDP and TCP traffic.
- Service: This is the SSL VPN service made available by this policy. The services offered are VPN tunnel, port forwarding or both.
- Defined resources: This policy can provide access to specific network resources. Network resources must be configured in advance of creating the policy to make them available for selection as a defined resource. Network resources are created with the following information
- Permission: The assigned resources defined by this policy can be explicitly permitted or denied.

## 7.2.1 Using Network Resources

### *Setup > VPN Settings > SSL VPN Server > Resources*

Network resources are services or groups of LAN IP addresses that are used to easily create and configure SSL VPN policies. This shortcut saves time when creating similar policies for multiple remote SSL VPN users.

Adding a Network Resource involves creating a unique name to identify the resource and assigning it to one or all of the supported SSL services. Once this is done, editing one of the created network resources allows you to configure the object type (either IP address or IP range) associated with the service. The Network Address, Mask Length, and Port Range/Port Number can all be defined for this resource as required. A network resource can be defined by configuring the following in the GUI:

- Resource name: A unique identifier name for the resource.
- Service: The SSL VPN service corresponding to the resource (VPN tunnel, Port Forwarding or All).

**Figure 95: List of configured resources, which are available to assign to SSL VPN policies**

The screenshot shows the configuration page for a Unified Services Router. On the left is a navigation menu with options like Wizard, Internet Settings, Wireless Settings, Network Settings, DMZ Setup, VPN Settings, USB Settings, and VLAN Settings. The main content area is titled 'RESOURCES' and includes a 'LOGOUT' link. Below this is a text box explaining that resources are groups of host names, IP addresses, or IP networks. A table titled 'List of Resources' contains one entry: 'DocServer' with the service 'VPN Tunnel'. At the bottom of the table are three buttons: 'Delete', 'Configure', and 'Add'.

## 7.3 Application Port Forwarding

### *Setup > VPN Settings > SSL VPN Server > Port Forwarding*

Port forwarding allows remote SSL users to access specified network applications or services after they login to the User Portal and launch the Port Forwarding service. Traffic from the remote user to the router is detected and re-routed based on configured port forwarding rules.

Internal host servers or TCP applications must be specified as being made accessible to remote users. Allowing access to a LAN server requires entering the local server IP address and TCP port number of the application to be tunnelled. The table below lists some common applications and corresponding TCP port numbers:

TCP Application	Port Number
FTP Data (usually not needed)	20
FTP Control Protocol	21
SSH	22
Telnet	23
SMTP (send mail)	25
HTTP (web)	80
POP3 (receive mail)	110
NTP (network time protocol)	123
Citrix	1494
Terminal Services	3389
VNC (virtual network computing)	5900 or 5800



As a convenience for remote users, the hostname (FQDN) of the network server can be configured to allow for IP address resolution. This host name resolution provides users with easy-to-remember FQDN's to access TCP applications instead of error-prone IP addresses when using the Port Forwarding service through the SSL User Portal.

To configure port forwarding, following are required:

- Local Server IP address: The IP address of the local server which is hosting the application.
- TCP port: The TCP port of the application

Once the new application is defined it is displayed in a list of configured applications for port forwarding.

allow users to access the private network servers by using a hostname instead of an IP address, the FQDN corresponding to the IP address is defined in the port forwarding host configuration section.

- Local server IP address: The IP address of the local server hosting the application. The application should be configured in advance.
- Fully qualified domain name: The domain name of the internal server is to be specified

Once the new FQDN is configured, it is displayed in a list of configured hosts for port forwarding.

 Defining the hostname is optional as minimum requirement for port forwarding is identifying the TCP application and local server IP address. The local server IP address of the configured hostname must match the IP address of the configured application for port forwarding.

**Figure 96: List of Available Applications for SSL Port Forwarding**

DSR-1000N	SETUP	ADVANCED	TOOLS	STATUS
Wizard				
Internet Settings	<b>PORT FORWARDING</b> <span style="float: right;">LOGOUT</span>			
Wireless Settings	The Port Forwarding page allows you to detect and re-route data sent from remote users to the SSL VPN gateway to predefined applications running on private networks.			
Network Settings				
DMZ Setup				
VPN Settings	<b>List of Configured Applications for Port Forwarding</b>			
USB Settings	<input type="checkbox"/>	<b>Local Server IP Address</b>	<b>TCP Port Number</b>	
VLAN Settings	<input type="checkbox"/>	97.0.0.64	125	
		<input type="button" value="Delete"/>	<input type="button" value="Add"/>	
	<b>List of Configured Host Names for Port Forwarding</b>			
	<input type="checkbox"/>	<b>Local Server IP Address</b>	<b>Fully Qualified Domain Name</b>	
	<input type="checkbox"/>	192.168.15.25	test	
		<input type="button" value="Delete"/>	<input type="button" value="Add"/>	

## 7.4 SSL VPN Client Configuration

*Setup > VPN Settings > SSL VPN Client > SSL VPN Client*

An SSL VPN tunnel client provides a point-to-point connection between the browser-side machine and this router. When a SSL VPN client is launched from the user portal, a "network adapter" with an IP address from the corporate subnet, DNS and WINS settings is automatically created. This allows local applications to access services on the private network without any special network configuration on the remote SSL VPN client machine.

It is important to ensure that the virtual (PPP) interface address of the VPN tunnel client does not conflict with physical devices on the LAN. The IP address range for the SSL VPN virtual network adapter should be either in a different subnet or non-overlapping range as the corporate LAN.

 The IP addresses of the client's network interfaces (Ethernet, Wireless, etc.) cannot be identical to the router's IP address or a server on the corporate LAN that is being accessed through the SSL VPN tunnel.

**Figure 97: SSL VPN client adapter and access configuration**

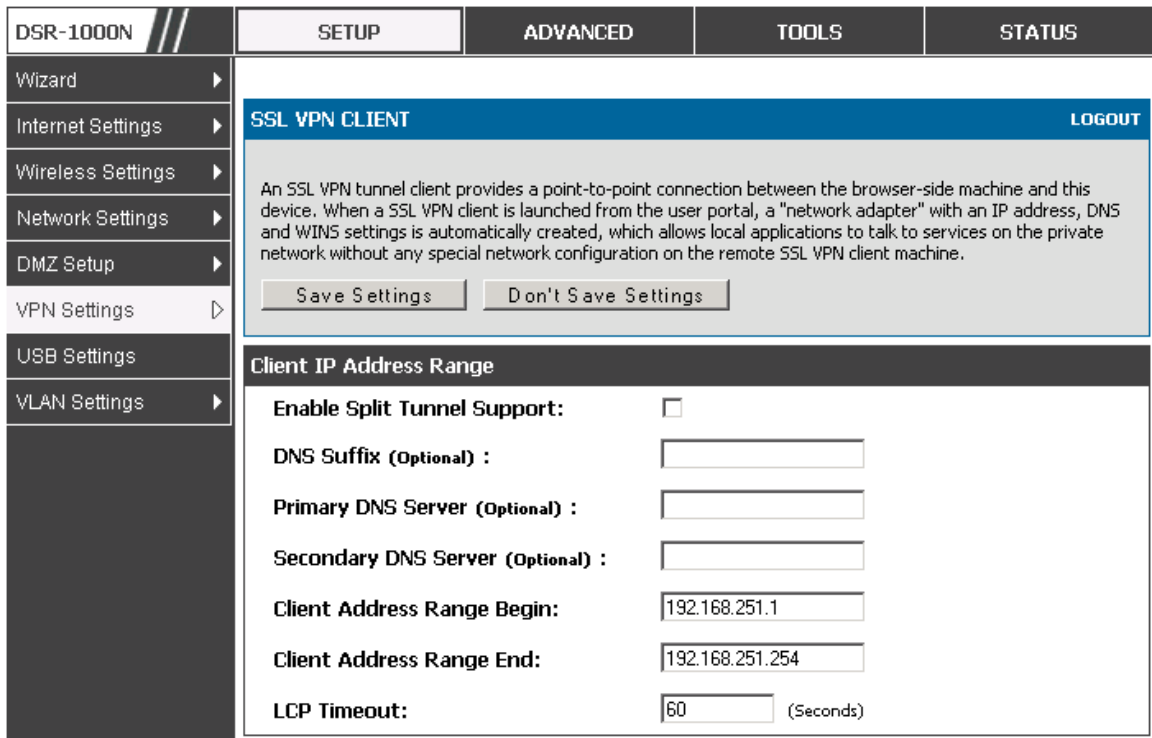

The router allows full tunnel and split tunnel support. Full tunnel mode just sends all traffic from the client across the VPN tunnel to the router. Split tunnel mode only sends traffic to the private LAN based on pre-specified client routes. These client routes give the SSL client access to specific private networks, thereby allowing access control over specific LAN services.

Client level configuration supports the following:

- **Enable Split Tunnel Support:** With a split tunnel, only resources which are referenced by client routes can be accessed over the VPN tunnel. With full tunnel support (if the split tunnel option is disabled the DSR acts in full tunnel mode) all addresses on the private network are accessible over the VPN tunnel. Client routes are not required.
- **DNS Suffix:** The DNS suffix name which will be given to the SSL VPN client. This configuration is optional.
- **Primary DNS Server:** DNS server IP address to set on the network adaptor created on the client host. This configuration is optional.
- **Secondary DNS Server:** Secondary DNS server IP address to set on the network adaptor created on the client host. This configuration is optional.
- **Client Address Range Begin:** Clients who connect to the tunnel get a DHCP served IP address assigned to the network adaptor from the range of addresses beginning with this IP address

**Client Address Range End:** The ending IP address of the DHCP range of addresses served to the client network adaptor.

*Setup > VPN Settings > SSL VPN Client > Configured Client Routes*

If the SSL VPN client is assigned an IP address in a different subnet than the corporate network, a client route must be added to allow access to the private LAN through the VPN tunnel. As well a static route on the private LAN's firewall (typically this router) is needed to forward private traffic through the VPN Firewall to the remote SSL VPN client. When split tunnel mode is enabled, the user is required to configure routes for VPN tunnel clients:

- Destination network: The network address of the LAN or the subnet information of the destination network from the VPN tunnel clients' perspective is set here.
- Subnet mask: The subnet information of the destination network is set here.

**Figure 98: Configured client routes only apply in split tunnel mode**

DSR-1000N	SETUP	ADVANCED	TOOLS	STATUS
Wizard	<div style="border: 1px solid black; padding: 5px;"> <div style="background-color: #0056b3; color: white; padding: 2px;"><b>SSL VPN CLIENT ROUTE CONFIGURATION</b> <span style="float: right;">LOGOUT</span></div> <p>The Configured Client Routes entries are the routing entries which will be added by the SSL VPN Client such that only traffic to these destination addresses is redirected through the SSL VPN tunnels. All other traffic is redirected using the native network interface of the hosts (SSL VPN Clients). For example if the SSL VPN Client wishes to access the LAN network, then in SPLIT Tunnel mode you should add the LAN subnet as the Destination Network.</p> <div style="text-align: center;"> <input type="button" value="Save Settings"/> <input type="button" value="Don't Save Settings"/> </div> </div>			
Internet Settings				
Wireless Settings				
Network Settings				
DMZ Setup				
VPN Settings				
USB Settings				
VLAN Settings				
	<div style="border: 1px solid black; padding: 5px;"> <div style="background-color: #333; color: white; padding: 2px;"><b>SSL VPN Client Route Configuration</b></div> <p><b>Destination Network:</b> <input style="width: 100px;" type="text"/></p> <p><b>Subnet Mask:</b> <input style="width: 100px;" type="text"/></p> </div>			

**✎ Steps to Install/Uninstall SSLVPN tunnel in MAC OS**

- ✎ 1. Open terminal and run "visudo" as root and it will open sudoers file
- ✎ 2. Add "username ALL=NOPASSWD: /usr/sbin/chown,/bin/chmod,/bin/rm" at the bottom of the sudoers file, save and close the file. (Username is the user name of the MAC account but not SSLVPN user name).
- ✎ While uninstalling SSLVPN tunnel, when it asks for password, enter the MAC user account password but not root password or sslvpn user password

## 7.5 User Portal

*Setup > VPN Settings > SSL VPN Client > SSL VPN Client Portal*

When remote users want to access the private network through an SSL tunnel (either using the Port Forwarding or VPN tunnel service), they login through a user portal. This portal provides the authentication fields to provide the appropriate access levels and privileges as determined by the router administrator. The domain where the user account is stored must be specified, and the domain determines the authentication method and portal layout screen presented to the remote user.

**Figure 99: List of configured SSL VPN portals. The configured portal can then be associated with an authentication domain**

Layout Name	Use Count	Portal URL
SSLVPN*	1	https://0.0.0.0/portal/SSLVPN
MarketingAccess	0	https://0.0.0.0/portal/MarketingAccess

### 7.5.1 Creating Portal Layouts

*Setup > VPN Settings > SSL VPN Server > Portal Layouts*

The router allows you to create a custom page for remote SSL VPN users that is presented upon authentication. There are various fields in the portal that are customizable for the domain, and this allows the router administrator to communicate details such as login instructions, available services, and other usage details in the portal visible to remote users. During domain setup, configured portal layouts are available to select for all users authenticated by the domain.

The default portal LAN IP address is <https://192.168.10.1/scgi-bin/userPortal/portal>. This is the same page that opens when the “User Portal” link is clicked on the SSL VPN menu of the router GUI.

The router administrator creates and edits portal layouts from the configuration pages in the SSL VPN menu. The portal name, title, banner name, and banner contents are all customizable to the intended users for this portal. The portal name is appended to

the SSL VPN portal URL. As well, the users assigned to this portal (through their authentication domain) can be presented with one or more of the router's supported SSL services such as the VPN Tunnel page or Port Forwarding page.

To configure a portal layout and theme, following information is needed:

- **Portal layout name:** A descriptive name for the custom portal that is being configured. It is used as part of the SSL portal URL.
- **Portal site title:** The portal web browser window title that appears when the client accesses this portal. This field is optional.
- **Banner title:** The banner title that is displayed to SSL VPN clients prior to login. This field is optional.
- **Banner message:** The banner message that is displayed to SSL VPN clients prior to login. This field is optional.
- **Display banner message on the login page:** The user has the option to either display or hide the banner message in the login page.
- **HTTP meta tags for cache control:** This security feature prevents expired web pages and data from being stored in the client's web browser cache. It is recommended that the user selects this option.
- **ActiveX web cache cleaner:** An ActiveX cache control web cleaner can be pushed from the gateway to the client browser whenever users login to this SSL VPN portal.
- **SSL VPN portal page to display:** The User can either enable VPN tunnel page or Port Forwarding, or both depending on the SSL services to display on this portal.

Once the portal settings are configured, the newly configured portal is added to the list of portal layouts.

Figure 100: SSL VPN Portal configuration

<b>DSR-1000N</b> //	<b>SETUP</b>	<b>ADVANCED</b>	<b>TOOLS</b>	<b>STATUS</b>
Wizard ▶	<b>PORTAL LAYOUT CONFIGURATION</b> <span style="float: right;">LOGOUT</span> <p>This page allows you to add a new portal layout or edit the configuration of an existing portal layout. The details will then be displayed in the List of Portal Layouts table on the SSL VPN Server&gt; Portal Layouts page under the VPN menu.</p> <p><input type="button" value="Save Settings"/> <input type="button" value="Don't Save Settings"/></p> <hr/> <b>Portal Layout and Theme Name</b> <p><b>Portal Layout Name:</b> <input type="text"/></p> <p><b>Profile Name (Optional) :</b> <input type="text"/></p> <p><b>Portal Site Title (Optional) :</b> <input type="text"/></p> <p><b>Banner Title (Optional) :</b> <input type="text"/></p> <p><b>Banner Message (Optional) :</b> <input type="text"/></p> <p><b>Display banner message on login page:</b> <input type="checkbox"/></p> <p><b>HTTP meta tags for cache control(recommended):</b> <input type="checkbox"/></p>			
Internet Settings ▶				
Wireless Settings ▶				
Network Setting... ▶				
DMZ Setup ▶				
VPN Settings ▶				
USB Settings ▶				
VLAN Settings ▶				

# Chapter 8. Advanced Configuration Tools

## 8.1 USB Device Setup

### *Setup > USB Settings > USB Status*

The DSR Unified Services Router has a USB interface for printer access, file sharing and on the DSR-1000 / DSR-1000N models 3G modem support. There is no configuration on the GUI to enable USB device support. Upon inserting your USB storage device, printer cable or 3G modem the DSR router will automatically detect the type of connected peripheral.



- USB Mass Storage: also referred to as a “share port”, files on a USB disk connected to the DSR can be accessed by LAN users as a network drive.
- USB Printer: The DSR can provide the LAN with access to printers connected through the USB. The printer driver will have to be installed on the LAN host and traffic will be routed through the DSR between the LAN and printer.
- USB 3G modem: A 3G modem dongle can be plugged in and used as a secondary WAN. Load balancing, auto-failover, or primary WAN access can be configured through the 3G interface.

To configure printer on a Windows machine, follow below given steps:

- Click 'Start' on the desktop.
- Select 'Printers and faxes' option.
- Right click and select 'add printer' or click on 'Add printer' present at the left menu.
- Select the 'Network Printer' radio button and click next (select "device isn't listed in case of Windows 7").
- Select the 'Connect to printer using URL' radio button ('Select a shared printer by name 'in case of Windows 7) and give the following URL `http://<Router's LAN IP address>:631/printers/<Model Name>` (Model Name can be found in the USB status page of router's GUI).
- Click 'next' and select the appropriate driver from the displayed list.
- Click on 'next' and 'finish' to complete adding the printer.



**Figure 101: USB Device Detection**

DSR-1000N	SETUP	ADVANCED	TOOLS	STATUS
Wizard				
Internet Settings				
Wireless Settings				
Network Setting...				
DMZ Setup				
VPN Settings				
USB Settings	<b>USB SETTINGS</b>			LOGOUT
VLAN Settings	<p>This page displays information about the USB devices connected to the USB port(s). This page also allows user to do certain configurations on USB devices, such as safely unmounting the devices.</p>			
	<b>USB-1: Device Not Connected</b>			
		<b>Device Vendor:</b>	NA	
		<b>Device Model:</b>	NA	
		<b>Device Type:</b>	NA	
		<b>Mount Status:</b>	NA	
	<b>USB-2: Device Not Connected</b>			
		<b>Device Vendor:</b>	NA	
		<b>Device Model:</b>	NA	
		<b>Device Type:</b>	NA	
		<b>Mount Status:</b>	NA	

## 8.2 USB share port

*Setup > USB Settings > USB SharePort*

This page allows configure the SharePort feature available in this router.

Figure 102: USB SharePort

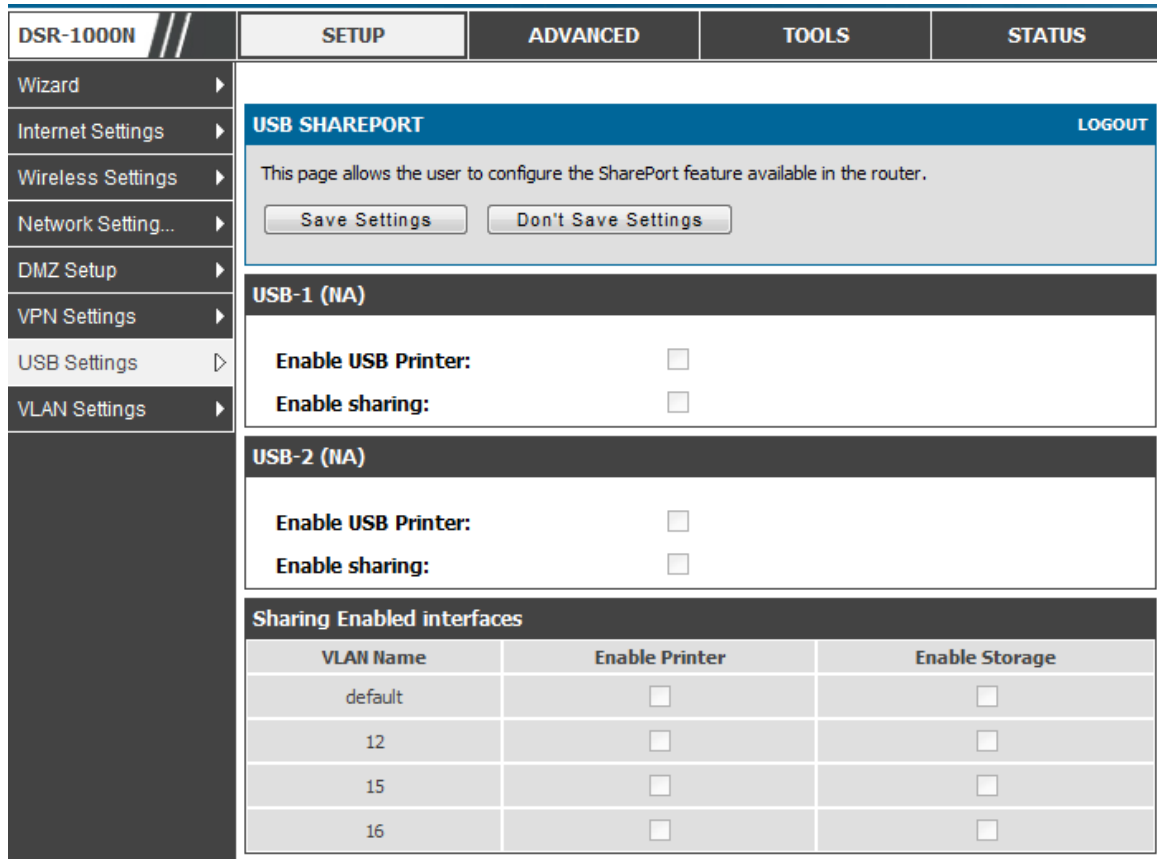

**USB-1:**

Enable USB Printer: Select this option to allow the USB printer connected to the router to be shared across the network.

The USB printer can be accessed on any LAN host (with appropriate printer driver installed) connected to the router by using the following command in the host's add printers window

http://<Router's IP:631>/printers/<Device Model> (Device Model can be found in the USB settings page).

Enable Sharing: Select this option to allow the USB storage device connected to the router to be shared across the network.

**USB-2:**

Enable USB Printer: Select this option to allow the USB printer connected to the router to be shared across the network.

The USB printer can be accessed on any LAN host (with appropriate printer driver installed) connected to the router by using the following command in the host's add printers window

http://<Router's IP:631>/printers/<Device Model> (Device Model can be found in the USB settings page).

Enable Sharing: Select this option to allow the USB storage device connected to the router to be shared across the network.

**Sharing Enabled interfaces:**

The LAN interfaces on which USB sharing is enabled, atleast one interface must be selected to begin sharing.

Enable Printer: Enables printer sharing on the selected interface.

Enable Storage: Enables storage device sharing on the selected interface.

## 8.3 SMS service

*Setup > USB Settings > SMS Service*

The DSR Unified Services Router has a USB interface to connect 3G modem support to send and receive Short Messaging Service. The received messages can be seen in the Inbox and allows the user to create a new SMS. If WAN3 is used in dedicated wan mode, load balancing mode or if 3G USB Device is not connected to router then the controls on this page will be greyed out.

**Figure 103: SMS Service – Send SMS**

DSR-1000N	SETUP	ADVANCED	TOOLS	STATUS
Wizard	SMS INBOX <span style="float: right;">LOGOUT</span>			
Internet Settings	SMS INBOX			
Wireless Settings	SMS INBOX			
Network Settings	SMS INBOX			
DMZ Setup	<input type="checkbox"/>	Sno	Sender	Timestamp
VPN Settings	<input type="checkbox"/>	0	8468451099710510850115109115	11/03/12,05:57:15+22
USB Settings	BSNL gives you email on mobile Works on all mobile sets, It's as simple as SMS only Rs 49 per month for unlimited emails Try now send SMSMAIL to 56688			
VLAN Settings				

The following details are displayed in SMS INBOX page:

- Sno: Displays the serial number of message in the inbox.
- Sender: Displays the sender of the particular message.
- TimeStamp: Displays the time when the message was sent
- Text: Displays the content of the particular Message.

The following actions are performed:

- Delete: Deletes the SMS having that particular Sno. Only one message can be deleted at a time.
- Refresh: Updates the inbox with new SMS (if any).
- Reply: Lets the user create a new SMS in reply to a particular message by the selected sender. "Receiver" field in the createSms.htm page is filled with the sender's number.
- Forward: Lets the user forward a selected SMS. "Text Message" field in the createSms.htm page is filled with the "Text" of the selected message.

**Figure 104: SMS Service – Receive SMS**

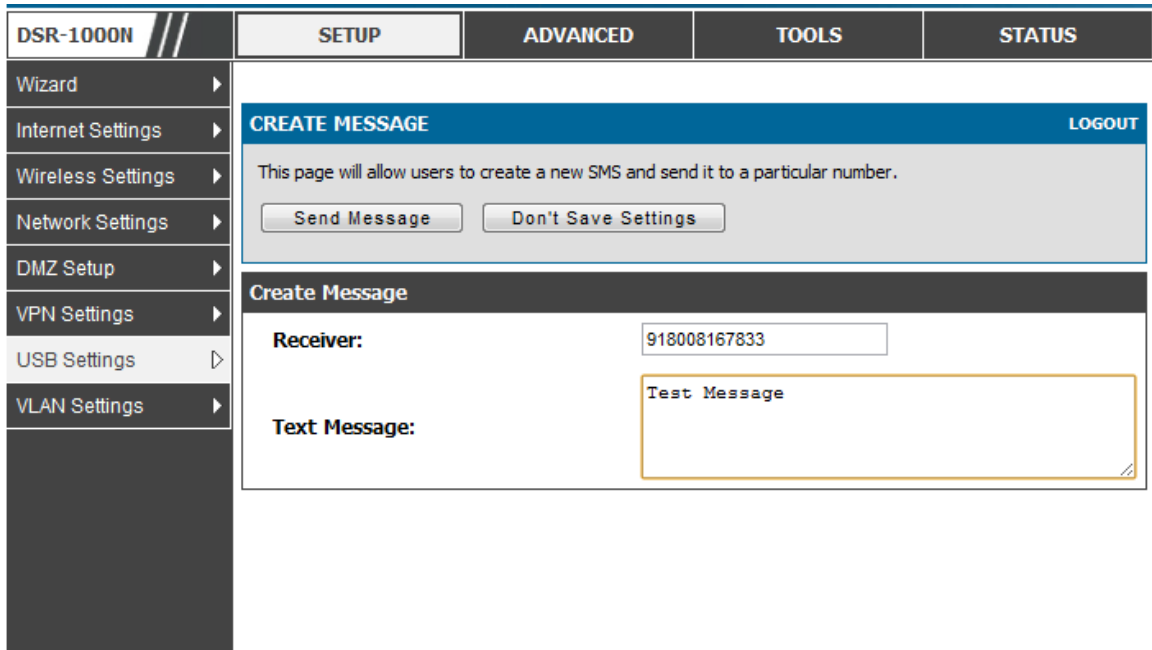

The following details to be provided in Create Message page:

- Receiver: Enter the phone number of the intended receiver of the message.
- Text Message: Enter the body of the message here

Click Send Message to send the message.

Click Don't Save Settings to reset Receiver and Text Message fields.

## 8.4 Authentication Certificates

### *Advanced > Certificates*

This gateway uses digital certificates for IPsec VPN authentication as well as SSL validation (for HTTPS and SSL VPN authentication). You can obtain a digital certificate from a well-known Certificate Authority (CA) such as VeriSign, or generate and sign your own certificate using functionality available on this gateway. The gateway comes with a self-signed certificate, and this can be replaced by one signed by a CA as per your networking requirements. A CA certificate provides strong assurance of the server's identity and is a requirement for most corporate network VPN solutions.

The certificates menu allows you to view a list of certificates (both from a CA and self-signed) currently loaded on the gateway. The following certificate data is displayed in the list of Trusted (CA) certificates:

CA Identity (Subject Name): The certificate is issued to this person or organization

Issuer Name: This is the CA name that issued this certificate

Expiry Time: The date after which this Trusted certificate becomes invalid

A self certificate is a certificate issued by a CA identifying your device (or self-signed if you don't want the identity protection of a CA). The Active Self Certificate

table lists the self certificates currently loaded on the gateway. The following information is displayed for each uploaded self certificate:

- Name: The name you use to identify this certificate, it is not displayed to IPsec VPN peers or SSL users.
- Subject Name: This is the name that will be displayed as the owner of this certificate. This should be your official registered or company name, as IPsec or SSL VPN peers are shown this field.
- Serial Number: The serial number is maintained by the CA and used to identify this signed certificate.
- Issuer Name: This is the CA name that issued (signed) this certificate
- Expiry Time: The date after which this signed certificate becomes invalid – you should renew the certificate before it expires.

To request a self certificate to be signed by a CA, you can generate a Certificate Signing Request from the gateway by entering identification parameters and passing it along to the CA for signing. Once signed, the CA’s Trusted Certificate and signed certificate from the CA are uploaded to activate the self-certificate validating the identity of this gateway. The self certificate is then used in IPsec and SSL connections with peers to validate the gateway’s authenticity.

**Figure 105: Certificate summary for IPsec and HTTPS management**

DSR-1000N	SETUP	ADVANCED	TOOLS	STATUS
-----------	-------	----------	-------	--------

Application Rules ▶	<div style="background-color: #0056b3; color: white; padding: 5px;"><b>CERTIFICATES</b> <span style="float: right;">LOGOUT</span></div> <p style="font-size: small; margin-top: 10px;">Digital Certificates (also known as X509 Certificates) are used to authenticate the identity of users and systems, and are issued by Certification Authorities (CA) such as VeriSign, Thawte and other organizations. Digital Certificates are used by this router during the Internet Key Exchange (IKE) authentication phase to authenticate connecting VPN gateways or clients, or to be authenticated by remote entities.</p> <div style="background-color: #333; color: white; padding: 2px;"><b>Trusted Certificates (CA Certificate)</b></div> <table border="1" style="width: 100%; border-collapse: collapse; font-size: small;"> <thead> <tr> <th style="width: 5%;"><input type="checkbox"/></th> <th style="width: 45%;">CA Identity (Subject Name)</th> <th style="width: 25%;">Issuer Name</th> <th style="width: 25%;">Expiry Time</th> </tr> </thead> <tbody> <tr> <td colspan="4" style="text-align: center; padding: 5px;"> <div style="display: flex; justify-content: space-around;"> <span>Upload</span> <span>Delete</span> </div> </td> </tr> </tbody> </table> <div style="background-color: #333; color: white; padding: 2px; margin-top: 5px;"><b>Active Self Certificates</b></div> <table border="1" style="width: 100%; border-collapse: collapse; font-size: small;"> <thead> <tr> <th style="width: 5%;"><input type="checkbox"/></th> <th style="width: 15%;">Name</th> <th style="width: 20%;">Subject Name</th> <th style="width: 20%;">Serial Number</th> <th style="width: 20%;">Issuer Name</th> <th style="width: 20%;">Expiry Time</th> </tr> </thead> <tbody> <tr> <td colspan="6" style="text-align: center; padding: 5px;"> <div style="display: flex; justify-content: space-around;"> <span>Upload</span> <span>Delete</span> </div> </td> </tr> </tbody> </table> <div style="background-color: #333; color: white; padding: 2px; margin-top: 5px;"><b>Self Certificate Requests</b></div> <table border="1" style="width: 100%; border-collapse: collapse; font-size: small;"> <thead> <tr> <th style="width: 5%;"><input type="checkbox"/></th> <th style="width: 30%;">Name</th> <th style="width: 40%;">Status</th> <th style="width: 25%;">Action</th> </tr> </thead> <tbody> <tr> <td><input type="checkbox"/></td> <td>Router_1</td> <td>Active Self Certificate Not Uploaded</td> <td style="text-align: center;"><span>View</span></td> </tr> </tbody> </table> <div style="text-align: center; padding: 5px; margin-top: 5px;"> <div style="display: flex; justify-content: space-around;"> <span>New Self Certificate</span> <span>Delete</span> </div> </div>	<input type="checkbox"/>	CA Identity (Subject Name)	Issuer Name	Expiry Time	<div style="display: flex; justify-content: space-around;"> <span>Upload</span> <span>Delete</span> </div>				<input type="checkbox"/>	Name	Subject Name	Serial Number	Issuer Name	Expiry Time	<div style="display: flex; justify-content: space-around;"> <span>Upload</span> <span>Delete</span> </div>						<input type="checkbox"/>	Name	Status	Action	<input type="checkbox"/>	Router_1	Active Self Certificate Not Uploaded	<span>View</span>
<input type="checkbox"/>		CA Identity (Subject Name)	Issuer Name	Expiry Time																									
<div style="display: flex; justify-content: space-around;"> <span>Upload</span> <span>Delete</span> </div>																													
<input type="checkbox"/>		Name	Subject Name	Serial Number	Issuer Name	Expiry Time																							
<div style="display: flex; justify-content: space-around;"> <span>Upload</span> <span>Delete</span> </div>																													
<input type="checkbox"/>		Name	Status	Action																									
<input type="checkbox"/>		Router_1	Active Self Certificate Not Uploaded	<span>View</span>																									
Website Filter ▶																													
Firewall Settings ▶																													
Wireless Settings ▶																													
Advanced Network ▶																													
Routing ▶																													
Certificates																													
Users ▶																													
IP/MAC Binding																													
IPv6 ▶																													
Radius Settings																													
Power Saving																													

## 8.5 Advanced Switch Configuration

The DSR allows you to adjust the power consumption of the hardware based on your actual usage. The two “green” options available for your LAN switch are Power Saving by Link Status and Length Detection State. With “Power Saving by Link Status” option enabled, the total power consumption by the LAN switch is dependent function of on the number of connected ports. The overall current draw when a single port is connected is less than when all the ports are connected. With “Length Detection State” option enabled, the overall current supplied to a LAN port is reduced when a smaller cable length is connected on a LAN port.

Jumbo Frames support can be configured as an advanced switch configuration. Jumbo frames are Ethernet frames with more than 1500 bytes of payload. When this option is enabled, the LAN devices can exchange information at Jumbo frames rate.

**Figure 106: Advanced Switch Settings**

SETUP	<b>ADVANCED</b>	TOOLS	STATUS
-------	-----------------	-------	--------

<b>SWITCH SETTINGS</b>		LOGOUT
This page allows user to enable/disable power saving, jumbo frames in the router.		
Save Settings		Don't Save Settings
<b>Power Saving Options</b>		
Power Saving by Link Status:	<input checked="" type="checkbox"/>	
Power Saving by Cable Length:	<input checked="" type="checkbox"/>	
<b>Jumbo Frames Option</b>		
Enable Jumbo Frames:	<input type="checkbox"/>	

# Chapter 9. Administration & Management

## 9.1 Configuration Access Control

The primary means to configure this gateway via the browser-independent GUI. The GUI can be accessed from LAN node by using the gateway’s LAN IP address and HTTP, or from the WAN by using the gateway’s WAN IP address and HTTPS (HTTP over SSL).

Administrator and Guest users are permitted to login to the router’s management interface. The user type is set in the *Advanced > Users > Users* page. The Admin or Guest user can be configured to access the router GUI from the LAN or the Internet (WAN) by enabling the corresponding Login Policy.

**Figure 107: User Login policy configuration**

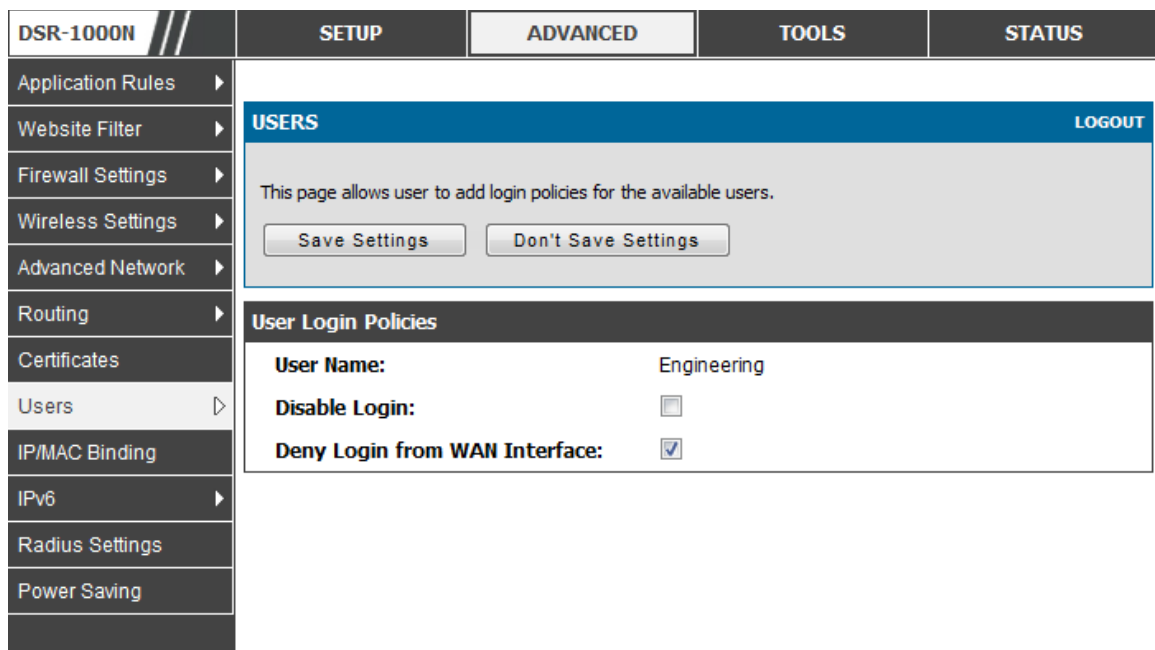

### 9.1.1 Admin Settings

*Tools > Admin > Admin settings*

This page allows to provide the name of the router.

**Figure 108: Admin Settings**

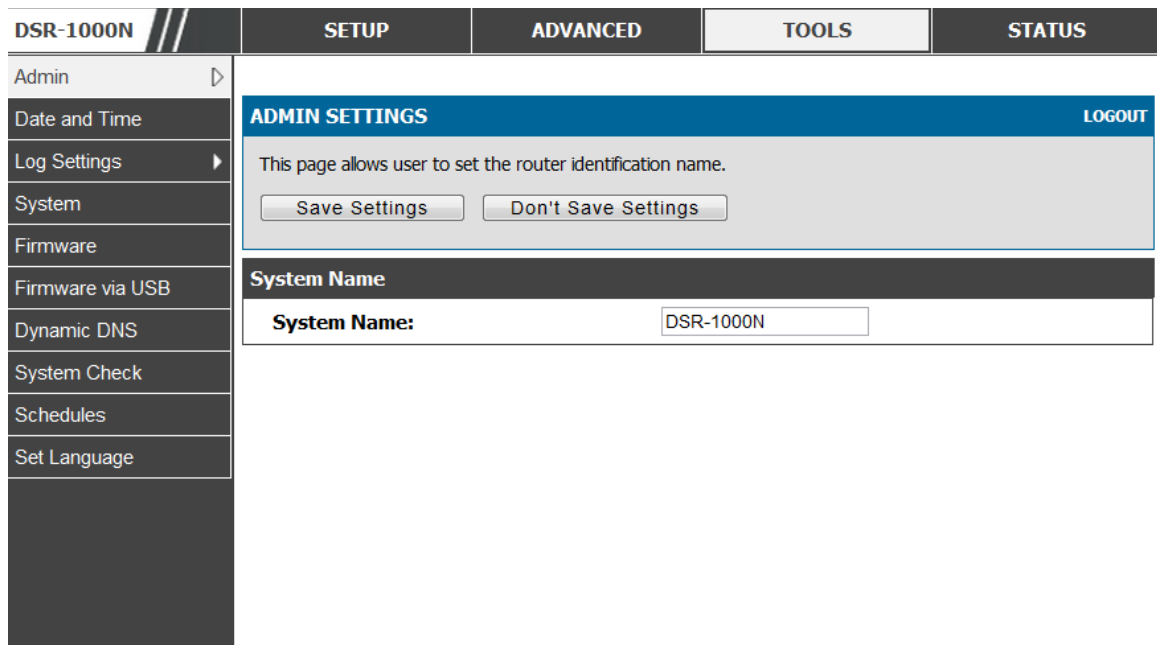

## 9.1.2 Remote Management

### *Tools > Admin > Remote Management*

Both HTTPS and telnet access can be restricted to a subset of IP addresses. The router administrator can define a known PC, single IP address or range of IP addresses that are allowed to access the GUI with HTTPS. The opened port for SSL traffic can be changed from the default of 443 at the same time as defining the allowed remote management IP address range.



**Figure 109: Remote Management from the WAN**

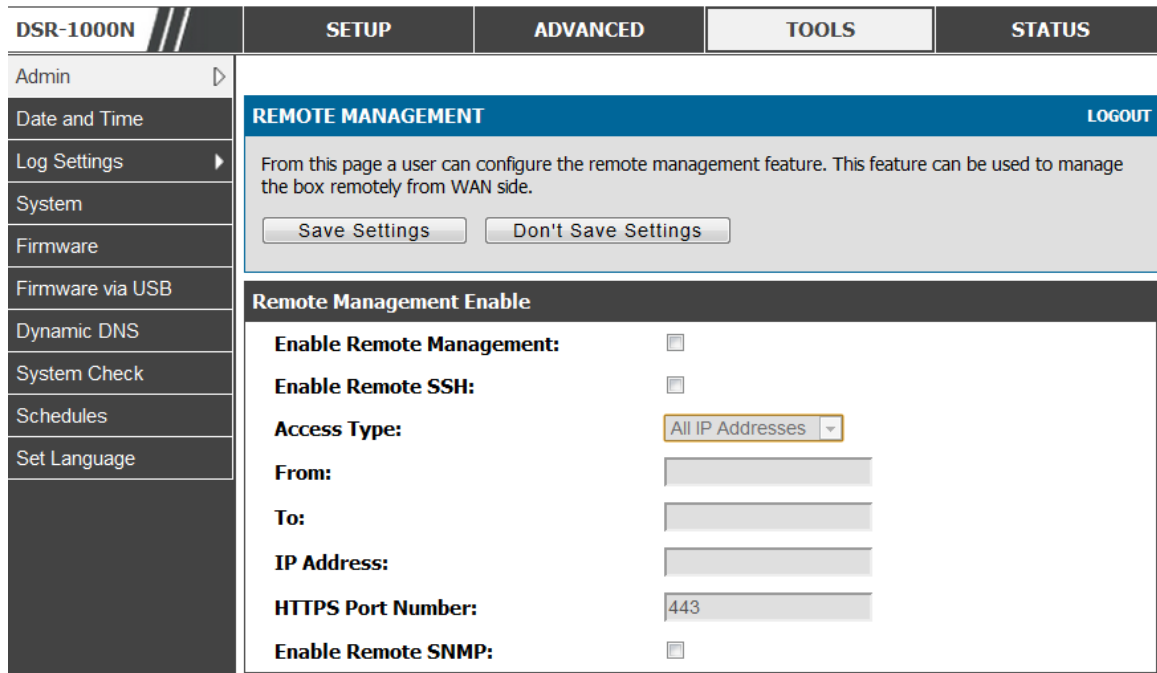

### 9.1.3 CLI Access

In addition to the web-based GUI, the gateway supports SSH and Telnet management for command-line interaction. The CLI login credentials are shared with the GUI for administrator users. To access the CLI, type “cli” in the SSH or console prompt and login with administrator user credentials.

## 9.2 SNMP Configuration

*Tools > Admin > SNMP*

SNMP is an additional management tool that is useful when multiple routers in a network are being managed by a central Master system. When an external SNMP manager is provided with this router’s Management Information Base (MIB) file, the manager can update the router’s hierarchal variables to view or update configuration parameters. The router as a managed device has an SNMP agent that allows the MIB configuration variables to be accessed by the Master (the SNMP manager). The Access Control List on the router identifies managers in the network that have read-only or read-write SNMP credentials. The Traps List outlines the port over which notifications from this router are provided to the SNMP community (managers) and also the SNMP version (v1, v2c, v3) for the trap.

**Figure 110: SNMP Users, Traps, and Access Control**

DSR-1000N	SETUP	ADVANCED	TOOLS	STATUS
-----------	-------	----------	-------	--------

Admin ▾

Date and Time

Log Settings ▸

System

Firmware

Firmware via USB

Dynamic DNS

System Check

Schedules

Set Language

**SNMP** LOGOUT

Simple Network Management Protocol (SNMP) lets you monitor and manage your router from an SNMP manager. SNMP provides a remote means to monitor and control network devices, and to manage configurations, statistics collection, performance, and security.

**SNMP v3 Users List**

	Name	Privilege	Security level
<input type="checkbox"/>	admin	RWUSER	NoAuthNoPriv
<input type="checkbox"/>	guest	ROUSER	NoAuthNoPriv

**Traps List**

	IP Address	Port	Community	SNMP Version
<input type="checkbox"/>				

**Access Control List**

	IP Address	Subnet Mask	Community	Access Type
<input type="checkbox"/>				

*Tools > Admin > SNMP System Info*

The router is identified by an SNMP manager via the System Information. The identifier settings The SysName set here is also used to identify the router for SysLog logging.

**Figure 111: SNMP system information for this router**

DSR-1000N	SETUP	ADVANCED	TOOLS	STATUS
Admin				
Date and Time	<b>SNMP</b> <span style="float: right;">LOGOUT</span>			
Log Settings	This page displays the current SNMP configuration of the router. The following MIB (Management Information Base) fields are displayed and can be modified here.			
System	<input type="button" value="Save Settings"/> <input type="button" value="Don't Save Settings"/>			
Firmware	<b>SNMP System Information</b>			
Firmware via USB	<b>SysContact:</b>	<input type="text"/>		
Dynamic DNS	<b>SysLocation:</b>	<input type="text"/>		
System Check	<b>SysName:</b>	<input type="text" value="DSR-1000N"/>		
Schedules				
Set Language				

## 9.3 Configuring Time Zone and NTP

### *Tools > Date and Time*

You can configure your time zone, whether or not to adjust for Daylight Savings Time, and with which Network Time Protocol (NTP) server to synchronize the date and time. You can choose to set Date and Time manually, which will store the information on the router’s real time clock (RTC). If the router has access to the internet, the most accurate mechanism to set the router time is to enable NTP server communication.

 Accurate date and time on the router is critical for firewall schedules, Wi-Fi power saving support to disable APs at certain times of the day, and accurate logging.

Please follow the steps below to configure the NTP server:

1. Select the router’s time zone, relative to Greenwich Mean Time (GMT).
2. If supported for your region, click to Enable Daylight Savings.
3. Determine whether to use default or custom Network Time Protocol (NTP) servers. If custom, enter the server addresses or FQDN.

Figure 112: Date, Time, and NTP server setup

DSR-1000N	SETUP	ADVANCED	TOOLS	STATUS
-----------	-------	----------	-------	--------

<ul style="list-style-type: none"> <li>Admin</li> <li>Date and Time</li> <li>Log Settings</li> <li>System</li> <li>Firmware</li> <li>Firmware via USB</li> <li>Dynamic DNS</li> <li>System Check</li> <li>Schedules</li> <li>Set Language</li> </ul>	<div style="background-color: #0070C0; color: white; padding: 2px;"><b>DATE AND TIME</b></div> <div style="text-align: right; font-size: small; color: #0070C0;">LOGOUT</div> <p style="font-size: x-small; margin-top: 5px;">This page allows us to set the date, time and NTP servers. Network Time Protocol (NTP) is a protocol that is used to synchronize computer clock time in a network of computers. Accurate time across a network is important for many reasons.</p> <div style="text-align: center; margin-top: 5px;"> <input type="button" value="Save Settings"/> <input type="button" value="Don't Save Settings"/> </div> <hr/> <div style="background-color: #333; color: white; padding: 2px;"><b>Date and Time</b></div> <p><b>Current Router Time:</b> Sat Feb 4 17:26:27 GMT 2012</p> <p><b>Time Zone:</b> (GMT+05:30) Chennai Kolkata Mumbai New Delhi</p> <p><b>Enable Daylight Saving:</b> <input type="checkbox"/></p> <p><b>Configure NTP Servers:</b> <input checked="" type="radio"/></p> <p><b>Set Date and Time Manually:</b> <input type="radio"/></p> <hr/> <div style="background-color: #333; color: white; padding: 2px;"><b>NTP Servers Configuration</b></div> <p><b>Default NTP Server:</b> <input checked="" type="radio"/></p> <p><b>Custom NTP Server:</b> <input type="radio"/></p> <p><b>Primary NTP Server:</b> 0.us.pool.ntp.org</p> <p><b>Secondary NTP Server:</b> 1.us.pool.ntp.org</p> <p><b>Time to re-synchronize (in minutes):</b> 120</p> <hr/> <div style="background-color: #333; color: white; padding: 2px;"><b>Set Date And Time</b></div> <table style="width: 100%; border-collapse: collapse; font-size: x-small;"> <thead> <tr> <th style="border: none;">Year</th> <th style="border: none;">Month</th> <th style="border: none;">Day</th> <th style="border: none;">Hours</th> <th style="border: none;">Min</th> <th style="border: none;">Sec</th> </tr> </thead> <tbody> <tr> <td style="border: 1px solid #ccc; text-align: center;">2012</td> <td style="border: 1px solid #ccc; text-align: center;">/ 02</td> <td style="border: 1px solid #ccc; text-align: center;">/ 04</td> <td style="border: 1px solid #ccc; text-align: center;">- 17</td> <td style="border: 1px solid #ccc; text-align: center;">: 26</td> <td style="border: 1px solid #ccc; text-align: center;">: 27</td> </tr> </tbody> </table>	Year	Month	Day	Hours	Min	Sec	2012	/ 02	/ 04	- 17	: 26	: 27
Year	Month	Day	Hours	Min	Sec								
2012	/ 02	/ 04	- 17	: 26	: 27								

## 9.4 Log Configuration

This router allows you to capture log messages for traffic through the firewall, VPN, and over the wireless AP. As an administrator you can monitor the type of traffic that goes through the router and also be notified of potential attacks or errors when they are detected by the router. The following sections describe the log configuration settings and the ways you can access these logs.

### 9.4.1 Defining What to Log

*Tools > Log Settings > Logs Facility*

The Logs Facility page allows you to determine the granularity of logs to receive from the router. There are three core components of the router, referred to as Facilities:

- **Kernel:** This refers to the Linux kernel. Log messages that correspond to this facility would correspond to traffic through the firewall or network stack.
- **System:** This refers to application and management level features available on this router, including SSL VPN and administrator changes for managing the unit.
- **Wireless:** This facility corresponds to the 802.11 driver used for providing AP functionality to your network.
- **Local1-UTM:** This facility corresponds to IPS (Intrusion Prevention System) which helps in detecting malicious intrusion attempts from the WAN.

For each facility, the following events (in order of severity) can be logged: Emergency, Alert, Critical, Error, Warning, Notification, Information, Debugging. When a particular severity level is selected, all events with severity equal to and greater than the chosen severity are captured. For example if you have configured CRITICAL level logging for the Wireless facility, then 802.11 logs with severities CRITICAL, ALERT, and EMERGENCY are logged. The severity levels available for logging are:

- **EMERGENCY:** system is unusable
- **ALERT:** action must be taken immediately
- **CRITICAL:** critical conditions
- **ERROR:** error conditions
- **WARNING:** warning conditions
- **NOTIFICATION:** normal but significant condition
- **INFORMATION:** informational
- **DEBUGGING:** debug-level messages

**Figure 113: Facility settings for Logging**

DSR-1000N	SETUP	ADVANCED	TOOLS	STATUS																											
Admin																															
Date and Time																															
Log Settings	<div style="border: 1px solid black; padding: 5px;"> <p><b>LOGS FACILITY</b> <span style="float: right;">LOGOUT</span></p> <p>This page allows user to set the date and time for the router. User can use the automatic or manual date and settings depending upon his choice.</p> <p style="text-align: center;"> <input type="button" value="Save Settings"/> <input type="button" value="Don't Save Settings"/> </p> </div>																														
System																															
Firmware																															
Firmware via USB																															
Dynamic DNS	<div style="border: 1px solid black; padding: 5px;"> <p><b>Logs Facility</b></p> <p>Facility: <input type="text" value="System"/> <input type="button" value="Display"/></p> </div>																														
System Check																															
Schedules																															
Set Language	<div style="border: 1px solid black; padding: 5px;"> <p><b>Display and Send Logs</b></p> <table style="width: 100%; border-collapse: collapse;"> <thead> <tr> <th style="width: 40%;"></th> <th style="width: 30%; text-align: center;">Display in Event Log</th> <th style="width: 30%; text-align: center;">Send to Syslog</th> </tr> </thead> <tbody> <tr> <td><b>Emergency:</b></td> <td style="text-align: center;"><input type="checkbox"/></td> <td style="text-align: center;"><input checked="" type="checkbox"/></td> </tr> <tr> <td><b>Alert:</b></td> <td style="text-align: center;"><input checked="" type="checkbox"/></td> <td style="text-align: center;"><input checked="" type="checkbox"/></td> </tr> <tr> <td><b>Critical:</b></td> <td style="text-align: center;"><input checked="" type="checkbox"/></td> <td style="text-align: center;"><input checked="" type="checkbox"/></td> </tr> <tr> <td><b>Error:</b></td> <td style="text-align: center;"><input checked="" type="checkbox"/></td> <td style="text-align: center;"><input checked="" type="checkbox"/></td> </tr> <tr> <td><b>Warning:</b></td> <td style="text-align: center;"><input checked="" type="checkbox"/></td> <td style="text-align: center;"><input type="checkbox"/></td> </tr> <tr> <td><b>Notification:</b></td> <td style="text-align: center;"><input type="checkbox"/></td> <td style="text-align: center;"><input type="checkbox"/></td> </tr> <tr> <td><b>Information:</b></td> <td style="text-align: center;"><input type="checkbox"/></td> <td style="text-align: center;"><input type="checkbox"/></td> </tr> <tr> <td><b>Debugging:</b></td> <td style="text-align: center;"><input type="checkbox"/></td> <td style="text-align: center;"><input type="checkbox"/></td> </tr> </tbody> </table> </div>					Display in Event Log	Send to Syslog	<b>Emergency:</b>	<input type="checkbox"/>	<input checked="" type="checkbox"/>	<b>Alert:</b>	<input checked="" type="checkbox"/>	<input checked="" type="checkbox"/>	<b>Critical:</b>	<input checked="" type="checkbox"/>	<input checked="" type="checkbox"/>	<b>Error:</b>	<input checked="" type="checkbox"/>	<input checked="" type="checkbox"/>	<b>Warning:</b>	<input checked="" type="checkbox"/>	<input type="checkbox"/>	<b>Notification:</b>	<input type="checkbox"/>	<input type="checkbox"/>	<b>Information:</b>	<input type="checkbox"/>	<input type="checkbox"/>	<b>Debugging:</b>	<input type="checkbox"/>	<input type="checkbox"/>
	Display in Event Log	Send to Syslog																													
<b>Emergency:</b>	<input type="checkbox"/>	<input checked="" type="checkbox"/>																													
<b>Alert:</b>	<input checked="" type="checkbox"/>	<input checked="" type="checkbox"/>																													
<b>Critical:</b>	<input checked="" type="checkbox"/>	<input checked="" type="checkbox"/>																													
<b>Error:</b>	<input checked="" type="checkbox"/>	<input checked="" type="checkbox"/>																													
<b>Warning:</b>	<input checked="" type="checkbox"/>	<input type="checkbox"/>																													
<b>Notification:</b>	<input type="checkbox"/>	<input type="checkbox"/>																													
<b>Information:</b>	<input type="checkbox"/>	<input type="checkbox"/>																													
<b>Debugging:</b>	<input type="checkbox"/>	<input type="checkbox"/>																													

The display for logging can be customized based on where the logs are sent, either the Event Log viewer in the GUI (the Event Log viewer is in the *Status > Logs* page) or a remote Syslog server for later review. E-mail logs, discussed in a subsequent section, follow the same configuration as logs configured for a Syslog server.

***Tools > Log Settings > Logs Configuration***

This page allows you to determine the type of traffic through the router that is logged for display in Syslog, E-mailed logs, or the Event Viewer. Denial of service attacks, general attack information, login attempts, dropped packets, and similar events can be captured for review by the IT administrator.

Traffic through each network segment (LAN, WAN, DMZ) can be tracked based on whether the packet was accepted or dropped by the firewall.

Accepted Packets are those that were successfully transferred through the corresponding network segment (i.e. LAN to WAN). This option is particularly useful when the Default Outbound Policy is “Block Always” so the IT admin can monitor traffic that is passed through the firewall.

- Example: If Accept Packets from LAN to WAN is enabled and there is a firewall rule to allow SSH traffic from LAN, then whenever a LAN machine

tries to make an SSH connection, those packets will be accepted and a message will be logged. (Assuming the log option is set to Allow for the SSH firewall rule.)

Dropped Packets are packets that were intentionally blocked from being transferred through the corresponding network segment. This option is useful when the Default Outbound Policy is “Allow Always”.

- Example: If Drop Packets from LAN to WAN is enabled and there is a firewall rule to block SSH traffic from LAN, then whenever a LAN machine tries to make an SSH connection, those packets will be dropped and a message will be logged. (Make sure the log option is set to allow for this firewall rule.)

 Enabling accepted packet logging through the firewall may generate a significant volume of log messages depending on the typical network traffic. This is recommended for debugging purposes only.

In addition to network segment logging, unicast and multicast traffic can be logged. Unicast packets have a single destination on the network, whereas broadcast (or multicast) packets are sent to all possible destinations simultaneously. One other useful log control is to log packets that are dropped due to configured bandwidth profiles over a particular interface. This data will indicate to the admin whether the bandwidth profile has to be modified to account for the desired internet traffic of LAN users.

Figure 114: Log configuration options for traffic through router

<b>DSR-1000N</b> //	<b>SETUP</b>	<b>ADVANCED</b>	<b>TOOLS</b>	<b>STATUS</b>																																				
Admin	<div style="border: 1px solid black; padding: 5px;"> <p><b>LOGS CONFIGURATION</b> <span style="float: right;">LOGOUT</span></p> <p>This page allows user to configure system wide log settings.</p> <p style="text-align: center;"> <input type="button" value="Save Settings"/> <input type="button" value="Don't Save Settings"/> </p> <p><b>Routing Logs</b></p> <table border="1" style="width: 100%; border-collapse: collapse;"> <thead> <tr> <th></th> <th style="text-align: center;">Accepted Packets</th> <th style="text-align: center;">Dropped Packets</th> </tr> </thead> <tbody> <tr> <td><b>LAN to WAN:</b></td> <td style="text-align: center;"><input checked="" type="checkbox"/></td> <td style="text-align: center;"><input checked="" type="checkbox"/></td> </tr> <tr> <td><b>WAN to LAN:</b></td> <td style="text-align: center;"><input checked="" type="checkbox"/></td> <td style="text-align: center;"><input checked="" type="checkbox"/></td> </tr> <tr> <td><b>WAN to DMZ:</b></td> <td style="text-align: center;"><input checked="" type="checkbox"/></td> <td style="text-align: center;"><input checked="" type="checkbox"/></td> </tr> <tr> <td><b>DMZ to WAN:</b></td> <td style="text-align: center;"><input type="checkbox"/></td> <td style="text-align: center;"><input checked="" type="checkbox"/></td> </tr> <tr> <td><b>LAN to DMZ:</b></td> <td style="text-align: center;"><input checked="" type="checkbox"/></td> <td style="text-align: center;"><input checked="" type="checkbox"/></td> </tr> <tr> <td><b>DMZ to LAN:</b></td> <td style="text-align: center;"><input type="checkbox"/></td> <td style="text-align: center;"><input type="checkbox"/></td> </tr> <tr> <td><b>VLAN to VLAN:</b></td> <td style="text-align: center;"><input checked="" type="checkbox"/></td> <td style="text-align: center;"><input type="checkbox"/></td> </tr> </tbody> </table> <p><b>System Logs</b></p> <table border="1" style="width: 100%; border-collapse: collapse;"> <tbody> <tr> <td><b>All Unicast Traffic:</b></td> <td style="text-align: center;"><input checked="" type="checkbox"/></td> </tr> <tr> <td><b>All Broadcast / Multicast Traffic:</b></td> <td style="text-align: center;"><input checked="" type="checkbox"/></td> </tr> <tr> <td><b>FTP Logs:</b></td> <td style="text-align: center;"><input checked="" type="checkbox"/></td> </tr> <tr> <td><b>Redirected ICMP Packets:</b></td> <td style="text-align: center;"><input checked="" type="checkbox"/></td> </tr> <tr> <td><b>Invalid Packets:</b></td> <td style="text-align: center;"><input type="checkbox"/></td> </tr> </tbody> </table> <p><b>Other Events Logs</b></p> <table border="1" style="width: 100%; border-collapse: collapse;"> <tbody> <tr> <td><b>Bandwidth Limit:</b></td> <td style="text-align: center;"><input checked="" type="checkbox"/></td> </tr> </tbody> </table> </div>					Accepted Packets	Dropped Packets	<b>LAN to WAN:</b>	<input checked="" type="checkbox"/>	<input checked="" type="checkbox"/>	<b>WAN to LAN:</b>	<input checked="" type="checkbox"/>	<input checked="" type="checkbox"/>	<b>WAN to DMZ:</b>	<input checked="" type="checkbox"/>	<input checked="" type="checkbox"/>	<b>DMZ to WAN:</b>	<input type="checkbox"/>	<input checked="" type="checkbox"/>	<b>LAN to DMZ:</b>	<input checked="" type="checkbox"/>	<input checked="" type="checkbox"/>	<b>DMZ to LAN:</b>	<input type="checkbox"/>	<input type="checkbox"/>	<b>VLAN to VLAN:</b>	<input checked="" type="checkbox"/>	<input type="checkbox"/>	<b>All Unicast Traffic:</b>	<input checked="" type="checkbox"/>	<b>All Broadcast / Multicast Traffic:</b>	<input checked="" type="checkbox"/>	<b>FTP Logs:</b>	<input checked="" type="checkbox"/>	<b>Redirected ICMP Packets:</b>	<input checked="" type="checkbox"/>	<b>Invalid Packets:</b>	<input type="checkbox"/>	<b>Bandwidth Limit:</b>	<input checked="" type="checkbox"/>
					Accepted Packets	Dropped Packets																																		
<b>LAN to WAN:</b>					<input checked="" type="checkbox"/>	<input checked="" type="checkbox"/>																																		
<b>WAN to LAN:</b>					<input checked="" type="checkbox"/>	<input checked="" type="checkbox"/>																																		
<b>WAN to DMZ:</b>					<input checked="" type="checkbox"/>	<input checked="" type="checkbox"/>																																		
<b>DMZ to WAN:</b>					<input type="checkbox"/>	<input checked="" type="checkbox"/>																																		
<b>LAN to DMZ:</b>					<input checked="" type="checkbox"/>	<input checked="" type="checkbox"/>																																		
<b>DMZ to LAN:</b>					<input type="checkbox"/>	<input type="checkbox"/>																																		
<b>VLAN to VLAN:</b>					<input checked="" type="checkbox"/>	<input type="checkbox"/>																																		
<b>All Unicast Traffic:</b>					<input checked="" type="checkbox"/>																																			
<b>All Broadcast / Multicast Traffic:</b>	<input checked="" type="checkbox"/>																																							
<b>FTP Logs:</b>	<input checked="" type="checkbox"/>																																							
<b>Redirected ICMP Packets:</b>	<input checked="" type="checkbox"/>																																							
<b>Invalid Packets:</b>	<input type="checkbox"/>																																							
<b>Bandwidth Limit:</b>	<input checked="" type="checkbox"/>																																							
Date and Time																																								
Log Settings																																								
System																																								
Firmware																																								
Firmware via USB																																								
Dynamic DNS																																								
System Check																																								
Schedules																																								
Set Language																																								

*Tools > Log Settings > IPv6 logging*

This page allows you to configure the IPv6 logging



**Figure 115: IPv6 Log configuration options for traffic through router**

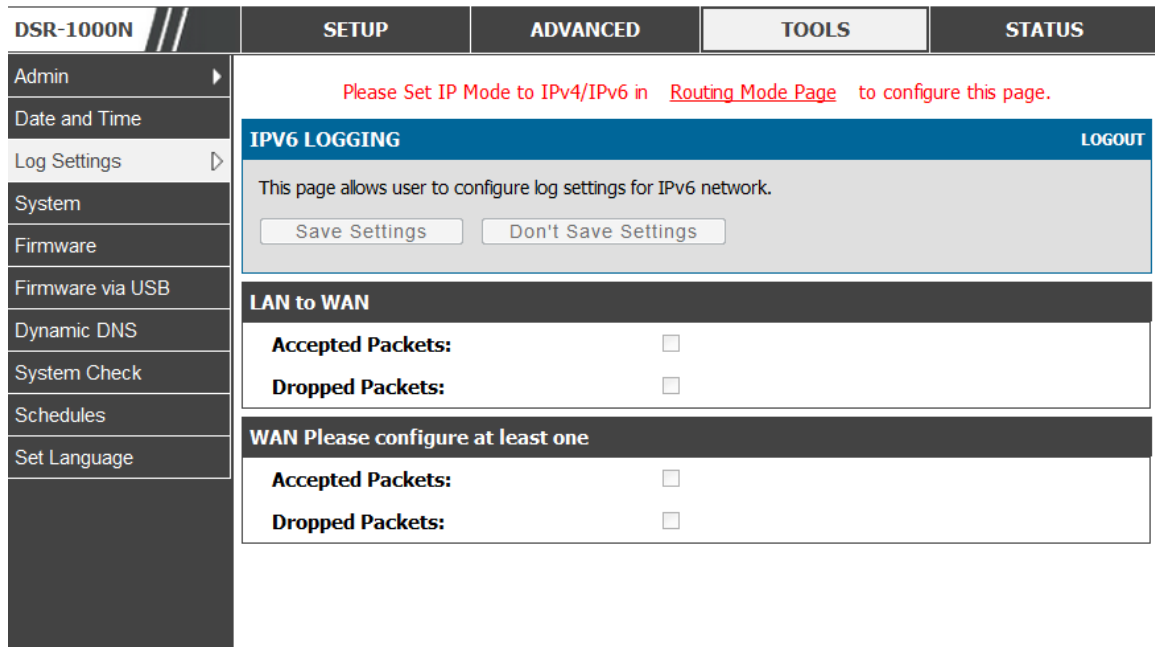

## 9.4.2 Sending Logs to E-mail or Syslog

### *Tools > Log Settings > Remote Logging*

Once you have configured the type of logs that you want the router to collect, they can be sent to either a Syslog server or an E-Mail address. For remote logging a key configuration field is the Remote Log Identifier. Every logged message will contain the configured prefix of the Remote Log Identifier, so that syslog servers or email addresses that receive logs from more than one router can sort for the relevant device’s logs.

Once you enable the option to e-mail logs, enter the e-mail server’s address (IP address or FQDN) of the SMTP server. The router will connect to this server when sending e-mails out to the configured addresses. The SMTP port and return e-mail addresses are required fields to allow the router to package the logs and send a valid e-mail that is accepted by one of the configured “send-to” addresses. Up to three e-mail addresses can be configured as log recipients.

In order to establish a connection with the configured SMTP port and server, define the server’s authentication requirements. The router supports Login Plain (no encryption) or CRAM-MD5 (encrypted) for the username and password data to be sent to the SMTP server. Authentication can be disabled if the server does not have this requirement. In some cases the SMTP server may send out IDENT requests, and this router can have this response option enabled as needed.

Once the e-mail server and recipient details are defined you can determine when the router should send out logs. E-mail logs can be sent out based on a defined schedule by first choosing the unit (i.e. the frequency) of sending logs: Hourly, Daily, or Weekly. Selecting Never will disable log e-mails but will preserve the e-mail server settings.

Figure 116: E-mail configuration as a Remote Logging option

DSR-1000N	SETUP	ADVANCED	TOOLS	STATUS
-----------	-------	----------	-------	--------

<ul style="list-style-type: none"> <li>Admin</li> <li>Date and Time</li> <li>Log Settings</li> <li>System</li> <li>Firmware</li> <li>Firmware via USB</li> <li>Dynamic DNS</li> <li>System Check</li> <li>Schedules</li> <li>Set Language</li> </ul>	<div style="background-color: #0070C0; color: white; padding: 2px; text-align: center;"><b>REMOTE LOGGING CONFIGURATION</b></div> <div style="text-align: right; font-size: small; color: #0070C0;">LOGOUT</div> <p style="font-size: x-small; color: #666;">This page allows user to configure the remote logging options for the router.</p> <p style="text-align: center;"> <input type="button" value="Save Settings"/> <input type="button" value="Don't Save Settings"/> </p> <hr/> <div style="background-color: #333; color: white; padding: 2px;"><b>Log Options</b></div> <p><b>Remote Log Identifier:</b> <input type="text" value="DSR-1000N"/></p> <hr/> <div style="background-color: #333; color: white; padding: 2px;"><b>Enable E-Mail Logs</b></div> <p><b>Enable E-Mail Logs:</b> <input type="checkbox"/></p> <p><b>E-Mail Server Address:</b> <input type="text"/></p> <p><b>SMTP Port:</b> <input type="text" value="25"/></p> <p><b>Return E-Mail Address:</b> <input type="text"/></p> <p><b>Send to E-Mail Address(1):</b> <input type="text"/></p> <p><b>Send to E-Mail Address(2):</b> <input type="text"/> (Optional)</p> <p><b>Send to E-Mail Address(3):</b> <input type="text"/> (Optional)</p> <p><b>Authentication with SMTP Server:</b> <input type="text" value="None"/></p> <p><b>User Name:</b> <input type="text"/></p> <p><b>Password:</b> <input type="text"/></p> <p><b>Respond to Identd from SMTP Server:</b> <input type="checkbox"/></p> <hr/> <div style="background-color: #333; color: white; padding: 2px;"><b>Send E-mail logs by Schedule</b></div> <p><b>Unit:</b> <input type="text" value="Never"/></p> <p><b>Day:</b> <input type="text" value="Sunday"/></p> <p><b>Time:</b> <input type="text" value="1:00"/> <input checked="" type="radio"/> (AM) <input type="radio"/> (PM)</p> <hr/> <div style="background-color: #333; color: white; padding: 2px;"><b>SYS LOG SERVER CONFIGURATION</b></div> <table border="1" style="width: 100%; border-collapse: collapse; font-size: x-small;"> <thead> <tr> <th style="width: 5%;"></th> <th style="width: 20%;">Name</th> <th style="width: 30%;">SysLog Facility</th> <th style="width: 45%;">SysLog Severity</th> </tr> </thead> <tbody> <tr> <td style="text-align: center;"><input type="checkbox"/></td> <td>SysLog Server1:</td> <td><input type="text" value="All"/></td> <td><input type="text" value="All"/></td> </tr> </tbody> </table>		Name	SysLog Facility	SysLog Severity	<input type="checkbox"/>	SysLog Server1:	<input type="text" value="All"/>	<input type="text" value="All"/>
	Name	SysLog Facility	SysLog Severity						
<input type="checkbox"/>	SysLog Server1:	<input type="text" value="All"/>	<input type="text" value="All"/>						

An external Syslog server is often used by network administrator to collect and store logs from the router. This remote device typically has less memory constraints than the local Event Viewer on the router’s GUI, and thus can collect a considerable number of logs over a sustained period. This is typically very useful for debugging network issues or to monitor router traffic over a long duration.

This router supports up to 8 concurrent Syslog servers. Each can be configured to receive different log facility messages of varying severity. To enable a Syslog server select the checkbox next to an empty Syslog server field and assign the IP address or FQDN to the Name field. The selected facility and severity level messages will be

sent to the configured (and enabled) Syslog server once you save this configuration page's settings.

**Figure 117: Syslog server configuration for Remote Logging (continued)**

SYS LOG SERVER CONFIGURATION				
		Name	SysLog Facility	SysLog Severity
<input type="checkbox"/>	SysLog Server1:	<input type="text"/>	All	All
<input type="checkbox"/>	SysLog Server2:	<input type="text"/>	All	All
<input type="checkbox"/>	SysLog Server3:	<input type="text"/>	All	All
<input type="checkbox"/>	SysLog Server4:	<input type="text"/>	All	All
<input type="checkbox"/>	SysLog Server5:	<input type="text"/>	All	All
<input type="checkbox"/>	SysLog Server6:	<input type="text"/>	All	All
<input type="checkbox"/>	SysLog Server7:	<input type="text"/>	All	All
<input type="checkbox"/>	SysLog Server8:	<input type="text"/>	All	All

### 9.4.3 Event Log Viewer in GUI

*Status > Logs > View All Logs*

The router GUI lets you observe configured log messages from the Status menu. Whenever traffic through or to the router matches the settings determined in the *Tools > Log Settings > Logs Facility* or *Tools > Log Settings > Logs Configuration* pages, the corresponding log message will be displayed in this window with a timestamp.

 It is very important to have accurate system time (manually set or from a NTP server) in order to understand log messages.

*Status > Logs > VPN Logs*

This page displays IPsec VPN log messages as determined by the configuration settings for facility and severity. This data is useful when evaluating IPsec VPN traffic and tunnel health.

Figure 118: VPN logs displayed in GUI event viewer

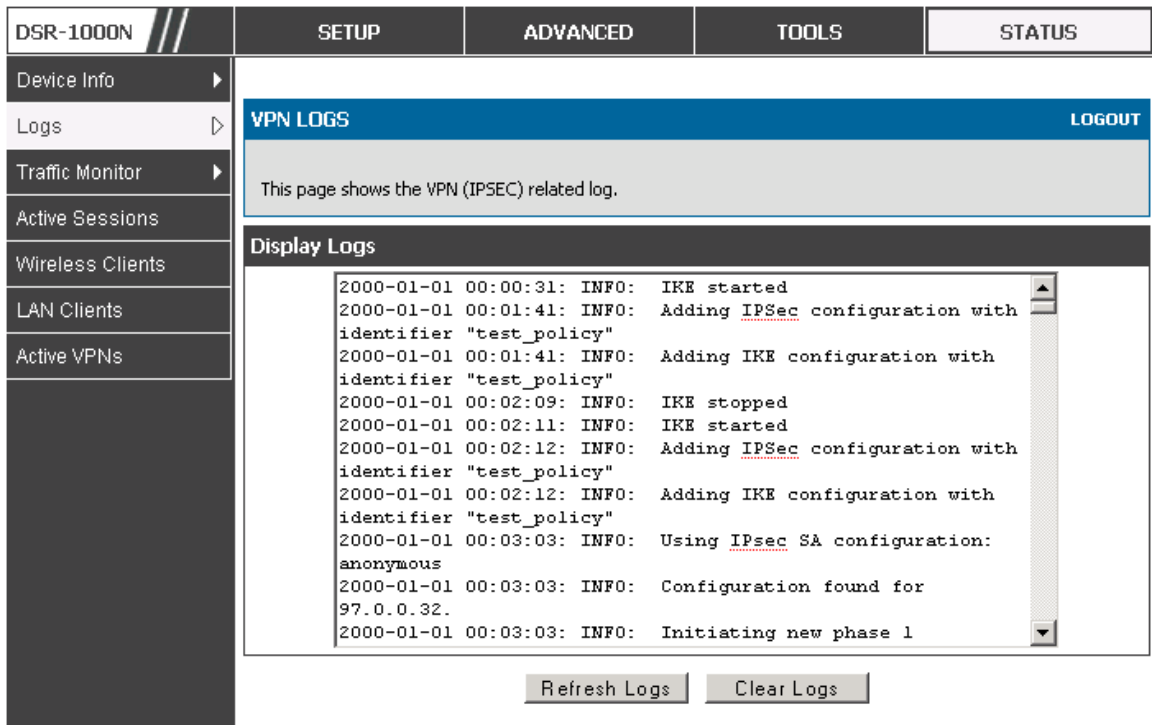

## 9.5 Backing up and Restoring Configuration Settings

### *Tools > System*

You can back up the router’s custom configuration settings to restore them to a different device or the same router after some other changes. During backup, your settings are saved as a file on your host. You can restore the router's saved settings from this file as well. This page will also allow you revert to factory default settings or execute a soft reboot of the router.

**IMPORTANT!** During a restore operation, do NOT try to go online, turn off the router, shut down the PC, or do anything else to the router until the operation is complete. This will take approximately 1 minute. Once the LEDs are turned off, wait a few more seconds before doing anything with the router.

For backing up configuration or restoring a previously saved configuration, please follow the steps below:

1. To save a copy of your current settings, click the Backup button in the Save Current Settings option. The browser initiates an export of the configuration file and prompts to save the file on your host.

2. To restore your saved settings from a backup file, click **Browse** then locate the file on the host. After clicking **Restore**, the router begins importing the file's saved configuration settings. After the restore, the router reboots automatically with the restored settings.
3. To erase your current settings and revert to factory default settings, click the **Default** button. The router will then restore configuration settings to factory defaults and will reboot automatically. (See Appendix B for the factory default parameters for the router).

**Figure 119: Restoring configuration from a saved file will result in the current configuration being overwritten and a reboot**

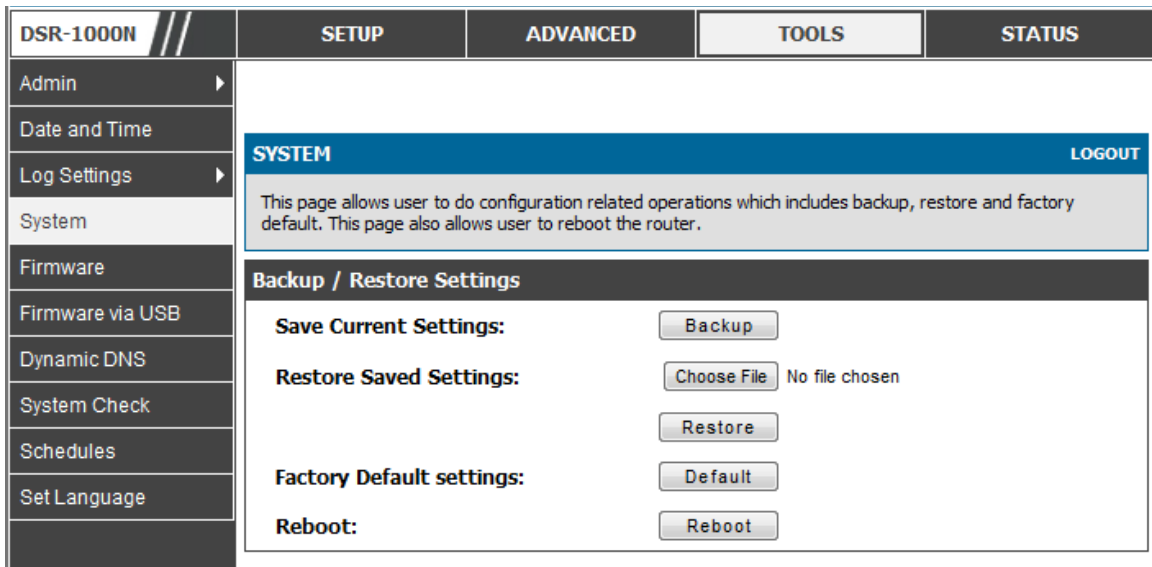

## 9.6 Upgrading Router Firmware

### *Tools > Firmware*

You can upgrade to a newer software version from the Administration web page. In the Firmware Upgrade section, to upgrade your firmware, click **Browse**, locate and select the firmware image on your host, and click **Upgrade**. After the new firmware image is validated, the new image is written to flash, and the router is automatically rebooted with the new firmware. The Firmware Information and also the **Status > Device Info > Device Status** page will reflect the new firmware version.

 **IMPORTANT!** During firmware upgrade, do NOT try to go online, turn off the DSR, shut down the PC, or interrupt the process in anyway until the operation is complete. This should take only a minute or so including the reboot process. Interrupting the upgrade process at specific points when the flash is being written to may corrupt the flash memory and render the router unusable without a low-level process of restoring the flash firmware (not through the web GUI).

**Figure 120: Firmware version information and upgrade option**

DSR-1000N	SETUP	ADVANCED	TOOLS	STATUS
Admin				
Date and Time				
Log Settings	<b>FIRMWARE</b> <span style="float: right;">LOGOUT</span>			
System	This page allows user to upgrade/downgrade the router firmware. This page also shows the information regarding firmware version and build time.			
Firmware	<b>Firmware Information</b>			
Firmware via USB	<b>Firmware Version:</b> 1.06B04_WW <b>Firmware Date:</b> Tue Jan 31 12:33:59 2012			
Dynamic DNS	<b>Firmware Upgrade</b>			
System Check	<b>Locate &amp; select the upgrade file:</b> <input type="button" value="Choose File"/> No file chosen <input type="button" value="Upgrade"/>			
Schedules	<b>Firmware Upgrade Notification Options</b>			
Set Language	<b>Check Now:</b> <input type="button" value="Check Now"/> <b>Status:</b>			

This router also supports an automated notification to determine if a newer firmware version is available for this router. By clicking the Check Now button in the notification section, the router will check a D-Link server to see if a newer firmware version for this router is available for download and update the Status field below.

**IMPORTANT!** After firmware 1.04B13, new user database architecture is introduced. The new user database is easier to setup and more intuitively to use. When users upgrade DSR’s firmware to 1.04B13 or latter, DSR will automatically merge users in the old database into the new one. However, all user databases will be swept away when users downgrade firmware from 1.04B13 to the older one, e.g. 1.03B43. Please keep in mind: backup your user database for further restoring once you decide to downgrade firmware to the older one.

## 9.7 Upgrading Router Firmware via USB

### *Tools > Firmware via USB*

This page allows user to upgrade the firmware, backup and restore the settings using a USB storage key.

Figure 121: Firmware upgrade and configuration restore/backup via USB

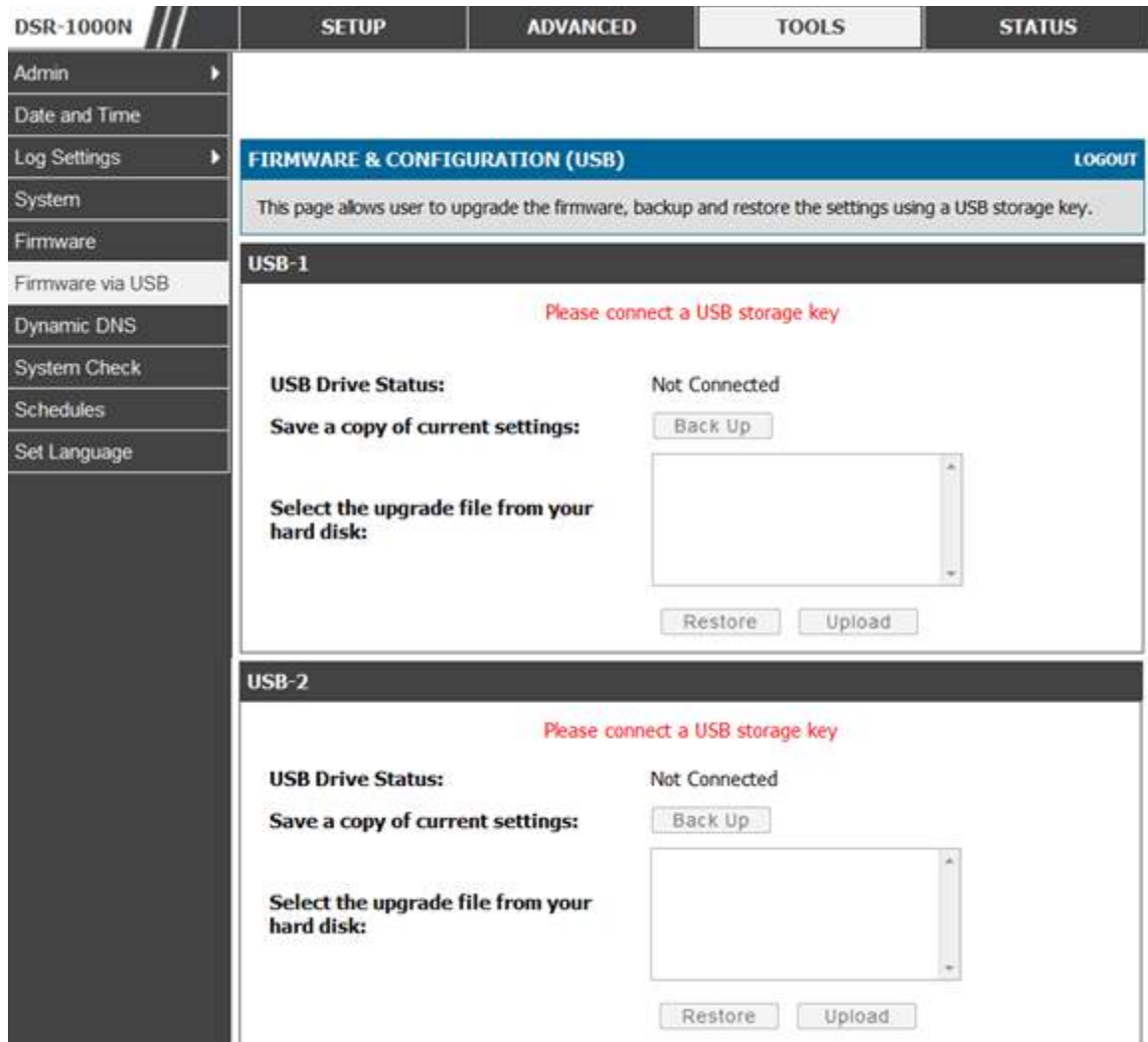

## 9.8 Dynamic DNS Setup

### *Tools > Dynamic DNS*

Dynamic DNS (DDNS) is an Internet service that allows routers with varying public IP addresses to be located using Internet domain names. To use DDNS, you must setup an account with a DDNS provider such as DynDNS.org, D-Link DDNS, or Oray.net.

Each configured WAN can have a different DDNS service if required. Once configured, the router will update DDNS services changes in the WAN IP address so that features that are dependent on accessing the router's WAN via FQDN will be directed to the correct IP address. When you set up an account with a DDNS service, the host and domain name, username, password and wildcard support will be provided by the account provider.

Figure 122: Dynamic DNS configuration

DSR-1000N	SETUP	ADVANCED	TOOLS	STATUS
Admin	<div style="border: 1px solid black; padding: 5px;"> <p><b>DYNAMIC DNS</b> <span style="float: right;">LOGOUT</span></p> <p>Dynamic DNS (DDNS) is an Internet service that allows routers with varying public IP addresses to be located using Internet domain names. To use DDNS, you must setup an account with a DDNS provider such as DynDNS.com, DlinkDDNS.com or Oray.net.</p> <p style="text-align: center;"> <input type="button" value="Save Settings"/> <input type="button" value="Don't Save Settings"/> </p> </div>			
Date and Time				
Log Settings				
System				
Firmware				
Firmware via USB				
Dynamic DNS				
System Check				
Schedules				
Set Language				
<div style="border: 1px solid black; padding: 5px;"> <p><b>WAN Mode</b></p> <p><b>Current WAN Mode:</b> Use only single WAN portDedicated WAN</p> </div>				
<div style="border: 1px solid black; padding: 5px;"> <p><b>Dedicated WAN (DDNS Status: )</b></p> <p><b>Select the Dynamic DNS Service:</b> <input type="text" value="None"/></p> <p><b>Host and Domain Name:</b> <input type="text"/></p> <p><b>User Name:</b> <input type="text"/></p> <p><b>Password:</b> <input type="text"/></p> <p><b>Use wildcards:</b> <input type="checkbox"/></p> <p><b>Update every 30 days:</b> <input type="checkbox"/></p> </div>				
<div style="border: 1px solid black; padding: 5px;"> <p><b>Configurable WAN</b></p> <p><b>Select the Dynamic DNS Service:</b> <input type="text" value="None"/></p> <p><b>Host and Domain Name:</b> <input type="text"/></p> <p><b>User Name:</b> <input type="text"/></p> <p><b>Password:</b> <input type="text"/></p> </div>				

## 9.9 Using Diagnostic Tools

### *Tools > System Check*

The router has built in tools to allow an administrator to evaluate the communication status and overall network health.



**Figure 123: Router diagnostics tools available in the GUI**

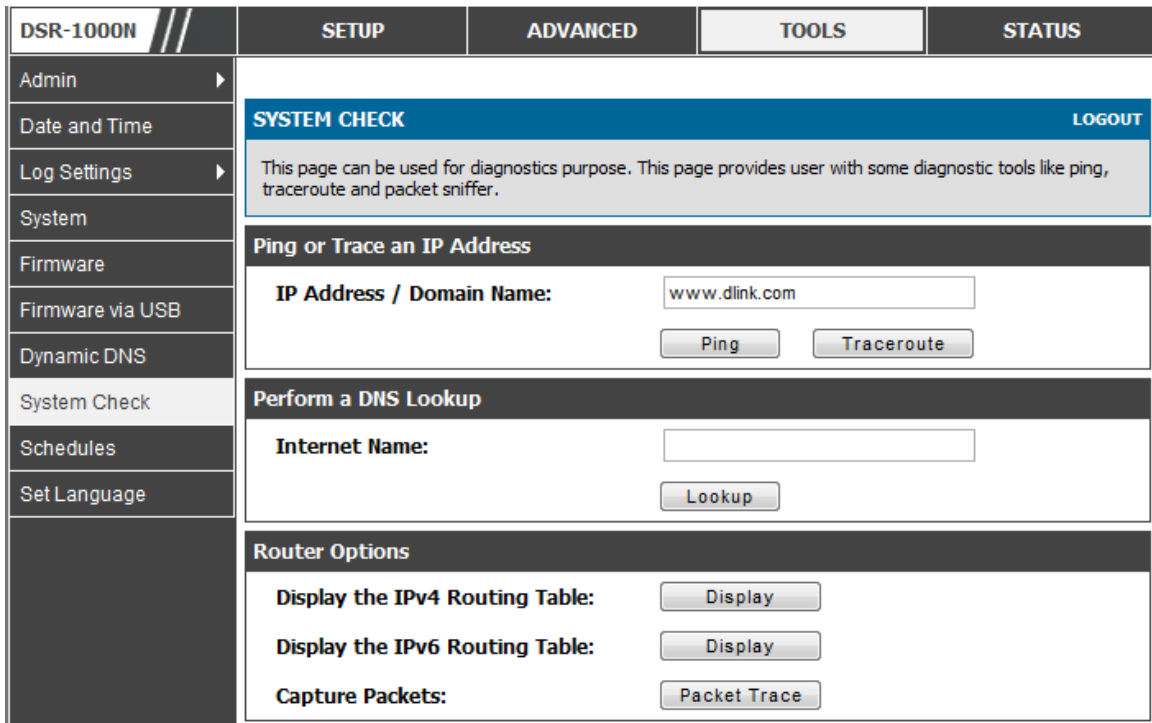

## 9.9.1 Ping

This utility can be used to test connectivity between this router and another device on the network connected to this router. Enter an IP address and click PING. The command output will appear indicating the ICMP echo request status.

## 9.9.2 Trace Route

This utility will display all the routers present between the destination IP address and this router. Up to 30 “hops” (intermediate routers) between this router and the destination will be displayed.

Figure 124: Sample trace route output

Trace Route To www.dlink.com...

**SYSTEM CHECK** LOGOUT

This page displays the output of the diagnostic command which user runs.

**Command Output**

```

Kernel IP routing table
Destination      Gateway         Genmask         Flags Metric Ref    Use Iface
127.0.0.1        127.0.0.1      255.255.255.255 UGH    1     0     0     lo
192.168.2.0      *               255.255.255.0   U      0     0     0     bdg22
192.168.2.0      192.168.2.1    255.255.255.0   UG     1     0     0     bdg22
192.168.75.0     *               255.255.255.0   U      0     0     0     eth1
192.168.75.0     192.168.75.100 255.255.255.0   UG     1     0     0     eth1
97.0.0.0         *               255.0.0.0       U      0     0     0     bdg1
97.0.0.0         97.0.0.2       255.0.0.0       UG     1     0     0     bdg1
default          192.168.75.4   0.0.0.0         UG     0     0     0     eth1
                    
```

[Back...](#)

### 9.9.3 DNS Lookup

To retrieve the IP address of a Web, FTP, Mail or any other server on the Internet, type the Internet Name in the text box and click Lookup. If the host or domain entry exists, you will see a response with the IP address. A message stating “Unknown Host” indicates that the specified Internet Name does not exist.

This feature assumes there is internet access available on the WAN link(s).

### 9.9.4 Router Options

The static and dynamic routes configured on this router can be shown by clicking Display for the corresponding routing table. Clicking the Packet Trace button will allow the router to capture and display traffic through the DSR between the LAN and WAN interface as well. This information is often very useful in debugging traffic and routing issues.

## 9.10 Localization

### *Tools > Set Language*

The router has built in tools to allow change the default language (English) to four different languages . (French, Deutsche, Spanish and Italian)

**Figure 125: Localization**

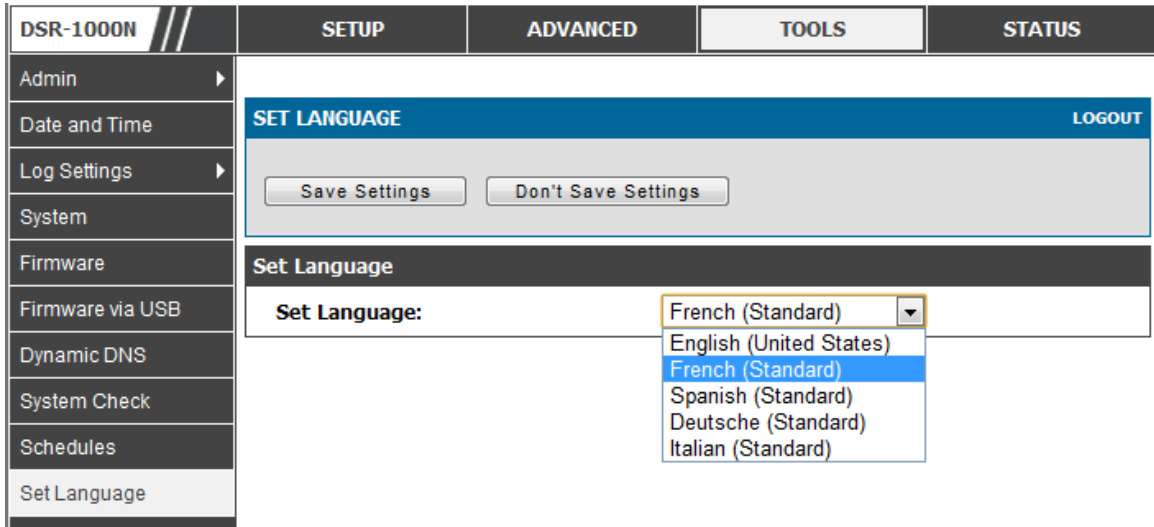

# Chapter 10. Router Status and Statistics

## 10.1 System Overview

The Status page allows you to get a detailed overview of the system configuration. The settings for the wired and wireless interfaces are displayed in the DSR Status page, and then the resulting hardware resource and router usage details are summarized on the router's Dashboard.

### 10.1.1 Device Status

#### *Status > Device Info > Device Status*

The DSR Status page gives a summary of the router configuration settings configured in the Setup and Advanced menus. The static hardware serial number and current firmware version are presented in the General section. The WAN and LAN interface information shown on this page are based on the administrator configuration parameters. The radio band and channel settings are presented below along with all configured and active APs that are enabled on this router.

**Figure 126: Device Status display**

DSR-1000N	SETUP	ADVANCED	TOOLS	STATUS
-----------	-------	----------	-------	--------

Device Info ▶ Logs ▶ Traffic Monitor ▶ Active Sessions Wireless Clients LAN Clients Active VPNs	<table border="1" style="width: 100%; border-collapse: collapse;"> <tr> <th colspan="2" style="background-color: #0070C0; color: white;">DEVICE STATUS</th> <th style="text-align: right; color: white;">LOGOUT</th> </tr> <tr> <td colspan="3" style="text-align: center; padding: 5px;">                     This page displays the current settings of the ports and displays a snapshot of the system information.                 </td> </tr> <tr> <th colspan="3" style="background-color: #333; color: white;">General</th> </tr> <tr> <td style="padding: 5px;"><b>System Name:</b></td> <td colspan="2" style="padding: 5px;">DSR_router</td> </tr> <tr> <td style="padding: 5px;"><b>Firmware Version:</b></td> <td colspan="2" style="padding: 5px;">1.01B18</td> </tr> <tr> <td style="padding: 5px;"><b>Serial Number:</b></td> <td colspan="2" style="padding: 5px;">00000000000001</td> </tr> <tr> <th colspan="3" style="background-color: #333; color: white;">WAN1 Information</th> </tr> <tr> <td style="padding: 5px;"><b>MAC Address:</b></td> <td colspan="2" style="padding: 5px;">00:DE:AD:20:75:01</td> </tr> <tr> <td style="padding: 5px;"><b>IPv4 Address:</b></td> <td colspan="2" style="padding: 5px;">0.0.0.0 / 0.0.0.0</td> </tr> <tr> <td style="padding: 5px;"><b>IPv6 Address:</b></td> <td colspan="2" style="padding: 5px;"></td> </tr> <tr> <td style="padding: 5px;"><b>Wan State:</b></td> <td colspan="2" style="padding: 5px;">DOWN</td> </tr> <tr> <td style="padding: 5px;"><b>NAT (IPv4 only):</b></td> <td colspan="2" style="padding: 5px;">Enabled</td> </tr> <tr> <td style="padding: 5px;"><b>IPv4 Connection Type:</b></td> <td colspan="2" style="padding: 5px;">Dynamic IP (DHCP)</td> </tr> <tr> <td style="padding: 5px;"><b>IPv6 Connection Type:</b></td> <td colspan="2" style="padding: 5px;">IPv6 is disabled</td> </tr> <tr> <td style="padding: 5px;"><b>IPv4 Connection State:</b></td> <td colspan="2" style="padding: 5px;">Not Yet Connected</td> </tr> <tr> <td style="padding: 5px;"><b>IPv6 Connection State:</b></td> <td colspan="2" style="padding: 5px;">IPv6 is disabled</td> </tr> <tr> <td style="padding: 5px;"><b>Link State:</b></td> <td colspan="2" style="padding: 5px;">LINK DOWN</td> </tr> <tr> <td style="padding: 5px;"><b>WAN Mode:</b></td> <td colspan="2" style="padding: 5px;">Use only single WAN port: Secondary WAN</td> </tr> <tr> <td style="padding: 5px;"><b>Gateway:</b></td> <td colspan="2" style="padding: 5px;">0.0.0.0</td> </tr> <tr> <td style="padding: 5px;"><b>Primary DNS:</b></td> <td colspan="2" style="padding: 5px;">0.0.0.0</td> </tr> <tr> <td style="padding: 5px;"><b>Secondary DNS:</b></td> <td colspan="2" style="padding: 5px;">0.0.0.0</td> </tr> </table>	DEVICE STATUS		LOGOUT	This page displays the current settings of the ports and displays a snapshot of the system information.			General			<b>System Name:</b>	DSR_router		<b>Firmware Version:</b>	1.01B18		<b>Serial Number:</b>	00000000000001		WAN1 Information			<b>MAC Address:</b>	00:DE:AD:20:75:01		<b>IPv4 Address:</b>	0.0.0.0 / 0.0.0.0		<b>IPv6 Address:</b>			<b>Wan State:</b>	DOWN		<b>NAT (IPv4 only):</b>	Enabled		<b>IPv4 Connection Type:</b>	Dynamic IP (DHCP)		<b>IPv6 Connection Type:</b>	IPv6 is disabled		<b>IPv4 Connection State:</b>	Not Yet Connected		<b>IPv6 Connection State:</b>	IPv6 is disabled		<b>Link State:</b>	LINK DOWN		<b>WAN Mode:</b>	Use only single WAN port: Secondary WAN		<b>Gateway:</b>	0.0.0.0		<b>Primary DNS:</b>	0.0.0.0		<b>Secondary DNS:</b>	0.0.0.0	
DEVICE STATUS		LOGOUT																																																														
This page displays the current settings of the ports and displays a snapshot of the system information.																																																																
General																																																																
<b>System Name:</b>	DSR_router																																																															
<b>Firmware Version:</b>	1.01B18																																																															
<b>Serial Number:</b>	00000000000001																																																															
WAN1 Information																																																																
<b>MAC Address:</b>	00:DE:AD:20:75:01																																																															
<b>IPv4 Address:</b>	0.0.0.0 / 0.0.0.0																																																															
<b>IPv6 Address:</b>																																																																
<b>Wan State:</b>	DOWN																																																															
<b>NAT (IPv4 only):</b>	Enabled																																																															
<b>IPv4 Connection Type:</b>	Dynamic IP (DHCP)																																																															
<b>IPv6 Connection Type:</b>	IPv6 is disabled																																																															
<b>IPv4 Connection State:</b>	Not Yet Connected																																																															
<b>IPv6 Connection State:</b>	IPv6 is disabled																																																															
<b>Link State:</b>	LINK DOWN																																																															
<b>WAN Mode:</b>	Use only single WAN port: Secondary WAN																																																															
<b>Gateway:</b>	0.0.0.0																																																															
<b>Primary DNS:</b>	0.0.0.0																																																															
<b>Secondary DNS:</b>	0.0.0.0																																																															

Figure 127: Device Status display (continued)

WAN2 Information			
<b>MAC Address:</b>	AA:BB:CC:DD:EF:01		
<b>IPv4 Address:</b>	0.0.0.0 / 0.0.0.0		
<b>IPv6 Address:</b>			
<b>Wan State:</b>	DOWN		
<b>NAT (IPv4 only):</b>	Enabled		
<b>IPv4 Connection Type:</b>	ThreeG		
<b>IPv6 Connection Type:</b>	IPv6 is disabled		
<b>IPv4 Connection State:</b>	Unable To Open Communication Port		
<b>IPv6 Connection State:</b>	IPv6 is disabled		
<b>Link State:</b>	LINK DOWN		
<b>WAN Mode:</b>	Use only single WAN port: Secondary WAN		
<b>Gateway:</b>	0.0.0.0		
<b>Primary DNS:</b>	0.0.0.0		
<b>Secondary DNS:</b>	0.0.0.0		
LAN Information			
<b>MAC Address:</b>	00:DE:AD:20:75:00		
<b>IP Address:</b>	176.16.2.40 / 255.255.255.0		
<b>IPv6 Address:</b>			
<b>DHCP Server:</b>	Disabled		
<b>DHCP Relay:</b>	Disabled		
<b>DHCPv6 Server:</b>	IPv6 is disabled		
Wireless LAN			
<b>Operating Frequency:</b>	2.4GHz		
<b>Mode:</b>	N/G-Mixed		
<b>Channel:</b>	Auto		
Available Access Points			
SSID	SECURITY	ENCRYPTION	AUTHENTICATION
admin	WPA+WPA2	TKIP+CCMP	PSK

## 10.1.2 Resource Utilization

### *Status > Device Info > Dashboard*

The Dashboard page presents hardware and usage statistics. The CPU and Memory utilization is a function of the available hardware and current configuration and traffic through the router. Interface statistics for the wired connections (LAN, WAN1, WAN2/DMZ, VLANs) provide indication of packets through and packets dropped by the interface. Click refresh to have this page retrieve the most current statistics.

Figure 128: Resource Utilization statistics

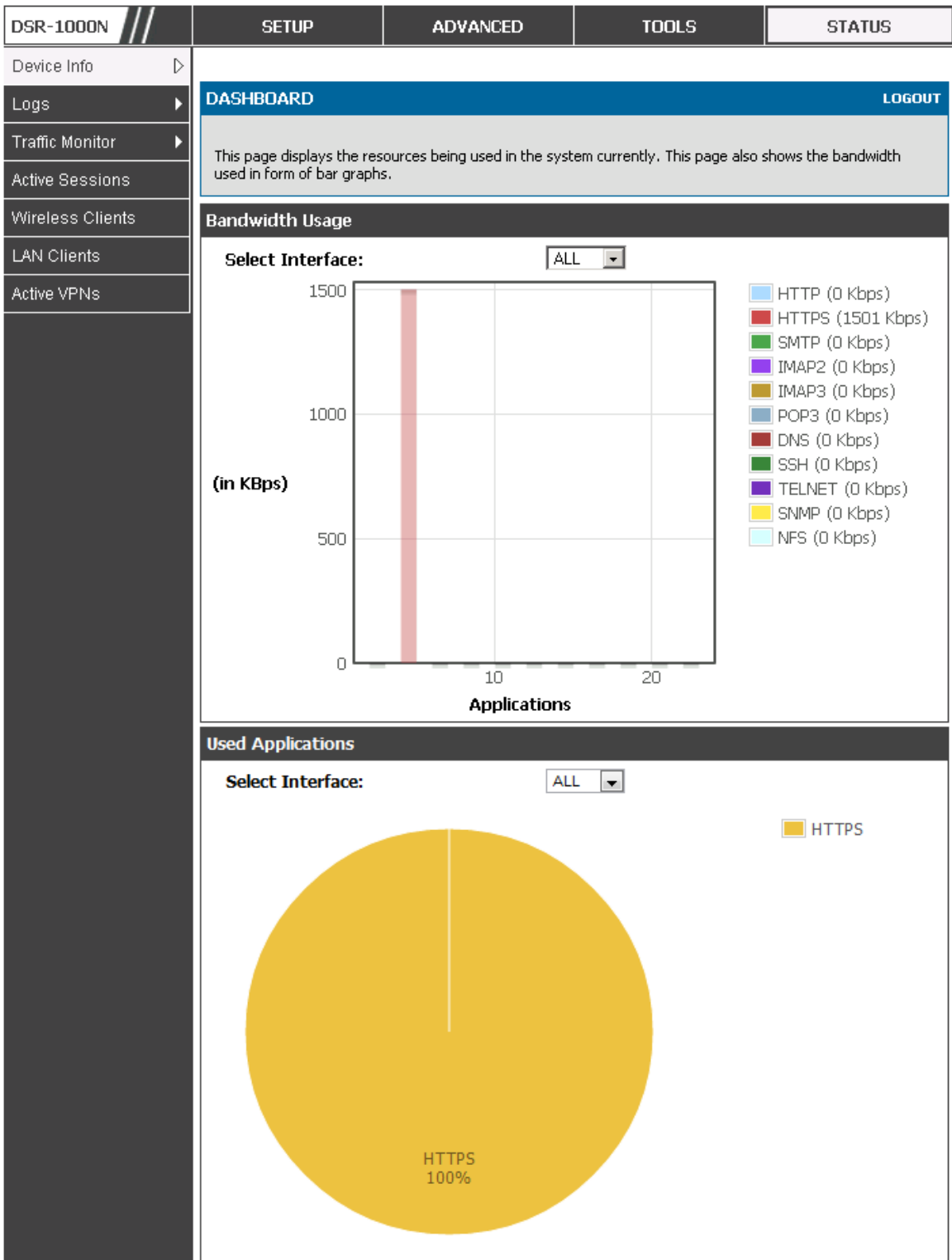

Figure 129: Resource Utilization data (continued)

CPU Utilization	
CPU usage by user:	27 %
CPU usage by kernel:	11 %
CPU idle:	62 %
CPU waiting for IO:	0 %
Memory Utilization	
Total Memory:	247908 KB
Used Memory:	172848 KB
Free Memory:	75060 KB
Cached Memory:	30840 KB
Buffer Memory:	7800 KB
Interface (LAN)	
Incoming Packets: :	49900
Outgoing Packets:	5259
Dropped In Packets:	0
Dropped Out Packets:	0
Interface (WAN1)	
Incoming Packets: :	0
Outgoing Packets:	8
Dropped In Packets:	0
Dropped Out Packets:	0
Interface (DMZ/WAN2)	
Incoming Packets:	0
Outgoing Packets:	10
Dropped In Packets:	0
Dropped Out Packets:	0



Figure 130: Resource Utilization data (continued)

Interface (VLAN)				
Port	Incoming Packets	Outgoing Packets	Dropped In Packets	Dropped Out Packets
LAN12	0	9	0	0
LAN15	0	9	0	0
LAN16	0	9	0	0

Active Info	
<b>ICMP Received:</b>	5
<b>Active VPN Tunnels:</b>	0
<b>Available VLANs:</b>	4
<b>Active Interfaces:</b>	8

## 10.2 Traffic Statistics

### 10.2.1 Wired Port Statistics

#### *Status > Traffic Monitor > Device Statistics*

Detailed transmit and receive statistics for each physical port are presented here. Each interface (WAN1, WAN2/DMZ, LAN, and VLANs) have port specific packet level information provided for review. Transmitted/received packets, port collisions, and the cumulating bytes/sec for transmit/receive directions are provided for each interface along with the port up time. If you suspect issues with any of the wired ports, this table will help diagnose uptime or transmit level issues with the port.

The statistics table has auto-refresh control which allows display of the most current port level data at each page refresh. The default auto-refresh for this page is 10 seconds.

**Figure 131: Physical port statistics**

The page will auto-refresh in 8 seconds

**DEVICE STATISTICS** LOGOUT

This page shows the Rx/Tx packet and byte count for all the system interfaces. It also shows the up time for all the interfaces.

**System up Time : 0 days, 1 hours, 11 minutes, 56 seconds**

Port Statistics						
Port	Tx Pkts	Rx Pkts	Collisions	Tx B/s	Rx B/s	Up time
Dedicated WAN	96	0	0	0	0	0 Days 01:10:22
Configurable Port (WAN)	8	0	0	0	0	0 Days 01:09:55
LAN	12014	10292	0	0	0	0 Days 01:09:55
LAN22				0	0	Not Yet Available

Poll Interval:  (Seconds)

## 10.2.2 Wireless Statistics

### *Status > Traffic Monitor > Wireless Statistics*

The Wireless Statistics tab displays the incrementing traffic statistics for each enabled access point. This page will give a snapshot of how much traffic is being transmitted over each wireless link. If you suspect that a radio or VAP may be down, the details on this page would confirm if traffic is being sent and received through the VAP.

The clients connected to a particular AP can be viewed by using the Status Button on the list of APs in the *Setup > Wireless > Access Points* page. Traffic statistics are shown for that individual AP, as compared to the summary stats for each AP on this Statistics page. The poll interval (the refresh rate for the statistics) can be modified to view more frequent traffic and collision statistics.

**Figure 132: AP specific statistics**

The page will auto-refresh in 1 seconds

**WIRELESS STATISTICS** LOGOUT

Wireless traffic statistics for all configured access points are displayed in this table. The receive (rx) and transmit (tx) data is shown per configured AP.

AP Name	Radio	Packets		Bytes		Errors		Dropped		Multicast	Collisions
		rx	tx	rx	tx	rx	tx	rx	tx		
ap1	1	0	0	0	0	0	0	0	173	0	0
Open_guests	1	0	0	0	0	0	0	0	127	0	0

Poll Interval:  (Seconds)

## 10.3 Active Connections

### 10.3.1 Sessions through the Router

*Status > Active Sessions*

This table lists the active internet sessions through the router’s firewall. The session’s protocol, state, local and remote IP addresses are shown.

**Figure 133: List of current Active Firewall Sessions**

DSR-1000N	SETUP	ADVANCED	TOOLS	STATUS																																																																																																																												
Device Info																																																																																																																																
Logs	<b>ACTIVE SESSIONS</b> <span style="float: right;">LOGOUT</span>																																																																																																																															
Traffic Monitor	This page displays a list of active sessions on your router.																																																																																																																															
Active Sessions	<table border="1"> <thead> <tr> <th colspan="4">Active Sessions</th> </tr> <tr> <th>Local</th> <th>Internet</th> <th>Protocol</th> <th>State</th> </tr> </thead> <tbody> <tr><td>97.0.0.5:3465</td><td>97.0.0.2:443</td><td>tcp</td><td>TIME_WAIT</td></tr> <tr><td>97.0.0.5:3525</td><td>97.0.0.2:443</td><td>tcp</td><td>TIME_WAIT</td></tr> <tr><td>97.0.0.5:3491</td><td>97.0.0.2:443</td><td>tcp</td><td>TIME_WAIT</td></tr> <tr><td>97.0.0.5:3459</td><td>97.0.0.2:443</td><td>tcp</td><td>TIME_WAIT</td></tr> <tr><td>97.0.0.5:3487</td><td>97.0.0.2:443</td><td>tcp</td><td>TIME_WAIT</td></tr> <tr><td>97.0.0.5:3408</td><td>97.0.0.2:443</td><td>tcp</td><td>TIME_WAIT</td></tr> <tr><td>97.0.0.5:3493</td><td>97.0.0.2:443</td><td>tcp</td><td>TIME_WAIT</td></tr> <tr><td>97.0.0.5:3431</td><td>97.0.0.2:443</td><td>tcp</td><td>TIME_WAIT</td></tr> <tr><td>97.0.0.5:3479</td><td>97.0.0.2:443</td><td>tcp</td><td>TIME_WAIT</td></tr> <tr><td>97.0.0.5:3515</td><td>97.0.0.2:443</td><td>tcp</td><td>TIME_WAIT</td></tr> <tr><td>97.0.0.5:3501</td><td>97.0.0.2:443</td><td>tcp</td><td>TIME_WAIT</td></tr> <tr><td>97.0.0.5:3527</td><td>97.0.0.2:443</td><td>tcp</td><td>CLOSE</td></tr> <tr><td>192.168.75.100:500</td><td>97.0.0.32:500</td><td>udp</td><td>none</td></tr> <tr><td>97.0.0.5:3427</td><td>97.0.0.2:443</td><td>tcp</td><td>TIME_WAIT</td></tr> <tr><td>97.0.0.5:3519</td><td>97.0.0.2:443</td><td>tcp</td><td>CLOSE</td></tr> <tr><td>97.0.0.5:3507</td><td>97.0.0.2:443</td><td>tcp</td><td>TIME_WAIT</td></tr> <tr><td>97.0.0.5:3543</td><td>97.0.0.2:443</td><td>tcp</td><td>CLOSE</td></tr> <tr><td>97.0.0.5:3437</td><td>97.0.0.2:443</td><td>tcp</td><td>TIME_WAIT</td></tr> <tr><td>97.0.0.5:3409</td><td>97.0.0.2:443</td><td>tcp</td><td>TIME_WAIT</td></tr> <tr><td>97.0.0.5:3497</td><td>97.0.0.2:443</td><td>tcp</td><td>TIME_WAIT</td></tr> <tr><td>97.0.0.5:3541</td><td>97.0.0.2:443</td><td>tcp</td><td>TIME_WAIT</td></tr> <tr><td>97.0.0.5:3489</td><td>97.0.0.2:443</td><td>tcp</td><td>TIME_WAIT</td></tr> <tr><td>97.0.0.5:3482</td><td>97.0.0.2:443</td><td>tcp</td><td>TIME_WAIT</td></tr> <tr><td>97.0.0.5:3535</td><td>97.0.0.2:443</td><td>tcp</td><td>TIME_WAIT</td></tr> <tr><td>97.0.0.5:3509</td><td>97.0.0.2:443</td><td>tcp</td><td>TIME_WAIT</td></tr> <tr><td>97.0.0.5:3467</td><td>97.0.0.2:443</td><td>tcp</td><td>TIME_WAIT</td></tr> <tr><td>97.0.0.5:3415</td><td>97.0.0.2:443</td><td>tcp</td><td>TIME_WAIT</td></tr> <tr><td>97.0.0.5:3450</td><td>97.0.0.2:443</td><td>tcp</td><td>TIME_WAIT</td></tr> <tr><td>97.0.0.5:3499</td><td>97.0.0.2:443</td><td>tcp</td><td>TIME_WAIT</td></tr> </tbody> </table>				Active Sessions				Local	Internet	Protocol	State	97.0.0.5:3465	97.0.0.2:443	tcp	TIME_WAIT	97.0.0.5:3525	97.0.0.2:443	tcp	TIME_WAIT	97.0.0.5:3491	97.0.0.2:443	tcp	TIME_WAIT	97.0.0.5:3459	97.0.0.2:443	tcp	TIME_WAIT	97.0.0.5:3487	97.0.0.2:443	tcp	TIME_WAIT	97.0.0.5:3408	97.0.0.2:443	tcp	TIME_WAIT	97.0.0.5:3493	97.0.0.2:443	tcp	TIME_WAIT	97.0.0.5:3431	97.0.0.2:443	tcp	TIME_WAIT	97.0.0.5:3479	97.0.0.2:443	tcp	TIME_WAIT	97.0.0.5:3515	97.0.0.2:443	tcp	TIME_WAIT	97.0.0.5:3501	97.0.0.2:443	tcp	TIME_WAIT	97.0.0.5:3527	97.0.0.2:443	tcp	CLOSE	192.168.75.100:500	97.0.0.32:500	udp	none	97.0.0.5:3427	97.0.0.2:443	tcp	TIME_WAIT	97.0.0.5:3519	97.0.0.2:443	tcp	CLOSE	97.0.0.5:3507	97.0.0.2:443	tcp	TIME_WAIT	97.0.0.5:3543	97.0.0.2:443	tcp	CLOSE	97.0.0.5:3437	97.0.0.2:443	tcp	TIME_WAIT	97.0.0.5:3409	97.0.0.2:443	tcp	TIME_WAIT	97.0.0.5:3497	97.0.0.2:443	tcp	TIME_WAIT	97.0.0.5:3541	97.0.0.2:443	tcp	TIME_WAIT	97.0.0.5:3489	97.0.0.2:443	tcp	TIME_WAIT	97.0.0.5:3482	97.0.0.2:443	tcp	TIME_WAIT	97.0.0.5:3535	97.0.0.2:443	tcp	TIME_WAIT	97.0.0.5:3509	97.0.0.2:443	tcp	TIME_WAIT	97.0.0.5:3467	97.0.0.2:443	tcp	TIME_WAIT	97.0.0.5:3415	97.0.0.2:443	tcp	TIME_WAIT	97.0.0.5:3450	97.0.0.2:443	tcp	TIME_WAIT	97.0.0.5:3499	97.0.0.2:443	tcp	TIME_WAIT
Active Sessions																																																																																																																																
Local	Internet	Protocol	State																																																																																																																													
97.0.0.5:3465	97.0.0.2:443	tcp	TIME_WAIT																																																																																																																													
97.0.0.5:3525	97.0.0.2:443	tcp	TIME_WAIT																																																																																																																													
97.0.0.5:3491	97.0.0.2:443	tcp	TIME_WAIT																																																																																																																													
97.0.0.5:3459	97.0.0.2:443	tcp	TIME_WAIT																																																																																																																													
97.0.0.5:3487	97.0.0.2:443	tcp	TIME_WAIT																																																																																																																													
97.0.0.5:3408	97.0.0.2:443	tcp	TIME_WAIT																																																																																																																													
97.0.0.5:3493	97.0.0.2:443	tcp	TIME_WAIT																																																																																																																													
97.0.0.5:3431	97.0.0.2:443	tcp	TIME_WAIT																																																																																																																													
97.0.0.5:3479	97.0.0.2:443	tcp	TIME_WAIT																																																																																																																													
97.0.0.5:3515	97.0.0.2:443	tcp	TIME_WAIT																																																																																																																													
97.0.0.5:3501	97.0.0.2:443	tcp	TIME_WAIT																																																																																																																													
97.0.0.5:3527	97.0.0.2:443	tcp	CLOSE																																																																																																																													
192.168.75.100:500	97.0.0.32:500	udp	none																																																																																																																													
97.0.0.5:3427	97.0.0.2:443	tcp	TIME_WAIT																																																																																																																													
97.0.0.5:3519	97.0.0.2:443	tcp	CLOSE																																																																																																																													
97.0.0.5:3507	97.0.0.2:443	tcp	TIME_WAIT																																																																																																																													
97.0.0.5:3543	97.0.0.2:443	tcp	CLOSE																																																																																																																													
97.0.0.5:3437	97.0.0.2:443	tcp	TIME_WAIT																																																																																																																													
97.0.0.5:3409	97.0.0.2:443	tcp	TIME_WAIT																																																																																																																													
97.0.0.5:3497	97.0.0.2:443	tcp	TIME_WAIT																																																																																																																													
97.0.0.5:3541	97.0.0.2:443	tcp	TIME_WAIT																																																																																																																													
97.0.0.5:3489	97.0.0.2:443	tcp	TIME_WAIT																																																																																																																													
97.0.0.5:3482	97.0.0.2:443	tcp	TIME_WAIT																																																																																																																													
97.0.0.5:3535	97.0.0.2:443	tcp	TIME_WAIT																																																																																																																													
97.0.0.5:3509	97.0.0.2:443	tcp	TIME_WAIT																																																																																																																													
97.0.0.5:3467	97.0.0.2:443	tcp	TIME_WAIT																																																																																																																													
97.0.0.5:3415	97.0.0.2:443	tcp	TIME_WAIT																																																																																																																													
97.0.0.5:3450	97.0.0.2:443	tcp	TIME_WAIT																																																																																																																													
97.0.0.5:3499	97.0.0.2:443	tcp	TIME_WAIT																																																																																																																													
Wireless Clients	<input type="button" value="Refresh"/>																																																																																																																															
LAN Clients																																																																																																																																
Active VPNs																																																																																																																																

## 10.3.2 Wireless Clients

### *Status > Wireless Clients*

The clients connected to a particular AP can be viewed on this page. Connected clients are sorted by the MAC address and indicate the security parameters used by the wireless link, as well as the time connected to the corresponding AP.

The statistics table has auto-refresh control which allows display of the most current port level data at each page refresh. The default auto-refresh for this page is 10 seconds.

**Figure 134: List of connected 802.11 clients per AP**

DSR-1000N	SETUP	ADVANCED	TOOLS	STATUS
-----------	-------	----------	-------	--------

The page will auto-refresh in 4 seconds

**WIRELESS CLIENTS** LOGOUT

This list identifies the wireless clients (or stations) currently connected to the Access Points configured and enabled on this device.

**Connected Clients**

AP Name	MAC Address	Radio	Security	Encryption	Authentication	Time Connected
---------	-------------	-------	----------	------------	----------------	----------------

Poll Interval:  (Seconds)

## 10.3.3 LAN Clients

### *Status > LAN Clients*

The LAN clients to the router are identified by an ARP scan through the LAN switch. The NetBios name (if available), IP address and MAC address of discovered LAN hosts are displayed.

**Figure 135: List of LAN hosts**

DSR-1000N	SETUP	ADVANCED	TOOLS	STATUS						
Device Info										
Logs	<b>LAN CLIENTS</b> <span style="float: right;">LOGOUT</span>									
Traffic Monitor	This page displays a list of LAN clients connected to the router.									
Active Sessions	<b>List of LAN Clients</b>									
Wireless Clients	<table border="1"> <thead> <tr> <th>Name</th> <th>IP Address</th> <th>MAC Address</th> </tr> </thead> <tbody> <tr> <td>EITHSTINTEL645</td> <td>97.0.0.5</td> <td>00:0F:1F:8E:B6:36</td> </tr> </tbody> </table>				Name	IP Address	MAC Address	EITHSTINTEL645	97.0.0.5	00:0F:1F:8E:B6:36
Name	IP Address	MAC Address								
EITHSTINTEL645	97.0.0.5	00:0F:1F:8E:B6:36								
LAN Clients										
Active VPNs										

### 10.3.4 Active VPN Tunnels

*Status > Active VPNs*

You can view and change the status (connect or drop) of the router’s IPsec security associations. Here, the active IPsec SAs (security associations) are listed along with the traffic details and tunnel state. The traffic is a cumulative measure of transmitted/received packets since the tunnel was established.

If a VPN policy state is “IPsec SA Not Established”, it can be enabled by clicking the Connect button of the corresponding policy. The Active IPsec SAs table displays a list of active IPsec SAs. Table fields are as follows.

Field	Description
Policy Name	IKE or VPN policy associated with this SA.
Endpoint	IP address of the remote VPN gateway or client.
Tx (KB)	Kilobytes of data transmitted over this SA.
Tx (Packets)	Number of IP packets transmitted over this SA.
State	Status of the SA for IKE policies: Not Connected or IPsec SA Established.

**Figure 136: List of current Active VPN Sessions**

All active SSL VPN connections, both for VPN tunnel and VPN Port forwarding, are displayed on this page as well. Table fields are as follows.

Field	Description
User Name	The SSL VPN user that has an active tunnel or port forwarding session to this router.
IP Address	IP address of the remote VPN client.
Local PPP Interface	The interface (WAN1 or WAN2) through which the session is active.
Peer PPP Interface IP	The assigned IP address of the virtual network adapter.
Connect Status	Status of the SSL connection between this router and the remote VPN client: Not Connected or Connected.

# Chapter 11. Trouble Shooting

## 11.1 Internet connection

**Symptom:** You cannot access the router's web-configuration interface from a PC on your LAN.

**Recommended action:**

1. Check the Ethernet connection between the PC and the router.
2. Ensure that your PC's IP address is on the same subnet as the router. If you are using the recommended addressing scheme, your PC's address should be in the range 192.168.10.2 to 192.168.10.254.
3. Check your PC's IP address. If the PC cannot reach a DHCP server, some versions of Windows and Mac OS generate and assign an IP address. These auto-generated addresses are in the range 169.254.x.x. If your IP address is in this range, check the connection from the PC to the firewall and reboot your PC.
4. If your router's IP address has changed and you don't know what it is, reset the router configuration to factory defaults (this sets the firewall's IP address to 192.168.10.1).
5. If you do not want to reset to factory default settings and lose your configuration, reboot the router and use a packet sniffer (such as Ethereal™) to capture packets sent during the reboot. Look at the Address Resolution Protocol (ARP) packets to locate the router's LAN interface address.
6. Launch your browser and ensure that Java, JavaScript, or ActiveX is enabled. If you are using Internet Explorer, click Refresh to ensure that the Java applet is loaded. Close the browser and launch it again.
7. Ensure that you are using the correct login information. The factory default login name is admin and the password is password. Ensure that CAPS LOCK is off when entering this information.

**Symptom:** Router does not save configuration changes.

**Recommended action:**

1. When entering configuration settings, click Apply before moving to another menu or tab; otherwise your changes are lost.
2. Click Refresh or Reload in the browser. Your changes may have been made, but the browser may be caching the old configuration.



**Symptom:** Router cannot access the Internet.

**Possible cause:** If you use dynamic IP addresses, your router may not have requested an IP address from the ISP.

**Recommended action:**

1. Launch your browser and go to an external site such as [www.google.com](http://www.google.com).
2. Access the firewall's configuration main menu at <http://192.168.10.1>.
3. Select **Monitoring > Router Status**.
4. Ensure that an IP address is shown for the WAN port. If 0.0.0.0 is shown, your firewall has not obtained an IP address from your ISP. See the next symptom.

**Symptom:** Router cannot obtain an IP address from the ISP.

**Recommended action:**

1. Turn off power to the cable or DSL modem.
2. Turn off the router.
3. Wait 5 minutes, and then reapply power to the cable or DSL modem.
4. When the modem LEDs indicate that it has resynchronized with the ISP, reapply power to the router. If the router still cannot obtain an ISP address, see the next symptom.

**Symptom:** Router still cannot obtain an IP address from the ISP.

**Recommended action:**

1. Ask your ISP if it requires a login program — PPP over Ethernet (PPPoE) or some other type of login.
2. If yes, verify that your configured login name and password are correct.
3. Ask your ISP if it checks for your PC's hostname.
4. If yes, select **Network Configuration > WAN Settings > Ethernet ISP Settings** and set the account name to the PC hostname of your ISP account.
5. Ask your ISP if it allows only one Ethernet MAC address to connect to the Internet, and therefore checks for your PC's MAC address.
6. If yes, inform your ISP that you have bought a new network device, and ask them to use the firewall's MAC address.
7. Alternatively, select **Network Configuration > WAN Settings > Ethernet ISP Settings** and configure your router to spoof your PC's MAC address.

**Symptom:** Router can obtain an IP address, but PC is unable to load Internet pages.

**Recommended action:**

1. Ask your ISP for the addresses of its designated Domain Name System (DNS) servers. Configure your PC to recognize those addresses. For details, see your operating system documentation.
2. On your PC, configure the router to be its TCP/IP gateway.

## 11.2 Date and time

**Symptom:** Date shown is January 1, 1970.

**Possible cause:** The router has not yet successfully reached a network time server (NTS).

**Recommended action:**

1. If you have just configured the router, wait at least 5 minutes, select *Administration > Time Zone*, and recheck the date and time.
2. Verify your Internet access settings.

**Symptom:** Time is off by one hour.

**Possible cause:** The router does not automatically adjust for Daylight Savings Time.

**Recommended action:**

1. Select *Administration > Time Zone* and view the current date and time settings.
2. Click to check or uncheck “Automatically adjust for Daylight Savings Time”, then click Apply.

## 11.3 Pinging to Test LAN Connectivity

Most TCP/IP terminal devices and firewalls contain a ping utility that sends an ICMP echo-request packet to the designated device. The DSR responds with an echo reply. Troubleshooting a TCP/IP network is made very easy by using the ping utility in your PC or workstation.

### 11.3.1 Testing the LAN path from your PC to your router

1. From the PC's Windows toolbar, select Start > Run.
2. Type ping <IP\_address> where <IP\_address> is the router's IP address. Example: ping 192.168.10.1.
3. Click OK.

4. Observe the display:
  - If the path is working, you see this message sequence:  
Pinging <IP address> with 32 bytes of data  
Reply from <IP address>: bytes=32 time=NN ms TTL=xxx
  - If the path is not working, you see this message sequence:  
Pinging <IP address> with 32 bytes of data  
Request timed out
5. If the path is not working, Test the physical connections between PC and router
  - If the LAN port LED is off, go to the “LED displays” section on page B-1 and follow instructions for “LAN or Internet port LEDs are not lit.”
  - Verify that the corresponding link LEDs are lit for your network interface card and for any hub ports that are connected to your workstation and firewall.
6. If the path is still not up, test the network configuration:
  - Verify that the Ethernet card driver software and TCP/IP software are installed and configured on the PC.
  - Verify that the IP address for the router and PC are correct and on the same subnet.

### 11.3.2 Testing the LAN path from your PC to a remote device

1. From the PC's Windows toolbar, select Start > Run.
2. Type ping -n 10 <IP\_address> where -n 10 specifies a maximum of 10 tries and <IP address> is the IP address of a remote device such as your ISP's DNS server. Example:  
ping -n 10 10.1.1.1.
3. Click OK and then observe the display (see the previous procedure).
4. If the path is not working, do the following:
  - Check that the PC has the IP address of your firewall listed as the default gateway. (If the IP configuration of your PC is assigned by DHCP, this information is not visible in your PC's Network Control Panel.)

- Verify that the network (subnet) address of your PC is different from the network address of the remote device.
- Verify that the cable or DSL modem is connected and functioning.
- Ask your ISP if it assigned a hostname to your PC.

If yes, select *Network Configuration > WAN Settings > Ethernet ISP Settings* and enter that hostname as the ISP account name.

- Ask your ISP if it rejects the Ethernet MAC addresses of all but one of your PCs.

Many broadband ISPs restrict access by allowing traffic from the MAC address of only your broadband modem; but some ISPs additionally restrict access to the MAC address of just a single PC connected to that modem. If this is the case, configure your firewall to clone or spoof the MAC address from the authorized PC.

## 11.4 Restoring factory-default configuration settings

To restore factory-default configuration settings, do either of the following:

1. Do you know the account password and IP address?
  - If yes, select *Administration > Settings Backup & Upgrade* and click default.
  - If no, do the following:

On the rear panel of the router, press and hold the Reset button about 10 seconds, until the test LED lights and then blinks.

Release the button and wait for the router to reboot.

2. If the router does not restart automatically; manually restart it to make the default settings effective.
3. After a restore to factory defaults —whether initiated from the configuration interface or the Reset button — the following settings apply:
  - LAN IP address: 192.168.10.1
  - Username: admin
  - Password: admin
  - DHCP server on LAN: enabled
  - WAN port configuration: Get configuration via DHCP

# Chapter 12. Credits

Microsoft, Windows are registered trademarks of Microsoft Corp.

Linux is a registered trademark of Linus Torvalds.

UNIX is a registered trademark of The Open Group.



## Appendix A. Glossary

<b>ARP</b>	Address Resolution Protocol. Broadcast protocol for mapping IP addresses to MAC addresses.
<b>CHAP</b>	Challenge-Handshake Authentication Protocol. Protocol for authenticating users to an ISP.
<b>DDNS</b>	Dynamic DNS. System for updating domain names in real time. Allows a domain name to be assigned to a device with a dynamic IP address.
<b>DHCP</b>	Dynamic Host Configuration Protocol. Protocol for allocating IP addresses dynamically so that addresses can be reused when hosts no longer need them.
<b>DNS</b>	Domain Name System. Mechanism for translating H.323 IDs, URLs, or e-mail IDs into IP addresses. Also used to assist in locating remote gatekeepers and to map IP addresses to hostnames of administrative domains.
<b>FQDN</b>	Fully qualified domain name. Complete domain name, including the host portion. Example: serverA.companyA.com.
<b>FTP</b>	File Transfer Protocol. Protocol for transferring files between network nodes.
<b>HTTP</b>	Hypertext Transfer Protocol. Protocol used by web browsers and web servers to transfer files.
<b>IKE</b>	Internet Key Exchange. Mode for securely exchanging encryption keys in ISAKMP as part of building a VPN tunnel.
<b>IPsec</b>	IP security. Suite of protocols for securing VPN tunnels by authenticating or encrypting IP packets in a data stream. IPsec operates in either transport mode (encrypts payload but not packet headers) or tunnel mode (encrypts both payload and packet headers).
<b>ISAKMP</b>	Internet Key Exchange Security Protocol. Protocol for establishing security associations and cryptographic keys on the Internet.
<b>ISP</b>	Internet service provider.
<b>MAC Address</b>	Media-access-control address. Unique physical-address identifier attached to a network adapter.
<b>MTU</b>	Maximum transmission unit. Size, in bytes, of the largest packet that can be passed on. The MTU for Ethernet is a 1500-byte packet.
<b>NAT</b>	Network Address Translation. Process of rewriting IP addresses as a packet passes through a router or firewall. NAT enables multiple hosts on a LAN to access the Internet using the single public IP address of the LAN's gateway router.
<b>NetBIOS</b>	Microsoft Windows protocol for file sharing, printer sharing, messaging, authentication, and name resolution.
<b>NTP</b>	Network Time Protocol. Protocol for synchronizing a router to a single clock on the network, known as the clock master.
<b>PAP</b>	Password Authentication Protocol. Protocol for authenticating users to a remote access server or ISP.

<b>PPPoE</b>	Point-to-Point Protocol over Ethernet. Protocol for connecting a network of hosts to an ISP without the ISP having to manage the allocation of IP addresses.
<b>PPTP</b>	Point-to-Point Tunneling Protocol. Protocol for creation of VPNs for the secure transfer of data from remote clients to private servers over the Internet.
<b>RADIUS</b>	Remote Authentication Dial-In User Service. Protocol for remote user authentication and accounting. Provides centralized management of usernames and passwords.
<b>RSA</b>	Rivest-Shamir-Adleman. Public key encryption algorithm.
<b>TCP</b>	Transmission Control Protocol. Protocol for transmitting data over the Internet with guaranteed reliability and in-order delivery.
<b>UDP</b>	User Datagram Protocol. Protocol for transmitting data over the Internet quickly but with no guarantee of reliability or in-order delivery.
<b>VPN</b>	Virtual private network. Network that enables IP traffic to travel securely over a public TCP/IP network by encrypting all traffic from one network to another. Uses tunneling to encrypt all information at the IP level.
<b>WINS</b>	Windows Internet Name Service. Service for name resolution. Allows clients on different IP subnets to dynamically resolve addresses, register themselves, and browse the network without sending broadcasts.
<b>XAUTH</b>	IKE Extended Authentication. Method, based on the IKE protocol, for authenticating not just devices (which IKE authenticates) but also users. User authentication is performed after device authentication and before IPsec negotiation.





## Appendix B. Factory Default Settings

Feature	Description	Default Setting
Device login	User login URL	http://192.168.10.1
	User name (case sensitive)	admin
	Login password (case sensitive)	admin
Internet Connection	WAN MAC address	Use default address
	WAN MTU size	1500
	Port speed	Autosense
Local area network (LAN)	IP address	192.168.10.1
	IPv4 subnet mask	255.255.255.0
	RIP direction	None
	RIP version	Disabled
	RIP authentication	Disabled
	DHCP server	Enabled
	DHCP starting IP address	192.168.10.2
	DHCP ending IP address	192.168.10.100
	Time zone	GMT
	Time zone adjusted for Daylight Saving Time	Disabled
	SNMP	Disabled
	Remote management	Disabled
Firewall	Inbound communications from the Internet	Disabled (except traffic on port 80, the HTTP port)
	Outbound communications to the Internet	Enabled (all)
	Source MAC filtering	Disabled
	Stealth mode	Enabled

---

## Appendix C. Standard Services Available for Port Forwarding & Firewall Configuration

ANY	ICMP-TYPE-8	RLOGIN
AIM	ICMP-TYPE-9	RTELNET
BGP	ICMP-TYPE-10	RTSP:TCP
BOOTP_CLIENT	ICMP-TYPE-11	RTSP:UDP
BOOTP_SERVER	ICMP-TYPE-13	SFTP
CU-SEEME:UDP	ICQ	SMTP
CU-SEEME:TCP	IMAP2	SNMP:TCP
DNS:UDP	IMAP3	SNMP:UDP
DNS:TCP	IRC	SNMP-TRAPS:TCP
FINGER	NEWS	SNMP-TRAPS:UDP
FTP	NFS	SQL-NET
HTTP	NNTP	SSH:TCP
HTTPS	PING	SSH:UDP
ICMP-TYPE-3	POP3	STRMWORKS
ICMP-TYPE-4	PPTP	TACACS
ICMP-TYPE-5	RCMD	TELNET
ICMP-TYPE-6	REAL-AUDIO	TFTP
ICMP-TYPE-7	REXEC	VDOLIVE

# Appendix D. Log Output Reference

## Facility: System(Networking)

Log Message	Severity	Log Message	Severity
DBUpdate event: Table: %s opCode:%d rowId:%d	DEBUG	BridgeConfig: too few arguments to command %s	ERROR
networkIntable.txt not found	DEBUG	BridgeConfig: too few arguments to command %s	ERROR
sqlite3QueryResGet failed	DEBUG	sqlite3QueryResGet failed.Query:%s	ERROR
Interface is already deleted in bridge	DEBUG	ddnsDisable failed	ERROR
removing %s from bridge %s... %s	DEBUG	sqlite3QueryResGet failed.Query:%s	ERROR
adding %s to bridge %s... %s	DEBUG	sqlite3QueryResGet failed.Query:%s	ERROR
stopping bridge...	DEBUG	ddnsDisable failed	ERROR
stopping bridge...	DEBUG	failed to call ddns enable	ERROR
stopping bridge...	DEBUG	ddnsDisable failed	ERROR
%s:DBUpdate event: Table: %s opCode:%d rowId:%d	DEBUG	sqlite3QueryResGet failed.Query:%s	ERROR
Wan is not up	DEBUG	Error in executing DB update handler	ERROR
%s:DBUpdate event: Table: %s opCode:%d rowId:%d	DEBUG	sqlite3QueryResGet failed.Query:%s	ERROR
doDNS:failed	DEBUG	Illegal invocation of ddns View (%s)	ERROR
doDNS:failed	DEBUG	sqlite3QueryResGet failed.Query:%s	ERROR
doDNS:Result= FAILED	DEBUG	sqlite3QueryResGet failed.Query:%s	ERROR
doDNS:Result SUCCESS	DEBUG	ddns: SQL error: %s	ERROR
Write Old Entry: %s %s %s: to %s	DEBUG	Illegal operation interface got deleted	ERROR
Write New Entry: %s %s #%s : to %s	DEBUG	sqlite3QueryResGet failed.Query:%s	ERROR
Write Old Entry: %s %s %s: to %s	DEBUG	sqlite3QueryResGet failed.Query:%s	ERROR
Write New Entry: %s %s #%s : to %s	DEBUG	sqlite3QueryResGet failed.Query:%s	ERROR
ifStaticMgmtDBUpdateHandler: returning with "	DEBUG	ddnsDisable failed	ERROR
nimfLinkStatusGet: buffer: \nimfLinkStatusGetErr: returning with status: %d	DEBUG	ddns: SQL error: %s	ERROR
nimfAdvOptSetWrap: current Mac Option: %d	DEBUG	Failed to call ddns enable	ERROR
nimfAdvOptSetWrap: current Port Speed Option: %d	DEBUG	ddns: SQL error: %s	ERROR
nimfAdvOptSetWrap: current Mtu Option: %d	DEBUG	sqlite3QueryResGet failed.Query:%s	ERROR
nimfAdvOptSetWrap: looks like we are reconnecting. "	DEBUG	Failed to call ddns enable	ERROR
nimfAdvOptSetWrap: Mtu Size: %d	DEBUG	ddns: SQL error: %s	ERROR
nimfAdvOptSetWrap: NIMF table is %s	DEBUG	ddnsDisable failed	ERROR
nimfAdvOptSetWrap:WAN_MODE TRIGGER	DEBUG	ddns: SQL error: %s	ERROR
nimfAdvOptSetWrap: MTU: %d	DEBUG	sqlite3QueryResGet failed.Query:%s	ERROR
nimfAdvOptSetWrap: MacAddress: %s	DEBUG	Failed to call ddns enable	ERROR
nimfAdvOptSetWrap: old Mtu Flag: %d	DEBUG	ddns: SQL error: %s	ERROR
nimfAdvOptSetWrap: old Mtu Flag: %d	DEBUG	ddnsDisable failed	ERROR

nimfAdvOptSetWrap: user has changed MTU option	DEBUG	ddns: SQL error: %s	ERROR
nimfAdvOptSetWrap: MTU: %d	DEBUG	sqlite3QueryResGet failed.Query:%s	ERROR
nimfAdvOptSetWrap: old MTU size: %d	DEBUG	sqlite3QueryResGet failed.Query:%s	ERROR
nimfAdvOptSetWrap: old Port Speed Option: %d	DEBUG	ddnsDisable failed	ERROR
nimfAdvOptSetWrap: old Mac Address Option: %d	DEBUG	ddns: SQL error: %s	ERROR
nimfAdvOptSetWrap: MacAddress: %s	DEBUG	sqlite3QueryResGet failed.Query:%s	ERROR
Setting LED [%d]:[%d] For %s	DEBUG	sqlite3QueryResGet failed.Query:%s	ERROR
l2tpEnable: command string: %s	DEBUG	ddnsDisable failed	ERROR
nimfAdvOptSetWrap: handling reboot scenario	DEBUG	failed to call ddns enable	ERROR
nimfAdvOptSetWrap: INDICATOR = %d	DEBUG	ddns: SQL error: %s	ERROR
nimfAdvOptSetWrap: UpdateFlag: %d	DEBUG	ddnsDisable failed	ERROR
nimfAdvOptSetWrap: returning with status: %s	DEBUG	sqlite3QueryResGet failed.Query:%s	ERROR
nimfGetUpdateMacFlag: MacTable Flag is: %d	DEBUG	Error in executing DB update handler	ERROR
nimfMacGet: Mac Option changed	DEBUG	Failed to open the resolv.conf file. Exiting./n	ERROR
nimfMacGet: Update Flag: %d	DEBUG	Could not write to the resolv.conf file. Exiting.	ERROR
nimfMacGet: MacAddress: %s	DEBUG	Error opening the lanUptime File	ERROR
nimfMacGet: MacAddress: %s	DEBUG	Error Opening the lanUptime File.	ERROR
nimfMacGet: MacAddress: %s	DEBUG	failed to open %s	ERROR
nimfMacGet: MacAddress: %s	DEBUG	failed to open %s	ERROR
nimfMacGet: MacAddress: %s	DEBUG	failed to query networkInterface table	ERROR
nimfMacGet:Mac option Not changed \	DEBUG	failed to query networkInterface table	ERROR
nimfMacGet: MacAddress: %s	DEBUG	sqlite3QueryResGet failed.Query:%s	ERROR
nimfMacGet: MacAddress: %s	DEBUG	failed to enable IPv6 forwarding	ERROR
nimfMacGet: MacAddress: %s	DEBUG	failed to set capabilities on the "	ERROR
nimfMacGet: returning with status: %s	DEBUG	failed to enable IPv6 forwarding	ERROR
Now in enableing LanBridge function	DEBUG	failed to set capabilities on the "	ERROR
sucessfullyexecuted the command %s	DEBUG	failed to disable IPv6 forwarding	ERROR
Now in disableing LanBridge function	DEBUG	failed to set capabilities on the "	ERROR
sucessfullyexecuted the command %s	DEBUG	failed to open %s	ERROR
configPortTblHandler:Now we are in Sqlite Update "	DEBUG	Could not create ISATAP Tunnel	ERROR
The Old Configuration of ConfiPort was: %s	DEBUG	Could not destroy ISATAP Tunnel	ERROR
The New Configuration of ConfiPort was: %s	DEBUG	Could not configure ISATAP Tunnel	ERROR
The user has deselected the configurable port	DEBUG	Could not de-configure ISATAP Tunnel	ERROR
failed query %s	DEBUG	nimfStatusUpdate: updating NimfStatus failed	ERROR
failed query %s	DEBUG	nimfStatusUpdate: updating NimfStatus failed	ERROR
failed query %s	DEBUG	nimfLinkStatusGet: determinig link's status failed	ERROR
%s:DBUpdate event: Table: %s opCode: %d rowId: %d	DEBUG	nimfLinkStatusGet: opening status file failed	ERROR

%s:DBUUpdate event: Table: %s opCode:%d rowId:%d	DEBUG	Failed to commit	ERROR
%s:%d SIP ENABLE: %s	DEBUG	ifStatusDBUUpdate: Failed to begin "	ERROR
sipTblHandler:failed to update ifStatic	DEBUG	%s: SQL error: %s	ERROR
sipTblHandler:failed to update Configport	DEBUG	%s: Failed to commit "	ERROR
%s:%d SIP DISABLE: %s	DEBUG	nimfNetIfaceTblHandler: unable to get LedPinId	ERROR
%s:%d SIP SET CONF: %s	DEBUG	nimfNetIfaceTblHandler: unable to get LedPinId	ERROR
Failed to open %s: %s	DEBUG	nimfNetIfaceTblHandler: unable to get LedPinId	ERROR
Failed to start sipalg	DEBUG	%s: unable to kill dhclient	ERROR
Failed to stop sipalg	DEBUG	nimfAdvOptSetWrap: unable to get current Mac Option	ERROR
Failed to get config info	DEBUG	nimfAdvOptSetWrap: unable to get current Port "	ERROR
Network Mask: 0x%x	DEBUG	nimfAdvOptSetWrap: unable to get current MTU Option	ERROR
RTP DSCP Value: 0x%x	DEBUG	nimfAdvOptSetWrap: error getting Mac Address from "	ERROR
Need more arguments	DEBUG	nimfAdvOptSetWrap: unable to get the MTU	ERROR
Invalid lanaddr	DEBUG	nimfAdvOptSetWrap: error setting interface advanced "	ERROR
Invalid lanmask	DEBUG	nimfAdvOptSetWrap: error getting MTU size	ERROR
Invalid option	DEBUG	nimfAdvOptSetWrap: unable to get Mac Address	ERROR
Failed to set config info	DEBUG	nimfAdvOptSetWrap: error setting interface advanced "	ERROR
Unknown option	DEBUG	nimfAdvOptSetWrap: failed to get old connectiontype	ERROR
sshdTblHandler	DEBUG	nimfAdvOptSetWrap: old connection type is: %s	ERROR
pPort: %s	DEBUG	nimfAdvOptSetWrap: failed to get old MTU Option	ERROR
pProtocol: %s	DEBUG	nimfAdvOptSetWrap: error getting MTU size	ERROR
pListerAddr: %s	DEBUG	nimfOldFieldValueGet: failed to get old "	ERROR
pKeyBits: %s	DEBUG	nimfOldFieldValueGet: user has changed MTU size	ERROR
pRootEnable: %s	DEBUG	nimfAdvOptSetWrap: failed to get old Port Speed "	ERROR
pRsaEnable: %s	DEBUG	nimfAdvOptSetWrap: user has changed Port Speed	ERROR
pDsaEnable: %s	DEBUG	nimfAdvOptSetWrap: failed to get old Mac Address "	ERROR
pPassEnable: %s	DEBUG	nimfAdvOptSetWrap: user has changed Mac Address "	ERROR
pEmptyPassEnable: %s	DEBUG	nimfAdvOptSetWrap: unable to get Mac Address	ERROR
pSftpEnable: %s	DEBUG	nimfAdvOptSetWrap:Failed to RESET the flag	ERROR
pScpEnable: %s	DEBUG	nimfAdvOptSetWrap: setting advanced options failed	ERROR
pSshdEnable: %s	DEBUG	nimfAdvOptSetWrap: interface advanced options applied	ERROR

pPrivSep: %s	DEBUG	nimfGetUpdateMacFlag: unable to get Flag from MacTable	ERROR
%s:DBUpdate event: Table: %s opCode:%d rowId:%d	DEBUG	nimfMacGet: Updating MAC address failed	ERROR
Re-Starting sshd daemon....	DEBUG	sqlite3QueryResGet failed.Query:%s	ERROR
sshd re-started successfully.	DEBUG	error executing the command %s	ERROR
sshd stopped .	DEBUG	error executing the command %s	ERROR
failed query %s	DEBUG	error executing the command %s	ERROR
vlan disabled, not applying vlan configuration..	DEBUG	disableLan function is failed to disable ConfigPort"	ERROR
failed query %s	DEBUG	sqlite3QueryResGet failed.Query:%s	ERROR
failed query %s	DEBUG	sqlite3QueryResGet failed.Query:%s	ERROR
no ports present in this vlanId %d	DEBUG	Unable to Disable configurable port from	ERROR
failed query %s	DEBUG	configPortTblHandler has failed	ERROR
vlan disabled, not applying vlan configuration..	DEBUG	sqlite3QueryResGet failed.Query:%s	ERROR
disabling vlan	DEBUG	Error in executing DB update handler	ERROR
enabling vlan	DEBUG	sqlite3QueryResGet failed	ERROR
vlan disabled, not applying vlan configuration..	DEBUG	Failed to execute switchConfig for port\	ERROR
no ports present in this vlanId %d	DEBUG	Failed to execute switchConfig for port enable	ERROR
failed query %s	DEBUG	Failed to execute ifconfig for port enable	ERROR
vlan disabled, not applying vlan configuration..	DEBUG	Failed to execute ethtool for\	ERROR
removing %s from bridge%s... %s	DEBUG	Failed to execute switchConfig for port disable	ERROR
adding %s to bridge%d... %s	DEBUG	Failed to execute ifconfig for port disable	ERROR
restarting bridge...	DEBUG	sqlite3QueryResGet failed	ERROR
[switchConfig] Ignoring event on port number %d	DEBUG	sqlite3_mprintf failed	ERROR
restarting bridge...	DEBUG	sqlite3QueryResGet failed	ERROR
executing %s ... %s	DEBUG	Failed to execute switchConfig for port mirroring	ERROR
removing %s from bridge%s... %s	DEBUG	Usage:%s <DB Name> <Entry Name> <logFile> <subject>	ERROR
adding %s to bridge%d... %s	DEBUG	sqlite3QueryResGet failed	ERROR
[switchConfig] Ignoring event on %s	DEBUG	Could not get all the required variables to email the Logs.	ERROR
restarting bridge...	DEBUG	runSmtplibClient failed	ERROR
[switchConfig] Ignoring event on port number %d	DEBUG	getaddrinfo returned %s	ERROR
[switchConfig] executing %s ... %s	DEBUG	file not found	ERROR
restarting bridge...	DEBUG	sqlite3QueryResGet failed.Query:%s	ERROR
UserName: %s	DEBUG	sqlite3QueryResGet failed.Query:%s	ERROR
Password: %s	DEBUG	sqlite3QueryResGet failed.Query:%s	ERROR
lspName: %s	DEBUG	No memory to allocate	ERROR
DialNumber: %s	DEBUG	Failed to Open SSHD Configuration File	ERROR
Apn: %s	DEBUG	laddress should be provided with access option 1	ERROR

GetDnsFromIsp: %s	DEBUG	Subnetaddress should be provided with accessoption 2	ERROR
IdleTimeOutFlag: %s	DEBUG	Failed to restart sshd	ERROR
IdleTimeOutValue: %d	DEBUG	unable to open the "	ERROR
AuthMetho: %d	DEBUG	sqlite3QueryResGet failed.Query:%s	ERROR
executing %s ... %s	DEBUG	Error in executing DB update handler	ERROR
removing %s from bridge%d... %s	DEBUG	Error in executing DB update handler	ERROR
adding %s to bridge%d... %s	DEBUG	unknown vlan state	ERROR
stopping bridge...	DEBUG	Failed to execute vlanConfig binary for vlanId %d	ERROR
restarting bridge...	DEBUG	sqlite3_mprintf failed	ERROR
Could not configure 6to4 Tunnel Interface	DEBUG	Access port can be present only in single vlan	ERROR
Could not de-configure 6to4 Tunnel Interface	DEBUG	Failed to execute vlanConfig binary for vlanId %d	ERROR
failed to restart 6to4 tunnel interfaces	DEBUG	unknown vlan state	ERROR
BridgeConfig: too few arguments to command %s	DEBUG	Failed to execute vlanConfig binary for port number %d	ERROR
BridgeConfig: unsupported command %d	DEBUG	Failed to clear vlan for oldPVID %d	ERROR
BridgeConfig returned error=%d	DEBUG	Failed to execute vlanConfig binary for port number %d	ERROR
sqlite3QueryResGet failed	DEBUG	Failed to clear vlan for %d	ERROR
Error in executing DB update handler	DEBUG	Failed to set vlan entry for vlan %d	ERROR
sqlite3QueryResGet failed	DEBUG	Failed to set vlan entries, while enabling \	ERROR
Failed to remove vlan Interface for vlanId \	DEBUG	sqlite3QueryResGet failed	ERROR
sqlite3QueryResGet failed	DEBUG	Failed to execute vlanConfig binary for port number %d	ERROR
Invalid oidp passed	DEBUG	Failed to execute vlanConfig binary for vlanId %d	ERROR
Invalid oidp passed	DEBUG	Failed to enable vlan	ERROR
Failed to get oid from the tree	DEBUG	Failed to disable vlan	ERROR
threegEnable: Input to wrapper %s	DEBUG	Failed to set vlanPort table entries, while \	ERROR
threegEnable: spawning command %s	DEBUG	Failed to enable vlan	ERROR
threegMgmtHandler: querystring: %s	DEBUG	unknown vlan state	ERROR
threegMgmtHandler: returning with status: %s	DEBUG	Error in executing DB update handler	ERROR
adding to dhcpreallyifgroup failed	DEBUG	unknown vlan state	ERROR
adding to ipset fwDhcpRelayfailed	DEBUG	Failed to execute vlanConfig binary for vlanId %d	ERROR
Disabling Firewall Rule for DHCP Relay Protocol	DEBUG	sqlite3_mprintf failed	ERROR
Enabling Firewall Rule for DHCP Relay Protocol	DEBUG	Access port can be present only in single vlan	ERROR
prerouting Firewall Rule add for Relay failed	DEBUG	Failed to execute vlanConfig binary for vlanId %d	ERROR
prerouting Firewall Rule add for Relay failed	DEBUG	unknown vlan state	ERROR
%s: SQL get query: %s	DEBUG	Failed to execute vlanConfig binary for port number %d	ERROR
%s: sqlite3QueryResGet failed	DEBUG	Failed to clear vlan for oldPVID %d	ERROR
%s: no result found	DEBUG	Failed to execute vlanConfig binary for port number %d	ERROR

%s: buffer overflow	DEBUG	Failed to clear vlan for %d	ERROR
%s: value of %s in %s table is: %s	DEBUG	Failed to set vlan entry for vlan %d	ERROR
%s: returning with status: %s	DEBUG	Failed to set vlan entries, while enabling \	ERROR
dnsResolverConfigure: addressFamily: %d	DEBUG	Failed to execute vlanConfig binary for port number %d	ERROR
dnsResolverConfigure: LogicalIfName: %s	DEBUG	Failed to execute vlanConfig binary for vlanId %d	ERROR
chap-secrets File found	DEBUG	Failed to enable vlan	ERROR
PID File for x12tpd found	DEBUG	Failed to disable vlan	ERROR
pid: %d	DEBUG	Failed to set vlanPort table entries, while \	ERROR
options.x12tpd file found	DEBUG	Failed to enable vlan	ERROR
options.x12tpd file not found	DEBUG	unknown vlan state	ERROR
Conf File for x12tpd found	DEBUG	threegMgmtInIt: unable to open the database file %s	ERROR
x12tpd.conf not found	DEBUG	threegConnEnable: failed to get the WanMode	ERROR
Chap Secrets file found	DEBUG	threegEnable: spawning failed	ERROR
Chap Secrets file not found	DEBUG	threegDisable: unable to kill ppp daemon	ERROR
%s:DBUpdate event: Table: %s opCode:%d rowId:%d	DEBUG	threegMgmtHandler: Query: %s	ERROR
chap-secrets File found	DEBUG	threegMgmtHandler: error in executing database update	ERROR
PID File for pptpd found	DEBUG	Error in executing DB update handler	ERROR
pid: %d	DEBUG	are we getting invoked twice ??	ERROR
PID File for pptpd interface found	DEBUG	could not open %s to append	ERROR
pid: %d	DEBUG	could not write nameserver %s to %s	ERROR
options.pptpd file found	DEBUG	could not write nameserver %s to %s	ERROR
options.pptpd file not found	DEBUG	could not open %s to truncate	ERROR
Conf File for pptpd found	DEBUG	dnsResolverConfigMgmtInIt: unable to open the "	ERROR
pptpd.conf not found	DEBUG	resolverConfigDBUpateHandler: sqlite3QueryResGet "	ERROR
Chap Secrets file found	DEBUG	could not configure DNS resolver	ERROR
Chap Secrets file not found	DEBUG	dnsResolverConfigure: could not write nameserver:%s,"	ERROR
%s:DBUpdate event: Table: %s opCode:%d rowId:%d	DEBUG	unboundMgmt: unable to open the "	ERROR
chap-secrets File found	DEBUG	ioctl call Failed-could not update active user Details	ERROR
pppoeMgmtTblHandler: MtuFlag: %d	DEBUG	sqlite3QueryResGet failed.Query:%s	ERROR
pppoeMgmtTblHandler: Mtu: %d	DEBUG	Can't kill x12tpd	ERROR
pppoeMgmtTblHandler: IdleTimeOutFlag: %d	DEBUG	x12tpd restart failed	ERROR
pppoeMgmtTblHandler: IdleTimeOutValue: %d	DEBUG	failed to get field value	ERROR
pppoeMgmtTblHandler: UserName: %s	DEBUG	failed to get field value	ERROR
pppoeMgmtTblHandler: Password: %s	DEBUG	sqlite3QueryResGet failed.Query:%s	ERROR
pppoeMgmtTblHandler: DNS specified: %s	DEBUG	sqlite3QueryResGet failed.Query:%s	ERROR
pppoeMgmtTblHandler: Service: %s	DEBUG	unboundMgmt: unable to open the "	ERROR
pppoeMgmtTblHandler: StaticIp: %s	DEBUG	writing options.x12tpd failed	ERROR



pppoeMgmtTblHandler: NetMask: %s	DEBUG	xl2tpdStop failed	ERROR
pppoeMgmtTblHandler: AuthOpt: %d	DEBUG	writing xl2tpd.conf failed	ERROR
pppoeMgmtTblHandler: Satus: %d	DEBUG	writing options.xl2tpd failed	ERROR
pppoeEnable: ppp dial string: %s	DEBUG	xl2tpdStop failed	ERROR
pppoeMgmtDBUpdateHandler: returning with status: %s	DEBUG	xl2tpdStart failed	ERROR
pptpMgmtTblHandler: MtuFlag: %d	DEBUG	sqlite3QueryResGet failed.Query:%s	ERROR
pptpMgmtTblHandler: Mtu: %d	DEBUG	writing Chap-secrets/Pap-Secrets failed	ERROR
pptpMgmtTblHandler: IdleTimeOutFlag: %d	DEBUG	xl2tpdStop failed	ERROR
pptpMgmtTblHandler: IdleTimeOutValue: %d	DEBUG	xl2tpdStart failed	ERROR
pptpMgmtTblHandler: GetDnsFromIsp: %d	DEBUG	sqlite3QueryResGet failed.Query:%s	ERROR
pptpMgmtTblHandler: UserName: %s	DEBUG	writing Chap-secrets/Pap-Secrets failed	ERROR
pptpMgmtTblHandler: Password: %s	DEBUG	xl2tpdStop failed	ERROR
pptpMgmtTblHandler: dynamic MyIp configured	DEBUG	xl2tpdStart failed	ERROR
pptpMgmtTblHandler: MyIp: %s	DEBUG	sqlite3QueryResGet failed.Query:%s	ERROR
pptpMgmtTblHandler: ServerIp: %s	DEBUG	writing Chap-secrets/Pap-Secrets failed	ERROR
pptpMgmtTblHandler: StaticIp: %s	DEBUG	Error in executing DB update handler	ERROR
pptpMgmtTblHandler: NetMask: %s	DEBUG	unboundMgmt: unable to open the "	ERROR
pptpMgmtTblHandler: MppeEncryptSupport: %s	DEBUG	Can't kill pptpd	ERROR
pptpMgmtTblHandler: SplitTunnel: %s	DEBUG	pptpd restart failed	ERROR
pptpEnable: ppp dial string: %s	DEBUG	Can't kill pptpd	ERROR
pptpEnable: spawning command %s	DEBUG	failed to get field value	ERROR
PID File for dhcpc found	DEBUG	failed to get field value	ERROR
pid: %d	DEBUG	unboundMgmt: unable to open the "	ERROR
pptpMgmtDBUpdateHandler: query string: %s	DEBUG	writing options.pptpd failed	ERROR
pptpMgmtDBUpdateHandler: returning with status: %s	DEBUG	pptpdStop failed	ERROR
dhcpcReleaseLease: dhcpc release command: %s	DEBUG	writing pptpd.conf failed	ERROR
dhcpcMgmtTblHandler: MtuFlag: %d	DEBUG	writing options.pptpd failed	ERROR
dhcpcMgmtTblHandler: Mtu: %d	DEBUG	pptpdStop failed	ERROR
DHCPv6 Server started successfully.	DEBUG	pptpdStart failed	ERROR
DHCPv6 Server stopped successfully	DEBUG	writing Chap-secrets/Pap-Secrets failed	ERROR
DHCPv6 Client started successfully.	DEBUG	Error in executing DB update handler	ERROR
DHCPv6 Client stopped successfully.	DEBUG	pppStats Update: unable to get default MTU	ERROR
DHCPv6 Client Restart successful	DEBUG	pppoeMgmtInIt: unable to open the database file %s	ERROR
l2tpMgmtTblHandler: MtuFlag: %d	DEBUG	pppoeDisable: unable to kill ppp daemon	ERROR
l2tpMgmtTblHandler: Mtu: %d	DEBUG	pppoeMultipleEnableDisable: pppoe enable failed	ERROR
l2tpMgmtTblHandler: IspName: %s	DEBUG	pppoeMultipleEnableDisable: pppoe disable failed	ERROR

I2tpMgmtTbiHandler: UserName: %s	DEBUG	pppoeMgmtTbiHandler: unable to get current Mtu Option	ERROR
I2tpMgmtTbiHandler: Password: %s	DEBUG	pppoeMgmtTbiHandler: unable to get the Mtu	ERROR
I2tpMgmtTbiHandler: AccountName: %s	DEBUG	pppoeMgmtTbiHandler: pppoe enable failed	ERROR
I2tpMgmtTbiHandler: DomainName: %s	DEBUG	pppoeMgmtDBUpdateHandler: failed query: %s	ERROR
I2tpMgmtTbiHandler: Secret: not specified	DEBUG	pppoeMgmtDBUpdateHandler: error in executing "	ERROR
I2tpMgmtTbiHandler: Secret: %s	DEBUG	pptpMgmtInIt: unable to open the database file %s	ERROR
I2tpMgmtTbiHandler: dynamic MyIp configured	DEBUG	pptpEnable: error executing command: %s	ERROR
I2tpMgmtTbiHandler: MyIp: %s	DEBUG	pptpEnable: unable to resolve address: %s	ERROR
I2tpMgmtTbiHandler: ServerIp: %s	DEBUG	pptpEnable: inet_aton failed	ERROR
I2tpMgmtTbiHandler: StaticIp: %s	DEBUG	pptpEnable: inet_aton failed	ERROR
I2tpMgmtTbiHandler: NetMask: %s	DEBUG	pptpEnable: spawning failed	ERROR
I2tpMgmtTbiHandler: SplitTunnel: %s	DEBUG	pptpDisable: unable to kill ppp daemon	ERROR
needToStartHealthMonitor: returning with status: %s	DEBUG	pptpMgmtTbiHandler: unable to get current MTU Option	ERROR
I2tpEnable: command string: %s	DEBUG	pptpMgmtTbiHandler: unable to get the Mtu	ERROR
I2tpEnable: command: %s	DEBUG	pptpMgmtTbiHandler: dbRecordValueGet failed for %s "	ERROR
I2tpEnable: command string: %s	DEBUG	pptpMgmtTbiHandler: pptp enable failed	ERROR
PID File for dhcpc found	DEBUG	pptpMgmtTbiHandler: pptp disable failed	ERROR
pid: %d	DEBUG	pptpMgmtDBUpdateHandler: sqlite3QueryResGet "	ERROR
I2tpMgmtDBUpdateHandler: querystring: %s	DEBUG	pptpMgmtDBUpdateHandler: error in executing "	ERROR
I2tpMgmtDBUpdateHandler: returning with status: %s	DEBUG	Illegal invocation of dhcpConfig (%s)	ERROR
RADVD started successfully	DEBUG	dhcpLibInIt: unable to open the database file %s	ERROR
RADVD stopped successfully	DEBUG	sqlite3QueryResGet failed.Query:%s	ERROR
empty update. nRows=%d nCols=%d	WARN	dhcpcMgmtInIt: unable to open the database file %s	ERROR
Wan is not up or in load balancing mode	WARN	dhcpcReleaseLease: unable to release lease	ERROR
threegMgmtHandler: no row found. nRows = %d nCols = %d	WARN	dhcpcEnable: unable to kill dhclient	ERROR
pppoeMgmtDBUpdateHandler: empty update.	WARN	dhcpcEnable: enabling dhcpc failed on: %s	ERROR
dhcpcEnable: dhclientalreadyrunning on: %s	WARN	dhcpcDisable: unable to kill dhclient	ERROR
dhcpcDisable: deleted dhclient.leases	WARN	dhcpcDisable: delete failed for dhclient.leases	ERROR
I2tpMgmtInIt: unable to open the database file %s	ERROR	dhcpcDisable: failed to reset the ip	ERROR
I2tpEnable: unable to resolve address: %s	ERROR	dhcpcMgmtTbiHandler: unable to get current Mtu Option	ERROR
I2tpEnable: inet_aton failed	ERROR	dhcpcMgmtTbiHandler: unable to get the Mtu	ERROR

The Enable Command is %s	ERROR	dhcpcMgmtTbIHandler: dhclient enable failed	ERROR
I2tpEnable:Executing the Command failed	ERROR	dhcpcMgmtTbIHandler: dhcpc release failed	ERROR
I2tpDisable: command string: %s	ERROR	dhcpcMgmtTbIHandler: dhcpc disable failed	ERROR
I2tpDisable: unable to stop I2tp session	ERROR	dhcpcMgmtDBUpdateHandler: failed query: %s	ERROR
I2tpMgmtTbIHandler: unable to get current MTU option	ERROR	dhcpcMgmtDBUpdateHandler: error in executing "	ERROR
I2tpMgmtTbIHandler: unable to get the Mtu	ERROR	DHCPv6 Client start failed.	ERROR
I2tpMgmtTbIHandler: dbRecordValueGet failed for %s "	ERROR	DHCPv6 Client stop failed.	ERROR
I2tpMgmtTbIHandler: I2tpEnable failed	ERROR	failed to create/open DHCPv6 client "	ERROR
I2tpMgmtTbIHandler: disabling I2tp failed	ERROR	failed to write DHCPv6 client configuration file	ERROR
I2tpMgmtDBUpdateHandler: sqlite3QueryResGet "	ERROR	failed to restart DHCPv6 Client	ERROR
I2tpMgmtDBUpdateHandler: error in executing	ERROR	failed to create/open DHCPv6 Server "	ERROR
Illegal invocation of tcpdumpConfig (%s)	ERROR	Restoring old configuration..	ERROR
Failed to start tcpdump	ERROR	DHCPv6 Server configuration update failed	ERROR
Failed to stop tcpdump	ERROR	DHCPv6 Server Restart failed	ERROR
Invalid tcpdumpEnable value	ERROR	sqlite3QueryResGet failed.Query:%s	ERROR

**Facility: System (VPN)**

Log Message	Severity	Log Message	Severity
%d command not supported by eapAuth	DEBUG	PEAP key derive: ERROR	ERROR
pCtx NULL.	DEBUG	PEAP context is NULL: ERROR	ERROR
Current cert subject name= %s	DEBUG	Constructing P2 response: ERROR	ERROR
X509_STORE_CTX_get_ex_data failed.	DEBUG	innerEapRecvis NULL: ERROR	ERROR
Cannot get cipher, no session est.	DEBUG	Decrypting TLS data: ERROR	ERROR
%s: SSL_ERROR_WANT_X509_LOOKUP	DEBUG	Wrong identity size: ERROR	ERROR
err code = (%d) in %s	DEBUG	Wrong size for extensions packet: ERROR	ERROR
BIO_write: Error	DEBUG	innerEapRecvis NULL: ERROR.	ERROR
Decrypting: BIO reset failed	DEBUG	Inner EAP processing: ERROR	ERROR
Encrypting BIO reset: ERROR	DEBUG	TLS handshake: ERROR.	ERROR
BIO_read: Error	DEBUG	Sending P1 response: ERROR	ERROR
EAP state machine changed from %s to %s.	DEBUG	Unexpected tlsGlueContinue return value.	ERROR
EAP state machine changed from %s to %s.	DEBUG	No more fragments in message. ERROR	ERROR
Received EAP Packet with code %d	DEBUG	No phase 2 data or phase 2 data buffer NULL: ERROR	ERROR
Response ID %d	DEBUG	Allocating memory for PEAP Phase 2 payload: ERROR	ERROR
Response Method %d	DEBUG	TLS encrypting response: ERROR	ERROR

Created EAP/PEAP context: OK	DEBUG	Setting message in fragment buffer: ERROR	ERROR
Deleted EAP/PEAP context: OK	DEBUG	Allocating TLS read buffer is NULL: ERROR	ERROR
Upper EAP sent us: decision = %d method state = %d	DEBUG	Setting last fragment: ERROR	ERROR
P2 decision=(%d); methodState=(%d)	DEBUG	Getting message: ERROR	ERROR
Writing message to BIO: ERROR.	DEBUG	Processing PEAP message: ERROR	ERROR
Encrypted (%d) bytes for P2	DEBUG	Setting fragment: ERROR	ERROR
P2: sending fragment.	DEBUG	Creating receive buffer: ERROR	ERROR
P2: message size = %d	DEBUG	Setting first fragment: ERROR	ERROR
P2: sending unfragmented message.	DEBUG	Sending P1 response: ERROR	ERROR
P1: Sending fragment.	DEBUG	NULL request (or response) PDU or NULL context: ERROR	ERROR
P1: Total TLS message size = (%d)	DEBUG	Expecting start packet, got something else: ERROR	ERROR
P1: sending unfragmented message.	DEBUG	Protocol version mismatch: ERROR	ERROR
peapFragFirstProcess: TLS record size to receive = (%d)	DEBUG	Processing PEAP message (from frag): ERROR	ERROR
Setting version %d	DEBUG	Processing PEAP message: ERROR	ERROR
PEAP pkt rcvd: data len=(%d) flags=(%d) version=(%d)	DEBUG	Processing PEAP message: ERROR	ERROR
Got PEAP/Start packet.	DEBUG	Indicated length not valid: ERROR	ERROR
Got first fragment	DEBUG	Did not get Acknowledged result: ERROR	ERROR
Got fragment (n)	DEBUG	Cannot understand AVP value: ERROR	ERROR
Got last fragment	DEBUG	eapExtResp is NULL: ERROR	ERROR
Got unfragmented message	DEBUG	eapWscCtxCreate: EAPAUTH_MALLOC failed.	ERROR
Got frag ack.	DEBUG	eapWscProcess: umilocctl req to WSC failed, status = %d	ERROR
Ext AVP parsed: flags=(0x%x)	DEBUG	eapWscCheck: Invalid frame	ERROR
Mandatory bit not set: WARNING	DEBUG	eapWscBuildReq: Invalid state %d	ERROR
Ext AVP parsed: type=(%d)	DEBUG	eapWscProcessWscResp: Invalid data recd pData = %p, dataLen"	ERROR
Ext AVP parsed: value=(%d)	DEBUG	Data received for invalid context, dropping it	ERROR
Got PEAPv0 success!	DEBUG	eapWscProcessWscResp: Build Request failed	ERROR
Got PEAPv0 failure!	DEBUG	eapWscProcessWscResp: Invalid state %d	ERROR
pCtx NULL.	DEBUG	eapWscProcessWscResp: Message processing failed 0x%X	ERROR
Authenticator response check: Error	DEBUG	eapWscProcessWscData: Invalid notification recd %d	ERROR
Authenticator response check: Failed	DEBUG	unable to initialize MD5	ERROR
MS-CHAP2 Response AVP size = %u	DEBUG	MDString: adpDigestInit for md5 failed	ERROR
Created EAP/MS-CHAP2 context: OK.	DEBUG	EAPAUTH_MALLOC failed.	ERROR
pCtx NULL.	DEBUG	EAPAUTH_MALLOC failed.	ERROR
Deleted EAP/MS-CHAPv2 context: OK	DEBUG	NULL context created: Error	ERROR
Not authenticated yet.	DEBUG	NULL context received: Error	ERROR
Authenticator response invalid	DEBUG	Authenticator ident invalid.	ERROR
EAP-MS-CHAPv2 password changed.	DEBUG	Success request message invalid:	ERROR

		Error	
rcvd. opCode %d.	DEBUG	Plugin context is NULL	ERROR
pCtx NULL.	DEBUG	Deriving implicit challenge: Error	ERROR
TLS message len changed in the fragment, ignoring.	DEBUG	Generating NT response: Error	ERROR
no data to send while fragment ack received.	DEBUG	NULL in/out buffer: Error	ERROR
TLS handshake successful.	DEBUG	Incorrect vendor id.	ERROR
Created EAP/TTLS context: OK	DEBUG	Allocating memory for outBuff: ERROR	ERROR
Deleted EAP/TTLS context: OK	DEBUG	AVP code not recognized	ERROR
No more fragments in message. ERROR	DEBUG	EAPAUTH_MALLOCC failed.	ERROR
Upper EAP sent us: method state = %d; decision = %d	DEBUG	Converting password to unicode: Error	ERROR
P2: sending fragment.	DEBUG	Generating password hash: Error.	ERROR
P2 send unfragmented message.	DEBUG	Generating password hash hash: Error.	ERROR
P1: sending fragment.	DEBUG	Generating master key: Error.	ERROR
P1: sending unfragmented message.	DEBUG	Generating first 16 bytes of session key: Error.n	ERROR
\tTlSMsgLen = 0x%x	DEBUG	Generating second 16 bytes of session key: Error.n	ERROR
Send req ptr = 0x%x; Send resp ptr = 0x%x	DEBUG	Converting password to unicode: Error	ERROR
P2 decision=(%d); methodState=(%d)	DEBUG	Constructing failure response: ERROR	ERROR
Default EAP: method state = %d; decision = %d	DEBUG	Error checking authenticator response.	ERROR
TTLS pkt: data len=(%d) flags=(0x%x)	DEBUG	Error generating NT response.	ERROR
Got start	DEBUG	Username string more than 256 ASCII characters: ERROR	ERROR
Got first fragment (n).	DEBUG	Invalid Value-Size.	ERROR
Got fragment (n).	DEBUG	Invalid MS-Length. Got (%d), expected (%d)	ERROR
Got last fragment	DEBUG	Error constructing response.	ERROR
Got unfragmented message.	DEBUG	Got type (%d), expecting (%d)	ERROR
Got frag ack.	DEBUG	Cannot handle message; opCode = %d	ERROR
Rcvd. AVP Code-%u: flags-0x%x: len-%u: vendorId-%u: "	DEBUG	EAPAUTH_MALLOCC failed.	ERROR
MOD EAP: method state from upper = %d; decision = %d	DEBUG	tlsGlueCtxCreate failed.	ERROR
Got AVP len = %u. Should be less than 16777215	DEBUG	client certificate must be set in the profile.	ERROR
AVP length extract: Error	DEBUG	received tls message length too big.	ERROR
pFB is NULL	DEBUG	total frags len > initial total tls length.	ERROR
Requesting message before assembly complete	DEBUG	total frags len > initial total tls length.	ERROR
pFB is NULL	DEBUG	total data rcvd(%d) doesnt match the initial "	ERROR
pFB is NULL	DEBUG	couldnt write %d data to TLS buffer.	ERROR
Buffer cannot hold message: ERROR	DEBUG	invalid flags %s passed to eapTlsBuildResp.	ERROR
pFB is NULL: Error	DEBUG	EAPAUTH_MALLOCC failed.	ERROR
pFB is NULL	DEBUG	tlsGlueCtxCreate failed.	ERROR
TLS_FB* is NULL.	DEBUG	Context NULL: ERROR	ERROR

pFB->msgBuff is NULL.	DEBUG	Setting profile to glue layer: ERROR.	ERROR
Error calculating binary.	DEBUG	_eapCtxCreate failed.	ERROR
Error calculating binary.	DEBUG	%d authentication not enabled in the system.	ERROR
adpDigestInit for SHA1 failed.	DEBUG	Initializing inner non-EAP auth plugin: ERROR	ERROR
adpDigestInit for SHA1 failed.	DEBUG	TTLS key derive: ERROR	ERROR
E = %d	DEBUG	TTLS context from EAP plugin is NULL: ERROR	ERROR
R = %d	DEBUG	Allocating memory for TTLS Phase 2 payload: ERROR	ERROR
Could not initialize des-ecb	DEBUG	TLS Encrypting response: ERROR	ERROR
adpDigestInit for MD4 failed.	DEBUG	Allocating TLS read buffer is NULL: ERROR	ERROR
adpDigestInit for SHA1 failed.	DEBUG	Inner authentication (id: %d) unhandled	ERROR
adpDigestInit for SHA1 failed.	DEBUG	innerEapRecv is NULL: ERROR.	ERROR
Error converting received auth response to bin.	DEBUG	Decrypting TLS data: ERROR	ERROR
Generating challenge hash: Error	DEBUG	Processing Phase 2 method: Error	ERROR
Generating password hash: Error	DEBUG	Writing message to BIO: ERROR.	ERROR
Generating challenge response: Error	DEBUG	TLS handshake: ERROR.	ERROR
Conn cipher name=%s ver=%s: %s	DEBUG	Unexpected tlsGlueContinue return value.	ERROR
Send req ptr = 0x%x; Send resp ptr = 0x%x	DEBUG	NULL request (or response) PDU or NULL context	ERROR
Request ptr = 0x%x;	DEBUG	Protocol version mismatch: ERROR	ERROR
Response ptr = 0x%x	DEBUG	Creating receive buffer: ERROR	ERROR
Rcvd. AVP Code - %ul	DEBUG	Setting first fragment: ERROR	ERROR
Rcvd. AVP flags - 0x%02x	DEBUG	Setting fragment: ERROR	ERROR
Rcvd. AVP len - %ul	DEBUG	Setting last fragment: ERROR	ERROR
Rcvd. AVP vendor id - %ul	DEBUG	Getting message: ERROR	ERROR
\tCode = %d	DEBUG	Processing TTLS message: ERROR	ERROR
\tIdent = %d	DEBUG	Processing TTLS message: ERROR	ERROR
\tLen = %d	DEBUG	Processing TTLS message: ERROR	ERROR
\tType = %d	DEBUG	Decapsulating AVP: ERROR	ERROR
\tOpCode = %d	DEBUG	Processing EAP receive: Error	ERROR
\tMSID = %d	DEBUG	AVP code not EAP: Error	ERROR
\tmsLen = %d	DEBUG	Encapsulating AVP: ERROR	ERROR
\tvalSize = %d	DEBUG	profile %s does not exist.	ERROR
Frag Buffer bytes left = (%d)	DEBUG	profile %s is in use.	ERROR
Stripped username=(%s)	DEBUG	profile %s already exists.	ERROR
digestLen = %d.	DEBUG	EAPAUTH_MALLOC failed	ERROR
ClearText =	DEBUG	User not found.	ERROR
CipherText =	DEBUG	EAP-MD5 not enabled in system configuration.	ERROR
digestLen = %d.	DEBUG	EAP-MSCHAPV2 not enabled in system configuration.	ERROR
digestLen1 = %d.	DEBUG	EAP-TLS not enabled in system configuration.	ERROR
digestLen2 = %d.	DEBUG	EAP-TTLS not enabled in system configuration.	ERROR

password change is not allowed for this user	DEBUG	EAP-PEAP not enabled in system configuration.	ERROR
completed writing the policy	DEBUG	EAP-WSC not enabled in system configuration.	ERROR
completed writing the SA	DEBUG	PAP not enabled in system configuration.	ERROR
completed writing the proposal block	DEBUG	CHAP not enabled in system configuration.	ERROR
cmdBuf: %s	DEBUG	MSCHAP not enabled in system configuration.	ERROR
X509_DEBUG : Invalid Certificate for the generated"	DEBUG	MSCHAPV2 not enabled in system configuration.	ERROR
X590_ERROR : Failed to create File '%s'	DEBUG	PAP/Token not enabled in system configuration.	ERROR
x509TbIHandler	DEBUG	EAP-MD5 not enabled in system configuration.	ERROR
pCertType: %s	DEBUG	EAP-MSCHAPV2 not enabled in system config.	ERROR
pRowQueryStr: %s	DEBUG	EAP-TLS not enabled in system configuration.	ERROR
x509SelfCertTbIHandler	DEBUG	EAP-TTLS and EAP-PEAP are not valid as inner"	ERROR
pRowQueryStr: %s	DEBUG	invalid innerAuth %d.	ERROR
%s:DBUpdate event: Table: %s opCode: %d rowId: %d	DEBUG	profile %s doesnt exist.	ERROR
umiRegister failed	ERROR	Re-assembling fragments incorrect size	ERROR
eapAuthHandler: Invalid data received	ERROR	Error creating cipher context.	ERROR
EAPAUTH_MALLOC failed.	ERROR	Error initializing cipher context.	ERROR
malloc failed.	ERROR	Error creating digest context.	ERROR
BIO_new_mem_buffailed.	ERROR	Error initializing digest context.	ERROR
malloc failed.	ERROR	Error initializing DES in Klite	ERROR
BIO_new_mem_buffailed.	ERROR	Error initializing MD4 in Klite	ERROR
SSL_CTX_new (TLSv1_client_method) failed.	ERROR	Error initializing RC4 in Klite	ERROR
unable to set user configured CIPHER list %s	ERROR	Error initializing SHA in Klite	ERROR
Certificate verification failed.	ERROR	Error cleaning cipher context.	ERROR
Server name match failed. Got (%s) expected "	ERROR	Error destroying cipher context.	ERROR
SSL_CTX_use_certificate_file (cert, PEM) failed.	ERROR	Error cleaning digest context.	ERROR
SSL_CTX_use_PrivateKey_file failed.	ERROR	Error destroying digest context.	ERROR
private key does not match public key	ERROR	Error stripping domain name.	ERROR
SSL_CTX_load_verify_locations failed	ERROR	Error cleaning digest context.	ERROR
SSL_new failed.	ERROR	Error cleaning digest context.	ERROR
Both SSL_VERIFY_PEER and SSL_VERIFY_NONE set: Error	ERROR	Challenge not present in failure packet.	ERROR
EAPAUTH_MALLOC failed.	ERROR	Wrong challenge length.	ERROR
EAPAUTH_MALLOC failed.	ERROR	Incorrect password change version value.	ERROR
eapTimerCreate failed.	ERROR	Error generating password hash.	ERROR
eapCtxDelete:pCtx == NULL	ERROR	Error generating password hash.	ERROR
eapRole != EAP_ROLE_PEER or EAP_ROLE_AUTHENTICATOR	ERROR	Error encrypting password hash with block	ERROR

pEapCtx == NULL or pPDU == NULL.	ERROR	Could not initialize des-ecb	ERROR
received EAP pdu bigger than EAP_MTU_SIZE.	ERROR	Error cleaning cipher context.	ERROR
received EAP pdu bigger than EAP_MTU_SIZE.	ERROR	Error cleaning cipher context.	ERROR
state machine is in invalid state.	ERROR	Error cleaning digest context.	ERROR
unable to create method context.	ERROR	Error cleaning digest context.	ERROR
method ctxCreate failed.	ERROR	adpDigestInit for SHA1 failed.	ERROR
method profile set failed.	ERROR	X509_ERROR : .Query:%s	ERROR
state machine is in invalid state.	ERROR	X509_ERROR : Invalid Certificate for the "	ERROR
Only StandAlone authenticator supported currently.	ERROR	invalid x509 certificate	ERROR
state machine is in invalid state.	ERROR	Couldn't get the x509 cert hash	ERROR
BuildReq operation failed	ERROR	Memory allocation failed	ERROR
No method ops defined for current method	ERROR	FileName too lengthy	ERROR
Process operation failed	ERROR	Couldn't execute command	ERROR
state machine is in invalid state.	ERROR	Memory allocation failed	ERROR
Packet length mismatch %d, %d	ERROR	Memory allocation failed	ERROR
eapAuthTypeToType: Invalid eapAuthType %d	ERROR	invalid certificate data	ERROR
eapTypeToAuthType: Invalid eapType %d	ERROR	.Query:%s	ERROR
unable to create method context.	ERROR	.Query:%s	ERROR
method ctxCreate failed.	ERROR	Memory allocation failed	ERROR
Invalid condition, methodState = %d, respMethod = %d	ERROR	X509_ERROR : Failed to validate the certificate "	ERROR
A EAP Ctx map already exists	ERROR	Memory allocation failed	ERROR
eapTimerCreate: Currently unsupported for Peer role	ERROR	.Query:%s	ERROR
eapTimerStart: Currently unsupported for Peer role	ERROR	Invalid Sign Key Length : %d	ERROR
eapTimerDestroy: Currently unsupported for Peer role	ERROR	Invalid Hash Alg : %d	ERROR
eapTimerCancel: Currently unsupported for Peer role	ERROR	Invalid Sign Alg : %d	ERROR
eapTimerHandler: Currently unsupported for Peer role	ERROR	No Memory Available	ERROR
pCtx is NULL: ERROR	ERROR	Certificate Request Failed	ERROR
tlsGlueCtxCreate failed	ERROR	File Open Failed	ERROR
eapVars is NULL	ERROR	File is Empty	ERROR
Context NULL: ERROR	ERROR	Memory Allocation Failed	ERROR
Initializing inner EAP auth: ERROR	ERROR	File Open Failed	ERROR
pCtx is NULL: ERROR	ERROR	File is Empty	ERROR
Memory Allocation Failed	ERROR	Error in executing DB update handler	ERROR

**Facility: System (Admin)**

Log Message	Severity	Log Message	Severity
Usage:%s <DBFile>	DEBUG	unable to register to UMI	ERROR



Could not open database: %s	DEBUG	sqlite3QueryResGet failed	ERROR
CPU LOG File not found	DEBUG	radSendtoServer: socket: %s	ERROR
MEM LOG File not found	DEBUG	radSendtoServer: bind() Failed: %s: %s	ERROR
cpuMemUsageDBUpdateHandler: update query: %s	DEBUG	radRecvfromServer: recvfrom() Failed: %s	ERROR
Printing the whole list after inserting	DEBUG	radRecvfromServer: Packet too small from %s:%d: %s	ERROR
%s at %d(minute) %d(hour) %d(dayOfMonth) %d(month)"	DEBUG	radCheckMsgAuth: Invalid Message- Authenticator length in"	ERROR
adpCmdExec exited with return code=%d	DEBUG	radDictLoad: couldn't open dictionary %s: %s	ERROR
%s op=%d row=%d	DEBUG	radBuildAndSendReq: Invalid Request Code %d	ERROR
sqlite3_mprintf failed	DEBUG	radPairAssign: bad attribute value length	ERROR
sqlite3QueryResGet failed: query=%s	DEBUG	radPairAssign: unknown attribute type %d	ERROR
Printing the whole list after delete	DEBUG	radPairNew: unknown attribute %d	ERROR
%s at %d(minute) %d(hour) %d(dayOfMonth) %d(month)"	DEBUG	radPairGen: Attribute(%d) has invalid length	ERROR
Printing the whole list after inserting	DEBUG	radPairValue: unknown attribute type %d	ERROR
%s at %d(minute) %d(hour) %d(dayOfMonth) %d(month)"	DEBUG	radPairValueLen: unknown attribute type %d	ERROR
email logs: No logging events enabled	DEBUG	radPairLocate: Attribute(%d) has invalid length	ERROR
%s	DEBUG	radPairUnpackDefault: Unknown- Attribute[%d]:	ERROR
Mail sent and the Database is reset.	DEBUG	radConfigure: can't open %s: %s	ERROR
Disabled syslog server	DEBUG	radConfigure: %s: line %d: bogus format: %s	ERROR
Event logs are full, sending logs to email	DEBUG	radConfAssert: No AuthServer Specified	ERROR
Email logs sending failed	DEBUG	radConfAssert: No Default Timeout Specified	ERROR
Packing attribute: %s	DEBUG	radConfAssert: No Default Retry Count Specified	ERROR
Server found: %s, secret: %s	DEBUG	radExtractMppeKey: Invalid MS- MPPE-Key Length	ERROR
Packed Auth. Request: code:%d, id:%d, len:%d	DEBUG	radVendorMessage: Invalid Length in Vendor Message	ERROR
Sending Packet to %x:%d ....	DEBUG	radVendorMessage: Unknown Vendor ID received:%d	ERROR
Receiving Reply Packet...	DEBUG	radVendorAttrGet: Invalid Length in Vendor Message	ERROR
Verified Reply Packet Integrity	DEBUG	radVendorAttrGet: Unknown Vendor ID:%d	ERROR
Generated Reply Attribute-Value pairs	DEBUG	radVendorMessagePack: Unknown Vendor ID:%d	ERROR
Verified Message-Authenticator	DEBUG	radGetIPByName: couldn't resolve hostname: %s	ERROR
Unloaded RADIUS Dictionary	DEBUG	radGetHostIP: couldn't get hostname	ERROR
Adding Dictionary Attribute %s	DEBUG	radGetHostIP: couldn't get host IP address	ERROR
Adding Dictionary Value %s	DEBUG	radius dictionary loading failed	ERROR
Loaded Dictionary %s	DEBUG	Failed to set default timeout value	ERROR

Adding Dictionary Attribute '%s'	DEBUG	Failed to set default retries value	ERROR
Adding Dictionary Value %s	DEBUG	ERROR: incomplete DB update information.	ERROR
Receiving attribute: %s	DEBUG	old values result does not contain 2 rows	ERROR
Processing attribute: %s	DEBUG	sqlite3QueryResGet failed	ERROR
Processing attribute: %s	DEBUG	empty update. nRows=%d nCols=%d	ERROR
Processing attribute: %s	DEBUG	Error in executing DB update handler	ERROR
Processing attribute: %s	DEBUG	sqlite3QueryResGet failed	ERROR
radConfGet: "	DEBUG	Invalid SQLITE operation code - %d	ERROR
Added Server %s:%d with "	DEBUG	sqlite3QueryResGet failed	ERROR
Added Server %s:%d with "	DEBUG	empty result. nRows=%d nCols=%d	ERROR
Default Timeout Set to %d	DEBUG	sqlite3QueryResGet failed	ERROR
Default Retry Count Set to %d	DEBUG	empty result. nRows=%d nCols=%d	ERROR
%s - %s : %d	DEBUG	RADIUS Accounting Exchange Failed	ERROR
Deleting Server %s:%d with "	DEBUG	Unable to set debug for radAcct.	ERROR
Adding RowId:%d to Server %s:%d with "	DEBUG	Unable to set debug level for radAcct.	ERROR
rowIds: %d - %d	DEBUG	ERROR: option value not specified	ERROR
Deleting Server %s:%d with "	DEBUG	ERROR: option value not specified	ERROR
RADIUS Deconfigured	DEBUG	Unable to initialize radius	ERROR
Found Option %s on line %d of file %s	DEBUG	radEapMsgQueueAdd: Invalid EAP packet length(%d)	ERROR
Setting Option %s with value %s	DEBUG	radEapRecvTask: invalid EAP code:%d	ERROR
RADIUS Configured	DEBUG	radEapRecvTask: Packet length mismatch %d, %d	ERROR
%d : Server %s:%d with "	DEBUG	No attributes received in Access-Challenge message	ERROR
DBUpdate event: Table: %s opCode:%d rowId:%d	DEBUG	No State Attribute in Access-Challenge message	ERROR
Host IP address: %s	DEBUG	radEapRecvTask: "	ERROR
Adding Packet for existing cookie:%p	DEBUG	failed to initialize UMI	ERROR
Adding Packet and cookie:%p	DEBUG	umiRegister failed. errno=%d	ERROR
Releasing Packet and cookie:%p	DEBUG	Invalid arguments to ioctl handler	ERROR
Releasing Packet with cookie:%p	DEBUG	radEapSendRtn: Invalid Arguments	ERROR
Received EAP-Identity from Pnac: %s	DEBUG	radEapSendRtn: failed to allocate buffer	ERROR
Filling User-Name: %s	DEBUG	umioctl failed	ERROR
Filling State:	DEBUG	failed to initialize EAP message queue	ERROR
Filling EAP-Message:	DEBUG	Unable to set debug for radEap.	ERROR
Filling Service-Type: %d	DEBUG	Unable to set debug level for radEap.	ERROR
Filling Framed-MTU: %d	DEBUG	ERROR: option value not specified	ERROR
Received Access-Challenge from Server	DEBUG	ERROR: option value not specified	ERROR
Sending Reply EAP Packet to Pnac	DEBUG	could not initialize MGMT framework	ERROR
Error sending packet to Pnac	DEBUG	Unable to initialize radius	ERROR
RADIUS Authentication Failed; "	DEBUG	Unable to set debug for radEap.	ERROR
RADIUS Authentication Successful; "	DEBUG	Unable to set debug level for radEap.	ERROR
Got Packet with cookie:%p	DEBUG	ERROR: option value not specified	ERROR
Next DNS Retry after 1 min	DEBUG	Unable to initialize radius	ERROR
Next Synchronization after"	DEBUG	Invalid username or password	ERROR

Next Synchronization after"	DEBUG	Unable to set debug for radAuth.	ERROR
Next Synchronization after %d \	DEBUG	Unable to set debug level for radAuth.	ERROR
Primary is not available, "	DEBUG	ERROR: option value not specified	ERROR
Secondary is not available, "	DEBUG	Unable to initialize radius	ERROR
Invalid value for use default servers, "	DEBUG	Invalid username, challenge or response	ERROR
No server is configured, "	DEBUG	Unable to set debug for radAuth.	ERROR
Backing off for %d seconds	DEBUG	Unable to set debug level for radAuth.	ERROR
Requesting time from %s	DEBUG	ERROR: option value not specified	ERROR
Synchronized time with %s	DEBUG	Unable to initialize radius	ERROR
Received KOD packet from %s	DEBUG	Invalid username or password	ERROR
No suitable server found %s	DEBUG	usage : %s <DB fileName>	ERROR
Received Invalid Length packet from %s	DEBUG	ntpd : umi initialization failed	ERROR
Received Invalid Version packet from %s	DEBUG	ntpd : ntpInit failed	ERROR
Received Invalid Mode packet from %s	DEBUG	ntpd : ntpMgmtInit failed	ERROR
Request Timed out from %s	DEBUG	There was an error while getting the timeZoneChangeScript."	ERROR
Looking Up %s	DEBUG	unexpected reply from %d cmd=%d !	ERROR
Timezone difference :%d	DEBUG	cmd %d not supported. caller %d	ERROR
Could not open file: %s	DEBUG	default reached	ERROR
Could not read data from file	DEBUG	Unable to initialize ntpControl	ERROR
ntpTblHandler	DEBUG	ntpMgmt : Couldn't open database %s	ERROR
status: %d	DEBUG	ERROR : incomplete DB update information	ERROR
tz: %d	DEBUG	empty update. nRows=%d nCols=%d	ERROR
DayLightSaving: %d	DEBUG	Error in executing DB update handler	ERROR
pNtpControl->ServerNames[PRIMARY_SERVER]: %s	DEBUG	requestNtpTime: Invalid addr	ERROR
pNtpControl->ServerNames[SECONDARY_SERVER] : %s	DEBUG	failed to take lock for compld: %d failed to convert ioctl args to buffer for"	ERROR
DS: %d	DEBUG	request timeout dst(%d) <-- src(%d)	ERROR
pPriServ %s	DEBUG	failed to take lock for compld: %d	ERROR
pSecServ %s	DEBUG	umiloctlArgs ToBuf: failed to allocate memory	ERROR
Making request from %d --> %d	DEBUG	umirecvFrom: could not allocate memory	ERROR
sent request dst(%d) <-- src(%d) using option %d	DEBUG	adpMalloc failed	ERROR
received request too small!(%d bytes)	DEBUG	context with ID: %d already registered	ERROR
Received a UMI request from %d	DEBUG	Failed to allocate memory for creating UMI context	ERROR
sent a reply src(%d) ---> dst(%d)	DEBUG	Failed to create recvSem for UMI context	ERROR
umiRegister (%x,%x,%x,%x)	DEBUG	Failed to create mutex locks for UMI context	ERROR
srcId=%d(%s) --> destId=%d(%s) cmd=%d inLen=%d outLen=%d	DEBUG	Failed to create mutex recvQLock for UMI context	ERROR
waiting for reply...Giving Up	DEBUG	Invalid arguments to umiloctl	ERROR
No request in the list after semTake	DEBUG	could not find the destination context	ERROR
reply timeout	DEBUG		ERROR

timeout after semTake	DEBUG	memPartAlloc for %d size failed	ERROR
srcId=%d(%s) <-- destId=%d(%s) cmd=%d	DEBUG	memPartAlloc for %d size failed	ERROR
Un-registering component with Id %d	DEBUG	No Handler registered for this UMI context	ERROR
failed to send ioctl request: dst(%d) <--- src(%d)	DEBUG	Couldn't find component with ID (%d),"	ERROR
processed a reply dst(%d) <-- src(%d)	DEBUG	id=%d handler=%x	ERROR
request with no result option dst(%d) <--- src(%d)	DEBUG	Received NULL buffer in umiBufToIoctlArgs()	ERROR
cmd = %s	DEBUG	usbMgmtInit: unable to open the database file %s	ERROR
cmdstring is %s %s:%d	DEBUG	call to printConfig failed	ERROR
Calling printerConfig binary...	DEBUG	Failed to Disable Network Storage"	ERROR
Calling unmount for USB ...	DEBUG	Some error occurred while removing device	ERROR
Calling mount for USB ...	DEBUG	Some error occurred while removing device	ERROR
usbdevice is %d %s:%d	DEBUG	Sqlite update failed	ERROR
Query string: %s	DEBUG	Failed to enable printer properly	ERROR
sqlite3QueryResGet failed. Query: %s	DEBUG	Failed to mount device on system	ERROR
%s: 1. usb is already disconnected for old usb type. "	DEBUG	Failed to enable network storage device"	ERROR
%s: 2. call disable for new usb type !	DEBUG	Failed to mount device on system	ERROR
%s: 3. usb is already disconnected for old usb type. "	DEBUG	Sqlite update failed	ERROR
%s: 4. Disabled old usb type . Now "	DEBUG	USB1 Touch failed	ERROR
usbdevice is %d %s:%d	DEBUG	USB2 Touch failed	ERROR
USB: failed to begin transaction: %s	DEBUG	Sqlite update failed	ERROR
USB: SQL error: %s pSetString = %s	DEBUG	Failed query: %s	ERROR
USB: failed to commit transaction: %s	DEBUG	Failed to execute usb database update handler	ERROR
USB: updated table: %s	DEBUG	Usage: %s <DBFile> <opType> <tblName> <rowId>	ERROR
USB: returning with status: %s	DEBUG	Illegal invocation of snmpConfig (%s)	ERROR
%s: DBUpdate event: Table: %s opCode: %d rowId: %d	DEBUG	Invalid Community Access Type	ERROR
executing %s status = %d	DEBUG	Invalid User Access Type	ERROR
executing %s	DEBUG	Invalid Security Level	ERROR
%s returned status = %d	DEBUG	Invalid Authentication Algorithm	ERROR
%s returned status = %d	DEBUG	Invalid Privacy Algorithm	ERROR
snmpd.conf not found	DEBUG	Invalid Argument	ERROR
[SNMP_DEBUG] : Fwrite Successful	DEBUG	Failed to allocate memory for engineID	ERROR
[SNMP_DEBUG] : Fwrite failed	DEBUG	[SNMP_DEBUG]: Failed to get host address	ERROR
radPairGen: received unknown attribute %d of length %d	WARN	[SNMP_DEBUG] : FOPEN failed	ERROR
radPairGen: %s has unknown type	WARN	sqlite3QueryResGet failed. Query: %s	ERROR
radPairLocate: unknown attribute %d of length %d	WARN	sqlite3QueryResGet failed. Query: %s	ERROR
radPairLocate: %s has unknown type	WARN	Invalid Security Level	ERROR
Illegal invocation of cpuMemUsage (%s)	ERROR	Invalid Authentication Algorithm	ERROR

cpuMemUsageDBUpdateHandler: SQL error: %s	ERROR	Invalid Privacy Algorithm	ERROR
unable to open the DB file %s	ERROR	Failed to Get Host Address	ERROR
umilnit failed	ERROR	Invalid version	ERROR
unable to register to UMI	ERROR	snmp v3 Trap Configuration Failed	ERROR
Error Reading from the Database.	ERROR	sqlite3QueryResGet failed query:%s	ERROR
short DB update event request!	ERROR	sqlite3QueryResGet failed.Query:%s	ERROR
Error in executing DB update handler	ERROR	Failed to Open Snmp Configuration File	ERROR
adpListNodeRemove : Returned with an error	ERROR	Failed to write access control entries	ERROR
command too long. Try increasing "	ERROR	Failed to write snmpv3 users entries	ERROR
failed to allocate memory for CRON_NODE	ERROR	Failed to write snmp trap entries	ERROR
sqlite3QueryResGet failed	ERROR	Failed to write system entries.	ERROR
There was an error while reading the schedules.	ERROR	Failed to restart snmp	ERROR
unable to register to UMI	ERROR	%s failed with status	ERROR
short DB update event request!	ERROR	Error in executing DB update handler	ERROR
malloc(DB_UPDATE_NODE) failed	ERROR	%s: Unable to open file: %s	ERROR
short ifDev event request!	ERROR	RADVD start failed	ERROR
sqlite3_mprintf failed	ERROR	RADVD stop failed	ERROR
no component id matching %s	ERROR	failed to create/open RADVD configuration file %s	ERROR
umiloctl (%s, UMI_CMD_DB_UPDATE(%d)) failed.	ERROR	Restoring old configuration..	ERROR
sqlite3_mprintf failed	ERROR	failed to write/update RADVD configuration file	ERROR
sqlite3_mprintf failed	ERROR	upnpDisableFunc failed	ERROR
no component id matching %s	ERROR	upnpEnableFunc failed	ERROR
umiloctl (%s, UMI_CMD_IFDEV_EVENT(%d)) failed.	ERROR	sqlite3QueryResGet failed.Query:%s	ERROR
klogctl(9) failed	ERROR	Error in executing DB update handler	ERROR
malloc failed for %d bytes	ERROR	unable to open the DB file %s	ERROR
klogctl(4) failed	ERROR	umilnit failed	ERROR
emailLogs: Invalid Number of Arguments!! Exiting.	ERROR	unable to register to UMI	ERROR
sqlite3QueryResGet failed	ERROR	short DB update event request!	ERROR
Could not execute the smtpClient.	ERROR	short ifDev event request!	ERROR
Error while cleaning the database.Exiting. %s	ERROR	sqlite3_mprintf failed	ERROR
		%s failed. status=%d	ERROR

**Facility: System (Firewall)**

Log Message	Severity	Log Message	Severity
Enabling rule for protocol binding.	DEBUG	Disable all NAT rules.	DEBUG
Disabling rule for protocol binding.	DEBUG	Enable all NAT rules.	DEBUG
Enabling Remote SNMP on WAN.	DEBUG	Enabling NAT URL filter rules.	DEBUG
Disabling Remote SNMP on WAN	DEBUG	Restarting all NAT rules.	DEBUG

wan traffic counters are restarted	DEBUG	Deleting schedule based firewall rules.	DEBUG
Traffic limit has been reached	DEBUG	Deleting schedule based firewall rules from DB.	DEBUG
Traffic meter monthly limit has been changed to %d.	DEBUG	Update schedule based firewall rules in DB.	DEBUG
Enabling traffic meter for only download.	DEBUG	Restart schedule based firewall rules.	DEBUG
Enabling traffic meter for both directions.	DEBUG	inter vlan routing enabled	DEBUG
Enabling traffic meter with no limit.	DEBUG	inter vlan routing disabled	DEBUG
Email alert in traffic meter disabled.	DEBUG	Disabling Content Filter for %d	DEBUG
Email alert in traffic meter enabled.	DEBUG	Enabling Content Filter for %d	DEBUG
Traffic Meter: Monthly limit %d MB has been "	DEBUG	./src/firewall/linux/user/firewalld.c:59:#undef ADP_DEBUG2	DEBUG
Traffic Metering: Adding rule to drop all traffic	DEBUG	./src/firewall/linux/user/firewalld.c:61:#define ADP_DEBUG2 printf	DEBUG
Traffic Metering: %sabling Email traffic	DEBUG	Enabling Source MAC Filtering	DEBUG
Disabling attack checks for IPv6 rules.	DEBUG	Disabling Source MAC Filtering	DEBUG
Enabling attack checks for IPv6 rules.	DEBUG	Adding MAC Filter Policy for Block & Permit Rest	DEBUG
Configuring one to one NAT settings with %s private start IP "	DEBUG	Adding MAC Filter Policy for Permit & Block Rest	DEBUG
Deleting forward one to one NAT having setting %s private start"	DEBUG	Restarting Source MAC Address Policy	DEBUG
Disabling attack check for Block ping to WAN interface.	DEBUG	Disabling Firewall Rule for DHCP Relay Protocol	DEBUG
Disabling attack check for Stealth mode for tcp	DEBUG	Enabling Firewall Rule for DHCP Relay Protocol	DEBUG
Disabling attack check for Stealth mode for udp	DEBUG	pre-routing Firewall Rule add for Relay failed	DEBUG
Disabling attack check for TCP Flood.	DEBUG	pre-routing Firewall Rule add for Relay failed	DEBUG
Disabling attack check for UDP Flood.	DEBUG	Deleting MAC Filter Policy for Address %s	DEBUG
Disabling attack check for IPsec.	DEBUG	Adding MAC Filter Policy for Address %s	DEBUG
Disabling attack check for PPTP.	DEBUG	Disabling Firewall Rules for DMZ host	DEBUG
Disabling attack check for L2TP.	DEBUG	Enabling Firewall Rules for DMZ host	DEBUG
Disabling attack check for UDP Flood.	DEBUG	Disabling Firewall Rules for Spill Over Load Balancing	DEBUG
Disabling attack check for IPsec.	DEBUG	Disabling Firewall Rules for Load Balancing	DEBUG
Disabling attack check for PPTP.	DEBUG	Enabling Firewall Rules for Load Balancing	DEBUG
Disabling attack check for L2TP.	DEBUG	Enabling Firewall Rules for Spill Over Load Balancing	DEBUG
Enabling attack check for Block ping to WAN "	DEBUG	Enabling Firewall Rules for Auto Failover	DEBUG
Enabling attack check for Stealth Mode for tcp.	DEBUG	Enabling Firewall Rules for Load Balancing .	DEBUG
Enabling attack check for Stealth Mode for udp.	DEBUG	Enabling Firewall Rules for Spill Over Load Balancing .	DEBUG
Enabling attack check for TCP Flood.	DEBUG	Enabling Firewall Rules for Auto Failover	DEBUG
Enabling attack check for UDP Flood.	DEBUG	Deleting BlockSites Keyword \	DEBUG
Enabling attack check for IPsec.	DEBUG	Enabling BlockSites Keyword \	DEBUG
Enabling attack check for PPTP.	DEBUG	Disabling BlockSites Keyword \	DEBUG

Enabling attack check for L2TP.	DEBUG	Updating BlockSites Keyword from \	DEBUG
Enabling attack check for UDP Flood.	DEBUG	Inserting BlockSites Keyword \	DEBUG
Enabling attack check for IPsec.	DEBUG	Deleting Trusted Domain \	DEBUG
Enabling attack check for PPTP.	DEBUG	Adding Trusted Domain \	DEBUG
Enabling attack check for L2TP.	DEBUG	Restarting Schedule Based Firewall Rules	DEBUG
Enabling DoS attack check with %d SyncFlood detect rate, "	DEBUG	Enabling Remote SNMP	DEBUG
Disabling DoS attack check having %d SyncFlood detect rate,"	DEBUG	Disabling Remote SNMP	DEBUG
Enabling ICSA Notification Item for ICMP notification.	DEBUG	Enabling Remote SNMP	DEBUG
Enabling ICSA Notification Item for Fragmented Packets.	DEBUG	Disabling DOS Attacks	DEBUG
Enabling ICSA Notification Item for Multi cast Packets.	DEBUG	Enabling DOS Attacks	DEBUG
Disabling ICSA Notification Item for ICMP notification.	DEBUG	Enabling DOS Attacks	DEBUG
Disabling ICSA Notification Item for Fragmented Packets.	DEBUG	Restarting Firewall [%d]:[%d] For %s	DEBUG
Disabling ICSA Notification Item for Multi cast Packets.	DEBUG	restartStatus = %d for LogicalIfName = %s	DEBUG
Adding IP/MAC binding rule for %s MAC address "	DEBUG	Deleting Lan Group %s	DEBUG
Deleting IP/MAC binding rule for %s MAC "	DEBUG	Adding Lan Group %s	DEBUG
./src/firewall/linux/user/firewalld.c:60:#undef ADP_DEBUG	DEBUG	Deleting lan host %s from group %s	DEBUG
./src/firewall/linux/user/firewalld.c:62:#define ADP_DEBUG printf	DEBUG	Adding lan host %s from group %s	DEBUG
Restarting traffic meter with %d mins, %d hours, "	DEBUG	Disabling Firewall Rule for IGMP Protocol	DEBUG
Updating traffic meter with %d mins, %d hours, "	DEBUG	Enabling Firewall Rule for IGMP Protocol	DEBUG
Deleting traffic meter.	DEBUG	Deleting IP/MAC Bind Rule for MAC address %s and IP "	DEBUG
Disabling block traffic for traffic meter.	DEBUG	Adding IP/MAC Bind Rule for MAC address %s and IP	DEBUG
Enabling traffic meter.	DEBUG	Deleting Protocol Bind Rule for Service %s	DEBUG
Adding lan group %s.	DEBUG	Deleting Protocol Bind Rule for Service %s	DEBUG
Deleting lan group %s.	DEBUG	Deleting Protocol Bind Rule for Service %s	DEBUG
Renaming lan group from %s to %s.	DEBUG	Adding Protocol Bind Rule for Service %s	DEBUG
Deleting host %s from %s group.	DEBUG	%s Session Settings	DEBUG
Adding host %s to %s group.	DEBUG	Restarting IPv6 Firewall Rules...	DEBUG
Enabling Keyword blocking for %s keyword.	DEBUG	Deleting Port Trigger Rule for %d:%d:%d:%d	DEBUG
Disabling keyword Blocking for %s keyword .	DEBUG	Deleting Port Trigger Rule for %d:%d:%d:%d	DEBUG
Deleting trusted domain with keyword %s.	DEBUG	Enabling Port Trigger Rule for %d:%d:%d:%d	DEBUG
Adding %s keyword to trusted domain.	DEBUG	Disabling Port Trigger Rule for %d:%d:%d:%d	DEBUG
Enabling Management Access from	DEBUG	Enabling Port Trigger Rule for	DEBUG

Internet on port %d		%d:%d:%d:%d	
Enabling remote access management for IP address range"	DEBUG	Disabling Port Trigger Rule for %d:%d:%d:%d	DEBUG
Enabling remote access management to only this PC.	DEBUG	Adding Port Trigger Rule for %d:%d:%d:%d	DEBUG
Disabling Management Access from Internet on port %d	DEBUG	Enabling Content Filter	DEBUG
Disabling remote access management for IP address range"	DEBUG	Disabling Content Filter	DEBUG
Disabling remote access management only to this PC.	DEBUG	Enabling Content Filter	DEBUG
MAC Filtering %sabled for BLOCK and PERMIT REST.	DEBUG	Setting NAT mode for pLogicallyName = %s	DEBUG
MAC Filtering %sabled for PERMIT and BLOCK REST.	DEBUG	Enabling DROP for INPUT	DEBUG
Enabling Content Filtering.	DEBUG	Enabling DROP for FORWARD	DEBUG
Disabling Content Filtering.	DEBUG	Enabling NAT based Firewall Rules	DEBUG
Deleting rule, port triggering for protocol TCP.	DEBUG	Setting transparent mode for pLogicallyName \	DEBUG
Deleting rule, port triggering for protocol UDP.	DEBUG	Enabling Accept for INPUT	DEBUG
Deleting rule, port triggering for protocol TCP.	DEBUG	Enabling Accept for FORWARD	DEBUG
Deleting rule, port triggering for protocol UDP.	DEBUG	Setting Routing mode for pLogicallyName \	DEBUG
Enabling rule, port triggering for protocol TCP.	DEBUG	Enabling DROP for INPUT	DEBUG
Enabling rule, port triggering for protocol UDP.	DEBUG	Enabling DROP for FORWARD	DEBUG
Enabling rule, port triggering for protocol TCP.	DEBUG	Disabling NAT based Firewall Rules	DEBUG
Enabling rule, port triggering for protocol UDP.	DEBUG	Enabling Firewall Rules for URL Filtering & "	DEBUG
Enabling DNS proxy.	DEBUG	Adding Firewall Rule for RIP Protocol	DEBUG
Restarting DNS proxy.	DEBUG	Restarting Schedule Based Firewall Rules	DEBUG
checking DNS proxy for Secure zone.	DEBUG	enabling IPS checks between %s and %s zones.	DEBUG
checking DNS proxy for Public zone.	DEBUG	disabling IPS checks between %s and %s zones.	DEBUG
Enabling Block traffic from %s zone.	DEBUG	Stopping IPS...%s	DEBUG
Configuring firewall session settings for "	DEBUG	IPS started.	DEBUG
Disabling DMZ	DEBUG	Route already exists	DEBUG
Disabling WAN-DMZ rules .	DEBUG	Route addition failed: Network Unreachable	DEBUG
Enabling WAN DMZ rules .	DEBUG	Route addition failed: Network is down	DEBUG
Restarting DMZ rule having %s address with %s address.	DEBUG	Route addition failed	DEBUG
Enabling LAN DHCP relay.	DEBUG	Failed to add rule in iptables	DEBUG
OneToOneNat configured successfully	DEBUG	Failed to delete rule from iptables	DEBUG
OneToOneNat configuration failed	DEBUG	fwLBSpillOverConfigure: Something going wrong here	ERROR
Deleting scheduled IPv6 rules.	DEBUG	fwLBSpillOverConfigure: unable to get interfaceName	ERROR
delete from FirewallRules6 where ScheduleName = '%s'.	DEBUG	fwLBSpillOverConfigure: Could not set PREROUTING rules	ERROR



Update FirewallRules6 where ScheduleName = '%s' to New "	DEBUG	fwLBSpillOverConfigure: Could not set POSTROUTING rules	ERROR
Dns proxy Restart failed	DEBUG	fwLBSpillOverConfigure: Something going wrong Here	ERROR
deleting interface to ifgroup failed	DEBUG	fwL2TPGenericRules.c: unable to open the database file "	ERROR
adding interface to ifgroup failed	DEBUG	fwL2TPGenericRules.c: inet_aton failed	ERROR
deleting interface pVirtiface %s from ifgroup %d"	DEBUG	fwPPTPGenericRules.c: unable to open the database file "	ERROR
adding interface pVirtiface %s to ifgroup %d failed	DEBUG	fwPPTPGenericRules.c: inet_aton failed	ERROR
Deleting IP address %s.	DEBUG	DNS proxy firewall rule add failed for %s	ERROR
Adding new IP address %s.	DEBUG	deleting interface %s from ifgroup %d failed	ERROR
Updating old IP address %s to new IP address %s.	DEBUG	adding interface %s to ifgroup %d failed	ERROR
Restarting Firewall For %s Address Update from %s:%s	DEBUG	nimfBridgeTblHandler: unable to get interfaceName	ERROR
Disabling Firewall Rule for MSS packet marking	DEBUG	nimfBridgeTblHandler: \	ERROR
Enabling Firewall Rule for MSS packet marking	DEBUG	nimfBridgeTblHandler: unable to get \	ERROR
Enabling packet marking rule for %s IDLE timer	DEBUG	Failed to %s traffic from %s to %s to IPS.	ERROR
Deleted firewall rule %s for service %s with action %s	DEBUG	Failed to %s traffic from %s to %s to IPS.	ERROR
%s firewall rule %s for service %s with action %s	DEBUG	failed to start IPS service.	ERROR
Added firewall rule %s for service %s with action %s	DEBUG	Timeout in waiting for IPS service to start.	ERROR
Deleting inbound(WAN-LAN) firewall rule.	DEBUG	Usage:%s <DBFile> <opType> <tblName> <rowId> "	ERROR
Deleting inbound(WAN-DMZ) firewall rule.	DEBUG	xlr8NatConfig: illegal invocation of (%s)	ERROR
RIPng disabled.	DEBUG	Illegal invocation of [%s]	ERROR
RIPng enabled.	DEBUG	xlr8NatMgmtTblHandler: failed query: %s	ERROR
Disable IPv6 firewall rule.	DEBUG	Could not open file: %s	ERROR
Enable IPv6 firewall rule.	DEBUG	Rip Error Command Too Long	ERROR
Deleting IGMP proxy rule.	DEBUG	No authentication for Ripv1	ERROR
Enable IGMP proxy rule.	DEBUG	Invalid Rip Direction	ERROR
Restarting IGMP rule.	DEBUG	Invalid Rip Version	ERROR
Traffic meter enabled with no limit type.	DEBUG	Invalid Password for 1st Key	ERROR
Traffic meter enabled for only download.	DEBUG	Invalid Time for 1st Key	ERROR
Traffic meter enabled for both directions.	DEBUG	Invalid Password for 2nd Key	ERROR
Deleted firewall rule %s for service %s with action %s	DEBUG	Invalid Time for 2nd Key	ERROR
%s firewall rule %s for service %s with action %s	DEBUG	Invalid First KeyId	ERROR
Added firewall rule %s for service %s with action %s	DEBUG	Invalid Second KeyId	ERROR
Enabling Inter VLAN routing.	DEBUG	Invalid Authentication Type	ERROR
Updating inter VLAN routing status.	DEBUG	ripDisable failed	ERROR
Deleting inter VLAN routing.	DEBUG	ripEnable failed	ERROR

**Facility: Local0 (Wireless)**

Log Message	Severity	Log Message	Severity
(node=%s) setting %s to val = %d	DEBUG	sqlite3QueryResGet failed	ERROR
Custom wireless event: '%s'	DEBUG	sqlite3QueryResGet failed	ERROR
Wireless event: cmd=0x%x len=%d	DEBUG	VAP(%s) set beacon interval failed	ERROR
New Rogue AP (%02x:%02x:%02x:%02x:%02x:%02x) detected	DEBUG	VAP(%s) set DTIM interval failed	ERROR
WPS session in progress, ignoring enrolle assoc request	DEBUG	VAP(%s) set RTS Threshold failed	ERROR
ran query %s	DEBUG	VAP(%s) set Fragmentation Threshold failed	ERROR
DBUpdate event: Table: %s opCode:%d rowId:%d	DEBUG	VAP(%s) set Protection Mode failed	ERROR
%sing VAPs using profile %s	DEBUG	VAP(%s) set Tx Power failed	ERROR
%sing VAP %s	DEBUG	WDS Profile %s not found	ERROR
ran query %s	DEBUG	Failed to initialize WPS on %s	ERROR
%sing VAP instance %s	DEBUG	failed to get profile %s	ERROR
VAP(%s) set Short Preamble failed	DEBUG	could not initialize MGMT framework	ERROR
VAP(%s) set Short Retry failed	DEBUG	could not initialize MGMT framework	ERROR
VAP(%s) set Long Retry failed	DEBUG	dot11 VapBssidUpdt SQL error: %s	ERROR
Decrypting context with key %s	DEBUG	sqlite3QueryResGet failed.Query:%s KDOT11_GET_PARAM(IEEE80211_I OC_CHANNEL) failed	ERROR
Unknown IAPP command %d received.	DEBUG	Failed to get the channel setting for %s	ERROR
unexpected reply from %d cmd=%d!	DEBUG	sqlite3QueryResGet failed.Query:%s	ERROR
unexpected reply from %d cmd=%d!	DEBUG	sqlite3QueryResGet failed.Query:%s	ERROR
Recvied DOT11_EAPOL_KEYMSG	DEBUG	sqlite3QueryResGet failed.Query:%s	ERROR
shutting down AP:%s	DEBUG	profile %s not found	ERROR
APCtx Found	DEBUG	sqlite3QueryResGet failed.Query:%s	ERROR
APCtx Not-Found	DEBUG	Interface name and policy must be specified	ERROR
node not found *:*:%x:%x:%x	DEBUG	Interface name and policy must be specified	ERROR
error installing unicast key for %s	DEBUG	invalid ACL type %d	ERROR
cmd =%d i_type =%d i_val=%d	DEBUG	interface name not specified	ERROR
join event for new node %s	DEBUG	interface name not specified	ERROR
wpa/rsn IE id %d/%d not supported	DEBUG	Invalid interface - %s specified	ERROR
wpa IE id %d not supported	DEBUG	buffer length not specified	ERROR
leave event for node %s	DEBUG	Invalid length(%d) specified	ERROR
NodeFree request for node : %s	DEBUG	failed created iappdLock	ERROR
installing keyto index %d	DEBUG	failed to create cipher contexts.	ERROR
iReq.i_val : %d	DEBUG	unable to register to UMI	ERROR
plfName : %s	DEBUG	iappSocklnit() failed	ERROR
iReq.i_val : %d	DEBUG	iapplnit got error, unregistering it with UMI	ERROR
setting mode: %d	DEBUG	umiloctl(UMI_COMP_UDOT11,%d,%d ) failed	ERROR
Global counter wrapped, re-generating...	DEBUG	umiloctl(UMI_COMP_KDOT11,%d,%d ) failed	ERROR

Got PNAC_EVENT_PREAUTH_SUCCESS event for : %s	DEBUG	UDP failed, received Length is %d	ERROR
event for non-existent node %s	DEBUG	umiloctl(UMI_COMP_KDOT11,	ERROR
PNAC_EVENT_EAPOL_START event received	DEBUG	umiloctl(UMI_COMP_UDOT11,%d,%d) \	ERROR
PNAC_EVENT_EAPOL_LOGOFF event received	DEBUG	umiloctl(UMI_COMP_KDOT11,%d,%d) \	ERROR
PNAC_EVENT_REAUTH event received	DEBUG	No IAPP Node found for req id %d	ERROR
PNAC_EVENT_AUTH_SUCCESS event received	DEBUG	umiloctl(UMI_COMP_UDOT11,%d,%d) \	ERROR
PNAC_EVENT_PORT_STATUS_CHAN GED event received	DEBUG	umiloctl(UMI_COMP_KDOT11,%d,%d) \	ERROR
unsupported event %d from PNAC event for non-existent node %s. Create new node.	DEBUG	umiloctl(UMI_COMP_UDOT11,%d,%d) failed	ERROR
Add new node to DOT11 Node list	DEBUG	UDP socket is not created	ERROR
Update dot11 STA database	DEBUG	UDP send failed	ERROR
Add PMKSA to the list	DEBUG	IAPP: socket (SOCK_STREAM) failed.	ERROR
eapolRecvAuthKeyMsg: received key message	DEBUG	IAPP: TCP connect failed to %s.	ERROR
node not found	DEBUG	cmd %d not supported.sender=%d umiloctl(UMI_COMP_KDOT11,%d,%d) failed	ERROR
eapolRecvKeyMsg: replay counter not incremented	DEBUG	IAPP-CACHE-NOTIFY-REQUEST send to	ERROR
eapolRecvKeyMsg: replay counter is not same	DEBUG	./src/dot11/iapp/iappLib.c:1314: ADP_ERROR (	ERROR
processing pairwise key message 2	DEBUG	BSSID value passed is NULL	ERROR
RSN IE matching: OK	DEBUG	reserved requestId is passed	ERROR
processing pairwise key message 4	DEBUG	interface name is NULL	ERROR
processing group key message 2	DEBUG	IP address value passed is NULL	ERROR
processing keyrequest message from client	DEBUG	opening receive UDP socket failed enabling broadcast for UDP socket failed	ERROR
WPA version %2x %2x not supported	DEBUG	opening receive TCP socket for new AP failed	ERROR
(%s) group cipher %2x doesn't match	DEBUG	./src/dot11/iapp/iappLib.c:1784: ADP_ERROR(	ERROR
(%s) Pairwise cipher %s not supported	DEBUG	ADP_ERROR(	ERROR
(%s) authentication method %d not supported	DEBUG	./src/dot11/iapp/iappLib.c:1794: ADP_ERROR(	ERROR
%s:Auth method=%s pairwise cipher=%s IE size=%d	DEBUG	./src/dot11/iapp/iappLib.c:1803: ADP_ERROR(	ERROR
WPA version %2x %2x not supported	DEBUG	failed created dot11 dLock.	ERROR
Unable to obtain IE of type %d	DEBUG	failed initialize profile library.	ERROR
PTK state changed from %s to %s	DEBUG	failed to create cipher contexts.	ERROR
using PMKSA from cache	DEBUG	unable to register to UMI	ERROR
PTK GK state changed from %s to %s	DEBUG	could not create MIB tree	ERROR
GK state changed from %s to %s	DEBUG	unable to register to PNAC	ERROR
Sending PTK Msg1	DEBUG	Max registration attempts by DOT11 to PNAC exceeded	ERROR
Sending PTK Msg3	DEBUG	Creation of EAP WPS Profile Failed	ERROR
Sending GTK Msg1	DEBUG	umiloctl(UMI_COMP_IAPP,%d) failed	ERROR

sending EAPOL pdu to PNAC...	DEBUG	DOT11_RX_EAPOL_KEYMSG: unknown ifname %s	ERROR
creating pnaac authenticator with values %d %d - %s	DEBUG	cmd %d not supported.sender=%d	ERROR
Profile %s does not exist	DEBUG	interface name passed is NULL	ERROR
IAPP initialized.	DEBUG	BSSID passed is NULL	ERROR
Encrypting context key=%s for	DEBUG	interface name passed is NULL	ERROR
could not find access point context for %s	DEBUG	unable to allocate memory for DOT11_CTX	ERROR
join event for existing node %s	DEBUG	unable to install wme mapping on %s	ERROR
failed to send PNAC_FORCE_AUTHORIZED "	DEBUG	unable to get %s mac address	ERROR
failed to send PNAC_AUTHORIZED "	DEBUG	Failed to set %s SSID	ERROR
failed to send PNAC_VAR_KEY_AVAILABLE (TRUE) "	DEBUG	Failed to set SSID broadcast status	ERROR
failed to send PNAC_VAR_KEY_TX_EN (TRUE) "	DEBUG	Failed to set PreAuth mode	ERROR
failed to send PNAC_VAR_KEY_TX_EN (FALSE) "	DEBUG	unable to install key	ERROR
failed to send PNAC_FORCE_AUTHORIZED "	DEBUG	KDOT11_SET_PARAM:IEEE80211_I OC_AUTHMODE failed	ERROR
failed to send PNAC_AUTHORIZED "	DEBUG	KDOT11_SET_PARAM:IEEE80211_I OC_PRIVACY failed	ERROR
mic verification: OK	DEBUG	wpaInit failed	ERROR
pnacIfConfig: Invalid supplicant"	DEBUG	dot11InstallProfile: unable to get interface index	ERROR
Failed to process user request	DEBUG	adpHmacInIt(%s) failed	ERROR
Failed to process user request - %s(%d)	DEBUG	interface %s not found	ERROR
pnacIfConfigUmilOctl: umilOctl failed	DEBUG	AP not found on %s	ERROR
pnacIfConfigUmilOctl: usrPnac returned %d	DEBUG	keyLen > PNAC_KEY_MAX_SIZE	ERROR
pnacIfConfigUmilOctl: usrPnac returned %d	DEBUG	Invalid profile name passed	ERROR
pnacIfConfigUmilOctl: usrPnac returned %d	DEBUG	Creation of WPS EAP Profile failed	ERROR
pnacKernNotifier: invalid PAE configuration "	DEBUG	unsupported command %d	ERROR
From pnaacEapDemoAuthRecv: unsupported response "	DEBUG	device %s not found	ERROR
From pnaacEapDemoAuthRecv: invalid codes received	DEBUG	unsupported command %d	ERROR
From pnaacRadXlateDemoRecv: received unknown "	DEBUG	dot11NodeAlloc failed	ERROR
From pnaacRadXlateDemoRecv: invalid codes received	DEBUG	Getting WPA IE failed for %s	ERROR
Error from pnaacRadXlateDemoRecv: malloc failed	DEBUG	Getting WPS IE failed for %s	ERROR
From pnaacRadXlateRadPktHandle: received a non-supported"	DEBUG	Failed initialize authenticator for node %s	ERROR
Only md5 authentication scheme currently supported. "	DEBUG	Failed to get the system up time while adding node %s	ERROR
Message from authenticator:	DEBUG	error creating PNAC port for node %s	ERROR
from pnaacPDUxmit: bufsize = %d, pktType = %d,"	DEBUG	dot11NodeAlloc failed	ERROR
pnacPDUxmit: sending eap packet. code = %d, "	DEBUG	Invalid arguments.	ERROR

pnacRecvRtn: no corresponding pna port pae found	DEBUG	umiloctl(UMI_COMP_IAPP,%d) failed	ERROR
sending unicast key	DEBUG	Invalid IE.	ERROR
sending broadcast key	DEBUG	umiloctl(UMI_COMP_KDOT11_VAP, %d ) failed	ERROR
from pnaAuthPAEDisconnected: calling pnacTxCannedFail	DEBUG	umiloctl(UMI_COMP_KDOT11,%d ,%d) failed	ERROR
from pnaAuthPAEForceUnauth: calling pnacTxCannedFail	DEBUG	KDOT11_SET_PARAM:IEEE80211_I OC_WME_CWMIN failed	ERROR
state changed from %s to %s	DEBUG	KDOT11_SET_PARAM:IEEE80211_I OC_WME_CWMAX failed	ERROR
PNAC user comp id not set. dropping event %d	DEBUG	KDOT11_SET_PARAM:IEEE80211_I OC_WME_AIFS failed	ERROR
sending event %d to %d	DEBUG	KDOT11_SET_PARAM:80211_IOC_ WME_TXOPLIMIT failed	ERROR
requesting keys informantion from %d	DEBUG	KDOT11_SET_PARAM:IEEE80211_I OC_WME_ACM failed	ERROR
pnacUmiPortPaeParamSet: error in getting port pae	DEBUG	KDOT11_SET_PARAM:IEEE80211_I OC_WME failed	ERROR
pnacUmiPortPaeParamSet: invalid param - %d	DEBUG	invalid group cipher %d	ERROR
pnacRecvASInfoMessage: Skey of length %d set	DEBUG	KDOT11_SET_PARAM:IEEE80211_I OC_MCASTCIPHER failed	ERROR
pnacRecvASInfoMessage: reAuthPeriod set to: %d	DEBUG	KDOT11_SET_PARAM:IEEE80211_I OC_MCASTKEYLEN failed	ERROR
pnacRecvASInfoMessage: suppTimeout set to: %d	DEBUG	KDOT11_SET_PARAM:IEEE80211_I OC_UCASTCIPHERS failed	ERROR
PORT SUCCESSFULLY DESTROYED	DEBUG	KDOT11_SET_PARAM:IEEE80211_I OC_KEYMGALGS failed	ERROR
creating physical port for %s	DEBUG	KDOT11_SET_PARAM:IEEE80211_I OC_WPA failed	ERROR
pnacAuthInit: using default pnacAuthParams	DEBUG	unknow cipher type = %d	ERROR
pnacSuppInit: using default pnacSuppParams	DEBUG	umiloctl(UMI_COMP_IAPP,%d) failed	ERROR
Error from pnacCombinedStMachTriggerFunc: "	DEBUG	invalid media value=%d	ERROR
Error from pnacCombinedStMachTriggerFunc: "	DEBUG	invalid mediaOpt value=%d	ERROR
Error from pnacCombinedStMachTriggerFunc: "	DEBUG	invalid mode value=%d	ERROR
Error from pnacCombinedStMachTriggerFunc: "	DEBUG	dot11PnaclfCreate failed	ERROR
Error from pnacCombinedStMachTriggerFunc: "	DEBUG	wpaPRF failed	ERROR
Error from pnacCombinedStMachTriggerFunc: "	DEBUG	Error generating global keycounter	ERROR
Error from pnacCombinedStMachTriggerFunc: "	DEBUG	wpaCalcMic: unsupported key descriptor version	ERROR
Error from pnacCombinedStMachTriggerFunc: "	DEBUG	integrity failed. need to stop all stations "	ERROR
Error from pnacCombinedStMachTriggerFunc: "	DEBUG	couldn't find AP context for %s interface	ERROR
received a pdu on %s	DEBUG	dot11Malloc failed	ERROR
pnacRecvMapi: protoType: %04x pPhyPort->authToASSendRtn:%p	DEBUG	dot11Malloc failed	ERROR
port not found	DEBUG	eapolRecvKeyMsg: unknown descType =%d	ERROR

from pncacRecvMapi: pkt body len = %d, pktType = %d	DEBUG	eapolRecvKeyMsg: invalid descriptor version	ERROR
from pncacPDUPProcess: received PNCAC_EAP_PACKET	DEBUG	eapolRecvKeyMsg: incorrect descriptor version	ERROR
from pncacPDUPProcess: currentId = %d	DEBUG	eapolRecvKeyMsg: Ack must not be set	ERROR
from pncacPDUPProcess: code = %d, identifier = %d, "	DEBUG	eapolRecvKeyMsg: MIC bit must be set	ERROR
from pncacPDUPProcess: setting rxResp true	DEBUG	wpaAuthRecvPTKMsg2: unexpected packet received	ERROR
from pncacPDUPProcess: code = %d, identifier = %d, "	DEBUG	wpaAuthRecvPTKMsg2: mic check failed	ERROR
from pncacPDUPProcess: received "	DEBUG	wpaAuthRecvPTKMsg2: rsnie mismatch	ERROR
from pncacPDUPProcess: received "	DEBUG	wpaAuthRecvPTKMsg4: unexpected packet received	ERROR
from pncacPDUPProcess: received PNCAC_EAPOL_KEY_PACKET	DEBUG	wpaAuthRecvPTKMsg4: keyDataLength not zero	ERROR
doing pncacTxCannedFail	DEBUG	wpaAuthRecvPTKMsg4: mic check failed	ERROR
doing pncacTxCannedSuccess	DEBUG	wpaAuthRecvGTKMsg2: unexpected packet received	ERROR
doing pncacTxReqId	DEBUG	secureBit not set in GTK Msg2	ERROR
doing pncacTxReq	DEBUG	wpaAuthRecvGTKMsg2: keyDataLength not zero	ERROR
doing pncacTxStart	DEBUG	wpaAuthRecvGTKMsg2: mic check failed	ERROR
doing pncacTxLogoff	DEBUG	wpaAuthRecvKeyReq: unexpected packet received	ERROR
doing pncacTxRspld: 1st cond	DEBUG	wpaAuthRecvKeyReq: keyDataLength not zero	ERROR
doing pncacTxRspld: entering 2nd cond	DEBUG	wpaAuthRecvKeyReq: mic check failed	ERROR
from pncacTxRspld: code = %d, identifier = %d, length = %d, "	DEBUG	invalid OUI %x %x %x	ERROR
doing pncacTxRspld: 2nd cond	DEBUG	(%s) invalid OUI %x %x %x	ERROR
doing pncacTxRspAuth: 1st cond	DEBUG	[%s:%d] Cipher in WPA IE : %x	ERROR
doing pncacTxRspAuth: 2nd cond	DEBUG	(%s) invalid OUI %x %x %x	ERROR
message for unknown port PAE	DEBUG	short WPA IE (length = %d) received	ERROR
from pncacACToSuppRecvRtn: calling pncacEapPktRecord	DEBUG	PTK state machine in unknown state.	ERROR
from pncacEapPktRecord: code = %d, identifier = %d, "	DEBUG	dot11InstallKeys failed	ERROR
from pncacEapPktRecord: received success pkt	DEBUG	group state machine entered into WPA_AUTH_GTK_INIT	ERROR
from pncacEapPktRecord: received failure pkt	DEBUG	dot11Malloc failed	ERROR
from pncacEapPktRecord: received request pkt	DEBUG	dot11Malloc failed	ERROR
unknown EAP-code %d	DEBUG	dot11Malloc failed	ERROR
Authenticator[%d]:	DEBUG	aesWrap failed	ERROR
Auth PAE state = %s	DEBUG	unknown key descriptor version %d	ERROR
Auth Reauth state = %s	DEBUG	dot11Malloc failed	ERROR
Back auth state = %s	DEBUG	could not initialize AES128ECB	ERROR
Supplicant[%d]:	DEBUG	could not initialize AES-128-ECB	ERROR
Supp Pae state = %s	DEBUG	MD5 initialization failed	ERROR

from pncBackAuthFail: calling pncTxCannedFail	DEBUG	RC4 framework initialization failed	ERROR
%s returned ERROR	DEBUG	PNAC framework initialization failed	ERROR
pncUmiloctlHandler: cmd: %s(%d)	DEBUG	ERROR: option value not specified	ERROR
%s not configured for 802.1x	DEBUG	ERROR: -u can be used only with -s	ERROR
could not process PDU received from the wire	DEBUG	ERROR: user-name not specified	ERROR
pncPDUForward: failed to forward the received PDU	DEBUG	failed to enable debug	ERROR
Creating PHY port with AUTH backend : %s SendRtn: %p RecvRtn:%p	DEBUG	[%s]: failed to convert string to MAC "	ERROR
pncUmiAuthConfig: %s not configured for 802.1x	DEBUG	failed to initialize UMI	ERROR
pncSuppRegisterUserInfo: not a valid AC	DEBUG	pncPhyPortParamSet:invalid arguments	ERROR
pncIfConfig: autoAuth Enabled	DEBUG	pncPhyPortParamSet:Failed to create socket	ERROR
pncSendRtn: no pnc port pae found for "	DEBUG	Error from pncPhyPortParamSet:%s-device invalid	ERROR
sending portStatus: %s[%d] to dot11	DEBUG	Error from pncPhyPortParamSet:%s-Getting MAC address "	ERROR
pncRecvASInfoMessage: Rkey of length %d set	DEBUG	pncPhyPortParamSet:Failed to add 802.1X multicast "	ERROR
ASSendRtn: %p ASToAuthRecv: %p	DEBUG	pncInterfaceUp: failed to create a raw socket	ERROR
adpRand failed:unable to generate random unicast key	WARN	pncInterfaceUp: failed to get interface flags	ERROR
using group key as unicast key	WARN	failed to allocate buffer	ERROR
Integrity check failed more than once in last 60 secs.	WARN	UMI initialization failed	ERROR
MIC failed twice in last 60 secs, taking countermeasures	WARN	UMI initialization failed	ERROR
Failed to set dot11 port status	WARN	Error from pncEapDemoAuthLibInit: malloc failed	ERROR
PTK state machine in NO_STATE.	WARN	Error from pncEapDemoAuthRecv: received null EAP pkt	ERROR
PTK state machine in NO_STATE!!	WARN	Error from pncEapDemoAuthRecv: send "	ERROR
PMKSA recount not 1	WARN	Error from pncRadXlateASAdd: cannot open socket	ERROR
IV verification failedknown subtype>	WARN	Error from pncRadXlateDemoRecv: received null EAP pkt	ERROR
pncIfConfig: overwriting previous interface "	WARN	From pncRadXlateDemoRecv: send "	ERROR
pncIfConfig: overwriting previous "	WARN	Error from pncRadXlateDemoRecv: radius "	ERROR
pncIfConfig: overwriting previous username"	WARN	Error from pncRadXlateDemoRecv: radius "	ERROR
pncIfConfig: overwriting previous password"	WARN	Error from pncRadXlateRadIdRespSend: send to failed	ERROR
%s: Failed to set port status	WARN	Error from pncRadXlateRadNonIdRespSend: send to failed	ERROR
%s: Failed to notify event to dot11	WARN	Error from pncRadXlateRadRecvProc: recvfrom failed	ERROR
pncLibDeinit: Failed to destroy the	WARN	From	ERROR

phyPort:%s		pnacRadXlateRadPktIntegrityChk: no corresponding "	
pnacPortPaeDeconfig:kpnacPortPaeDec onfig failed	WARN	Error from pnacRadXlateRadPktIntegrityChk: no message "	ERROR
pnacPortPaeDeconfig:kpnacPortPaeDec onfig failed	WARN	Error from pnacRadXlateRadPktIntegrityChk: "	ERROR
pnacBackAuthSuccess: failed to notify the destination "	WARN	From pnacRadXlateRadChalPktHandle: no encapsulated eap "	ERROR
could not initialize MGMT framework	ERROR	Error from pnacRadXlateRadChalPktHandle: malloc for eap "	ERROR
umilnit failed	ERROR	Error from pnacEapDemoSuppUserInfoRegister: invalid "	ERROR
iapplnit failed	ERROR	Error from pnacEapDemoSuppRecv: received null EAP pkt	ERROR
could not initialize IAPP MGMT.	ERROR	Error from pnacEapDemoSuppRecv: send ptr to pnac supplicant"	ERROR
dot11Malloc failed	ERROR	From pnacEapDemoSuppRecv: user info not entered yet	ERROR
buffer length not specified	ERROR	Error from pnacEapDemoSuppRecv: couldn't"	ERROR
Invalid length(%d) specified	ERROR	MDString: adpDigestInit for md5 failed	ERROR
Failed to get information about authorized AP list.	ERROR	pnacUmilnit: UMI initialization failed	ERROR
Recd IE data for non-existent AP %s	ERROR	could not start PNAC task	ERROR
Recd IE data for wrong AP %s	ERROR	invalid aruments	ERROR
Received Invalid IE data from WSC	ERROR	pnacIfNameToIndexfailed	ERROR
Recd IE data for non-existent AP %s	ERROR	pnacPhyPortParamSet: device invalid %s%d	ERROR
Recd WSC Start command without interface name	ERROR	pnacPhyPortParamSet: EIOCGADDR ioctl failed	ERROR
Recd WSC start for non-existent AP %s	ERROR	pnacPhyPortParamSet: multicast addr add ioctl failed	ERROR
Recd WSC start for wrong AP %s	ERROR	pnacPhyPortParamUnset: multicast addr del ioctl failed	ERROR
Unable to send WSC_WLAN_CMD_PORT to WSC	ERROR	pnacPDUxmit: Invalid arguments	ERROR
Failed to get the ap context for %s	ERROR	pnacPDUxmit: failed to get M_BLK_ID	ERROR
WPS can only be applied to WPAWPA2 security profiles	ERROR	from pnaclsInterfaceUp: device %s%d invalid	ERROR
wpsEnable: running wscmd failed	ERROR	pnacRecvRtn: dropping received packet as port is"	ERROR
Failed to get the ap context for %s	ERROR	pnacSendRtn: Invalid arguments	ERROR
WPS conf. under non WPAWPA2 security setting	ERROR	pnacSendRtn: no physical port corresponding to"	ERROR
Failed to reset the Beacon Frame IE in the driver	ERROR	pnacSendRtn: dropping packet as port"	ERROR
Failed to reset the Beacon Frame IE in the driver	ERROR	pnacAuthBuildRC4KeyDesc: adpEncryptInit(RC4) failed	ERROR
WPS method cannot be NULL	ERROR	pnacAuthBuildRC4KeyDesc: adpCipherContextCtrl"	ERROR
PIN value length should be a multiple of 4 !!	ERROR	pnacDot11UserSet: incorrect buffer length	ERROR
Failed to initiate PIN based association, PIN = %s	ERROR	PNAC user component id not set.	ERROR



Failed to initiate PBC based enrolle association	ERROR	pnacKeyInfoGet:failed to allocate buffer	ERROR
Invalid association mode. (Allowed modes : PIN/PBC)	ERROR	PNAC user comp id not set. dropping EAPOL key pkt	ERROR
wpsEnable: running wscmd failed	ERROR	pnacUmiPortPaeParamSet: invalid buffer received	ERROR
Failed to send QUIT command to WSC from DOT11	ERROR	Error from pnaRecvASInfoMessage: "	ERROR
Failed to clear off the WPS process	ERROR	pnacRecvASInfoMessage: "	ERROR
missing profile name	ERROR	pnacRecvASInfoMessage: Bad info length	ERROR
A profile exists with the same name	ERROR	Error from pnaLiblNit: malloc failed	ERROR
Error in allocating memory for profile	ERROR	could not create phy ports lock	ERROR
missing profile name	ERROR	could not create nodes ports lock	ERROR
missing profile name	ERROR	port exists for iface - %s	ERROR
Profile name and interface name must be specified	ERROR	pnacPhyPortCreate failed	ERROR
Profile %s does not exist	ERROR	kpnacPhyPortCreate failed	ERROR
Could not set profile %s on the interface %s	ERROR	invalid argument	ERROR
missing profile name	ERROR	pnacAuthConfig: maxAuth limit reached	ERROR
Profile %s does not exist	ERROR	pnacAuthConfig: malloc failed	ERROR
Profile %s does not exist	ERROR	Error from pnaAuthConfig: pAsArg cannot be NULL	ERROR
SSID should not be longer than %d	ERROR	Error from pnaAuthConfig: receive routine hook "	ERROR
Profile %s does not exist	ERROR	pnacAuthConfig: pnaAuthInit failed	ERROR
Profile %s does not exist	ERROR	kpnacPortPaeConfig failed	ERROR
Profile %s does not exist	ERROR	Invalid arguments	ERROR
Profile %s does not exist	ERROR	Error from pnaSuppConfig: malloc failed	ERROR
Profile %s does not exist	ERROR	Error from pnaSuppConfig: receive routine hook "	ERROR
Profile %s does not exist	ERROR	Error from pnaSuppConfig: pnaSupplnit failed	ERROR
SSID not set. SSID is needed to generate password hash	ERROR	kpnacPortPaeConfig failed	ERROR
Password string too big	ERROR	pnacAuthDeconfig failed: pPortPae NULL	ERROR
dot11Malloc failed	ERROR	Error from pnaPhyPortDestroy: port not configured	ERROR
Profile %s does not exist	ERROR	pnacPhyPortDestroy: Failed to deconfigure port	ERROR
Hex string should only have %d hex chars	ERROR	pnacPhyPortParamUnset FAILED	ERROR
dot11Malloc failed	ERROR	Error from pnaPhyPortCreate: malloc failed	ERROR
Profile %s does not exist	ERROR	Error from pnaPhyPortCreate: pnaPhyPortParam Set"	ERROR
invalid key index %d. key index should be 0-3.	ERROR	error from pnaPhyPortCreate: malloc failed	ERROR
wepKey length incorrect	ERROR	Error from pnaAuthInit: pnaPortTimersInit failed	ERROR
Profile %s does not exist	ERROR	Error from pnaAuthInit: pnaAuthPAEInit failed	ERROR

Invalid Cipher type %d	ERROR	Error from pncAuthInit: pncAuthKeyTxInit failed	ERROR
Profile supports WEP stas,Group cipher must be WEP	ERROR	Error from pncAuthInit: pncReauthTimerInit failed	ERROR
Profile %s does not exist	ERROR	Error from pncAuthInit: pncBackAuthInit failed	ERROR
Profile %s does not exist	ERROR	Error from pncAuthInit: pncCtrlDirInit failed	ERROR
Profile %s does not exist	ERROR	Error from pncAuthInit: pncKeyRecvInit failed	ERROR
invalid pairwise cipher type %d	ERROR	Error from pncSupplnit: malloc failed	ERROR
Cipher %s is already in the list.	ERROR	Error from pncSupplnit: pncPortTimersInit failed	ERROR
Profile %s does not exist	ERROR	Error from pncSupplnit: pncKeyRecvInit failed	ERROR
Invalid Cipher type %d	ERROR	Error from pncSupplnit: pncSuppKeyTxInit failed	ERROR
Cipher %s not found in the list.	ERROR	Error from pncSupplnit: pncSuppPAEInit failed	ERROR
Profile %s does not exist	ERROR	Error from pncRecvRtn: invalid arguments	ERROR
Profile %s does not exist	ERROR	Error from pncRecvMapi: unsupported PDU received	ERROR
Auth method %s is already in the list	ERROR	suppToACSendRtn returned not OK!	ERROR
Profile %s does not exist	ERROR	Error from pncBasicPktCreate: malloc failed	ERROR
Auth method %s not found in the list.	ERROR	Error from pncEAPPktCreate: basic pkt create failed	ERROR
Profile %s does not exist	ERROR	Error from pncTxCannedFail: eap pkt create failed	ERROR
Profile %s does not exist	ERROR	Error from pncTxCannedSuccess: eap pkt create failed	ERROR
Profile %s does not exist	ERROR	Error from pncTxReqId: eap pkt create failed	ERROR
invalid type value %d. supported values are 1,2,3,4	ERROR	Error from pncTxReq: eap pkt create failed	ERROR
Profile %s does not exist	ERROR	Error from pncSendRespToServer: malloc failed	ERROR
invalid type value %d. supported values are 1,2,3,4	ERROR	Error from pncSendRespToServer: no AS configured	ERROR
Profile %s does not exist	ERROR	Error from pncTxStart: basic pkt create failed	ERROR
invalid type value %d. supported values are 1,2,3,4	ERROR	Error from pncTxStart: basic pkt create failed	ERROR
Profile %s does not exist	ERROR	Error from pncTxRspld: eap pkt create failed	ERROR
invalid type value %d. supported values are 1,2,3,4	ERROR	Error from pncTxRspAuth: eap pkt create failed	ERROR
Profile %s does not exist	ERROR	Error from pncEapPktRecord: EAP packet too"	ERROR
invalid type value %d. supported values are 1,2,3,4	ERROR	Error from pncEapPktRecord: "	ERROR
Profile %s does not exist	ERROR	from pncBackAuthTimeout: calling pncTxCannedFail	ERROR
ERROR: incomplete DB update information.	ERROR	hmac_md5: adpHmacContextCreate failed	ERROR
old values result does not contain 2 rows	ERROR	hmac_md5: adpHmacInit failed	ERROR
sqlite3QueryResGet failed	ERROR	pncUmIoctlHandler: invalid cmd: %d	ERROR

Error in executing DB update handler	ERROR	pnacEapRadAuthSend: Invalid arguments	ERROR
sqlite3QueryResGet failed	ERROR	pnacEapRadAuthSend: failed to allocate inbuffer	ERROR
ERROR: incomplete DB update information.	ERROR	pnacXmit: umiloctl failed[%d]	ERROR
old values result does not contain 2 rows	ERROR	pnacPDUForward: Invalid input	ERROR
sqlite3QueryResGet failed	ERROR	pnacPDUForward: error in getting port pae information	ERROR
Error in executing DB update handler	ERROR	pnacPDUForward: error allocating memory	ERROR
sqlite3QueryResGet failed.Query:%s	ERROR	pnacUmilfMacAddrChange: %s not configured for 802.1x	ERROR
sqlite3QueryResGet failed.Query:%s	ERROR	pnacUmilfMacAddrChange: could not process PDU received"	ERROR
sqlite3QueryResGet failed.Query:%s	ERROR	pnacUmiphyPortConfig: Invalid config data	ERROR
sqlite3QueryResGet failed.Query:%s	ERROR	pnacUmiphyPortConfig: Invalid backend name specified	ERROR
startStopVap failed to stop %s	ERROR	pnacUmiphyPortConfig: could not create PNAC physical"	ERROR
Invalid SQLITE operation code - %d	ERROR	pnacUmiauthConfig: Invalid config data	ERROR
./src/dot11/mgmt/dot11Mgmt.c:1177: ADP_ERROR (	ERROR	pnacUmiauthConfig: Invalid backend name specified	ERROR
only delete event expected on dot11RogueAP.	ERROR	unable to create new EAP context. unable to apply %s profile on the EAP context.	ERROR
sqlite3QueryResGet failed	ERROR	pnacUmiauthConfig: could not configure PNAC PAE "	ERROR
unhandled database operation %d	ERROR	pnacUmisuppConfig: Invalid config data	ERROR
sqlite3QueryResGet failed	ERROR	pnacUmisuppConfig: Invalid backend name specified	ERROR
failed to configure WPS on %s	ERROR	pnacUmisuppConfig: %s not configured for 802.1x	ERROR
sqlite3QueryResGet failed	ERROR	pnacUmisuppConfig: could not PNAC port Access"	ERROR
sqlite3QueryResGet failed	ERROR	pnacUmisuppConfig: Failed to register user information	ERROR
sqlite3QueryResGet failed	ERROR	pnacPortByMacDeconfig: port not found	ERROR
sqlite3QueryResGet failed	ERROR	pnacPortByMacDeconfig: port not found	ERROR
no VAP rows returned. expected one multiple VAP rows returned. expected one	ERROR	pnacUmilfDown: Invalid config data	ERROR
sqlite3QueryResGet failed	ERROR	pnacUmilfDown: Invalid config data	ERROR
invalid query result. ncols=%d n rows=%d	ERROR	Error from pnacPortDeconfig: port not configured	ERROR
%s:VAP(%s) create failed	ERROR	pnacUmilfDown: could not de-configure port	ERROR
sqlite3QueryResGet failed	ERROR	pnacUmiphyPortDestroy: Invalid config data	ERROR
invalid query result. ncols=%d n rows=%d	ERROR	pnacUmiphyPortDestroy: Invalid config data	ERROR
	ERROR	pnacUmiphyPortDestroy: Failed to destroy the port	ERROR

	Invalid config data	ERROR
--	---------------------	-------

**Facility: Kernel**

Log Message	Severity	Log Message	Severity
DNAT: multiple ranges no longer supported	DEBUG	%s: %s%: %d -> %s: %d %s,	DEBUG
DNAT: Target size %u wrong for %u ranges,	DEBUG	%s: %s%: %d %s,	DEBUG
DNAT: wrong table %s, tablename	DEBUG	%s: Failed to add WDS MAC: %s, dev->name,	DEBUG
DNAT: hook mask 0x%x bad, hook_mask	DEBUG	%s: Device already has WDS mac address attached,	DEBUG
%s%: resetting MPPC/MPPE compressor,	DEBUG	%s: Added WDS MAC: %s, dev->name,	DEBUG
%s%: wrong offset value: %d,	DEBUG	%s: WDS MAC address %s is not known by this interface,	DEBUG
%s%: wrong length of match value: %d,	DEBUG	[madwifi] %s(): Not enough space., __FUNCTION__	DEBUG
%s%: too big offset value: %d,	DEBUG	Returning to chan %d, ieeeChan	DEBUG
%s%: cannot decode offset value,	DEBUG	WEP	DEBUG
%s%: wrong length code: 0x%X,	DEBUG	AES	DEBUG
%s%: short packet (len=%d), __FUNCTION__,	DEBUG	AES_CCM	DEBUG
%s%: bad sequence number: %d, expected: %d,	DEBUG	CKIP	DEBUG
%s%: bad sequence number: %d, expected: %d,	DEBUG	TKIP	DEBUG
PPPIOCDETACH file->f_count=%d,	DEBUG	%s: cannot map channel to mode; freq %u flags 0x%x,	DEBUG
PPP: outbound frame not passed	DEBUG	%s: %s, vap->iv_dev->name, buf	DEBUG
PPP: VJ decompression error	DEBUG	%s: [%s] %s, vap->iv_dev->name,	DEBUG
PPP: inbound frame not passed	DEBUG	%s: [%s] %s, vap->iv_dev->name, ether_sprintf(mac), buf	DEBUG
PPP: reconstructed packet	DEBUG	[%s: %s] discard %s frame, %s, vap->iv_dev->name,	DEBUG
PPP: no memory for	DEBUG	[%s: %s] discard frame, %s, vap->iv_dev->name,	DEBUG
missed pkts %u..%u,	DEBUG	[%s: %s] discard %s information element, %s,	DEBUG
%s%: resetting MPPC/MPPE compressor,	DEBUG	[%s: %s] discard information element, %s,	DEBUG
%s%: wrong offset value: %d,	DEBUG	[%s: %s] discard %s frame, %s, vap->iv_dev->name,	DEBUG
%s%: wrong length of match value: %d,	DEBUG	[%s: %s] discard frame, %s, vap->iv_dev->name,	DEBUG
%s%: too big offset value: %d,	DEBUG	ifmedia_add: null ifm	DEBUG
%s%: cannot decode offset value,	DEBUG	Adding entry for	DEBUG
%s%: wrong length code: 0x%X,	DEBUG	ifmedia_set: no match for 0x%x/0x%x,	DEBUG
%s%: short packet (len=%d), __FUNCTION__,	DEBUG	ifmedia_set: target	DEBUG
%s%: bad sequence number: %d, expected: %d,	DEBUG	ifmedia_set: setting to	DEBUG

%s%d: bad sequence number: %d, expected: %d,	DEBUG	ifmedia_ioctl: no media found for 0x%x,	DEBUG
PPPIOCDETACH file->f_count=%d,	DEBUG	ifmedia_ioctl: switching %s to , dev->name	DEBUG
PPP: outbound frame not passed	DEBUG	ifmedia_match: multiple match for	DEBUG
PPP: VJ decompression error	DEBUG	<unknown type>	DEBUG
PPP: inbound frame not passed	DEBUG	desc->ifmt_string	DEBUG
PPP: reconstructed packet	DEBUG	mode %s, desc->ifmt_string	DEBUG
PPP: no memory for	DEBUG	<unknown subtype>	DEBUG
missed pkts %u..%u,	DEBUG	%s, desc->ifmt_string	DEBUG
%s: INC_USE_COUNT, now %d, __FUNCTION__, mod_use_count\	DEBUG	%s%s, seen_option++ ? , : ,	DEBUG
%s: DEC_USE_COUNT, now %d, __FUNCTION__, mod_use_count\	DEBUG	%s%s, seen_option++ ? , : ,	DEBUG
PPPOL2TP %s: _fmt,	DEBUG	%s, seen_option ? > :	DEBUG
PPPOL2TP: --> %s, __FUNCTION__)	DEBUG	%s: %s, dev->name, buf	DEBUG
PPPOL2TP: <-- %s, __FUNCTION__)	DEBUG	%s: no memory for sysctl table!, __func__	DEBUG
%s: recv. , tunnel->name	DEBUG	%s: no memory for VAP name!, __func__	DEBUG
%s: xmit, session->name	DEBUG	%s: failed to register sysctls!, vap->iv_dev->name	DEBUG
%s: xmit, session->name	DEBUG	%s: no memory for new proc entry (%s)!, __func__,	DEBUG
%s: module use_count is %d, __FUNCTION__, mod_use_count	DEBUG	%s: 0x%p len %u, tag, p, len	DEBUG
PPPOL2TP %s: _fmt,	DEBUG	%03d:, i	DEBUG
PPPOL2TP: --> %s, __FUNCTION__)	DEBUG	%02x, ((u_int8_t*)p)[i]	DEBUG
PPPOL2TP: <-- %s, __FUNCTION__)	DEBUG	first difference at byte %u, i	DEBUG
%s: recv. , tunnel->name	DEBUG	%s: , t->name	DEBUG
%s: xmit, session->name	DEBUG	FAIL: ieee80211_crypto_newkeyfailed	DEBUG
%s: xmit, session->name	DEBUG	FAIL: ieee80211_crypto_setkeyfailed	DEBUG
PPPOL2TP %s: _fmt,	DEBUG	FAIL: unable to allocate skbuff	DEBUG
PPPOL2TP: --> %s, __FUNCTION__)	DEBUG	FAIL: wep decap failed	DEBUG
PPPOL2TP: <-- %s, __FUNCTION__)	DEBUG	FAIL: decap botch; length mismatch	DEBUG
%s: recv. , tunnel->name	DEBUG	FAIL: decap botch; data does not compare	DEBUG
%s: xmit, session->name	DEBUG	FAIL: wep encap failed	DEBUG
%s: xmit, session->name	DEBUG	FAIL: encap data length mismatch	DEBUG
IRQ 31 is triggered	DEBUG	FAIL: encrypt data does not compare	DEBUG
[%s:%d], __func__, __LINE__\	DEBUG	PASS	DEBUG
\t[R%s %#0x %#0x 0x%08x%08x], (status == ERROR ? # : ), page, addr, (uint32_t)(*pValue >> 32), (uint32_t)(*pValue & 0xffffffff)	DEBUG	%u of %u 802.11i WEP test vectors passed, pass, total	DEBUG
\t[W%s %#0x %#0x 0x%08x%08x], (status == ERROR ? # : ), page, addr, (uint32_t)(value >> 32), (uint32_t)(value & 0xffffffff)	DEBUG	%s: 0x%p len %u, tag, p, len	DEBUG
%s: mac_addr %02X:%02X:%02X:%02X:%02X:%02X, dev->name, addr[0], addr[1], addr[2], addr[3], addr[4], addr[5]	DEBUG	%03d:, i	DEBUG

%s: mac_del %02X:%02X:%02X:%02X:%02X:%02X, dev->name, addr[0], addr[1], addr[2], addr[3], addr[4], addr[5]	DEBUG	%02x, ((u_int8_t*)p)[i]	DEBUG
%s: mac_kick %02X:%02X:%02X:%02X:%02X:%02X, dev->name, addr[0], addr[1], addr[2], addr[3], addr[4], addr[5]	DEBUG	first difference at byte %u, i	DEBUG
%s: mac_undefined %02X:%02X:%02X:%02X:%02X:%02X, dev->name, addr[0], addr[1], addr[2], addr[3], addr[4], addr[5]	DEBUG	%s:, t->name	DEBUG
%s: addr_add %02X:%02X:%02X:%02X:%02X:%02X, dev->name, addr[0], addr[1], addr[2], addr[3], addr[4], addr[5]	DEBUG	FAIL: ieee80211_crypto_newkeyfailed	DEBUG
%s: addr_del %02X:%02X:%02X:%02X:%02X:%02X, dev->name, addr[0], addr[1], addr[2], addr[3], addr[4], addr[5]	DEBUG	FAIL: ieee80211_crypto_setkeyfailed	DEBUG
%s: mac_undefined %02X:%02X:%02X:%02X:%02X:%02X, dev->name, addr[0], addr[1], addr[2], addr[3], addr[4], addr[5]	DEBUG	FAIL: unable to allocate skbuff	DEBUG
%s: set_float %d;%d,	DEBUG	FAIL: ccmp encap failed	DEBUG
IRQ 32 is triggered	DEBUG	FAIL: encap data length mismatch	DEBUG
ip_finish_output2: No header cache and no neighbour!	DEBUG	FAIL: encrypt data does not compare	DEBUG
a guy asks for address mask. Who is it?	DEBUG	FAIL: ccmp decap failed	DEBUG
icmp v4 hw csum failure)	DEBUG	FAIL: decap botch; length mismatch	DEBUG
expire>> %u %d %d %d, expire,	DEBUG	FAIL: decap botch; data does not compare	DEBUG
expire++ %u %d %d %d, expire,	DEBUG	PASS	DEBUG
rt_cache @%02x: %u.%u.%u.%u, hash,	DEBUG	%u of %u 802.11i AES-CCMP test vectors passed, pass, total	DEBUG
rt_bind_peer(0) @%p, NET_CALLER(iph)	DEBUG	%s: 0x%p len %u, tag, p, len	DEBUG
ip_rt_advice: redirect to	DEBUG	%03d:, i	DEBUG
ip_rt_bug: %u.%u.%u.%u -> %u.%u.%u.%u, %s,	DEBUG	%02x, ((u_int8_t*)p)[i]	DEBUG
udp cork app bug 2)	DEBUG	first difference at byte %u, i	DEBUG
udp cork app bug 3)	DEBUG	ieee80211_crypto_newkeyfailed	DEBUG
udp v4 hw csum failure.)	DEBUG	ieee80211_crypto_setkeyfailed	DEBUG
UDP: short packet: From %u.%u.%u.%u:%u %d/%d to %u.%u.%u.%u:%u,	DEBUG	unable to allocate skbuff	DEBUG
UDP: bad checksum. From %d.%d.%d.%d:%d to %d.%d.%d.%d:%d ulen %d,	DEBUG	tkip enmic failed	DEBUG
%s: lookup policy [list] found=%s,	DEBUG	enmic botch; length mismatch	DEBUG
%s: called: [output START], __FUNCTION__	DEBUG	enmic botch	DEBUG
%s: flow dst=%s, __FUNCTION__, XFRMSTRADDR(fl->fl4_dst, family)	DEBUG	tkip encap failed	DEBUG
%s: flow src=%s, __FUNCTION__, XFRMSTRADDR(fl->fl4_src, family)	DEBUG	encrypt phase1 botch	DEBUG

%s: flow dst=%s, __FUNCTION__, XFRMSTRADDR(fl->fl6_dst, family)	DEBUG	encrypt data length mismatch	DEBUG
%s: flow src=%s, __FUNCTION__, XFRMSTRADDR(fl->fl6_src, family)	DEBUG	encrypt data does not compare	DEBUG
a guy asks for address mask. Who is it? icmp v4 hw csum failure)	DEBUG	tkip decap failed	DEBUG
expire>> %u %d %d %d, expire,	DEBUG	decrypt phase1 botch	DEBUG
expire++ %u %d %d %d, expire,	DEBUG	decrypt data does not compare	DEBUG
rt_cache @%02x: %u.%u.%u.%u, hash,	DEBUG	decap botch; length mismatch	DEBUG
rt_bind_peer(0) @%p, NET_CALLER(iph)	DEBUG	decap botch; data does not compare	DEBUG
ip_rt_advice: redirect to	DEBUG	tkip demic failed	DEBUG
ip_rt_bug: %u.%u.%u.%u->%u.%u.%u.%u, %s,	DEBUG	802.11i TKIP test vectors passed	DEBUG
UDP: shortpacket: From %u.%u.%u.%u: %u %d/%d to %u.%u.%u.%u: %u,	DEBUG	%s, buf	DEBUG
UDP: bad checksum. From %d.%d.%d.%d: %d to %d.%d.%d.%d: %d ulen %d,	DEBUG	Atheros HAL assertion failure: %s: line %u: %s,	DEBUG
a guy asks for address mask. Who is it?	DEBUG	ath_hal: logging to %s %s, ath_hal_logfile,	DEBUG
fib_add_ifaddr: bug: prim == NULL	DEBUG	ath_hal: logging disabled	DEBUG
fib_del_ifaddr: bug: prim == NULL	DEBUG	%s%s, sep, ath_hal_buildopts[j] ath_pci: No devices found, driver not installed.	DEBUG
expire>> %u %d %d %d, expire,	DEBUG	_fmt, __VA_ARGS__	DEBUG
expire++ %u %d %d %d, expire,	DEBUG	%s: Warning, using only %u entries in %u key cache,	DEBUG
rt_cache @%02x: %u.%u.%u.%u, hash,	DEBUG	%s: TX99 support enabled, dev->name %s: grppoll Buf allocation failed	DEBUG
rt_bind_peer(0) @%p,	DEBUG	, __func__	DEBUG
ip_rt_advice: redirect to	DEBUG	%s: %s: unable to start recv logic,	DEBUG
ip_rt_bug: %u.%u.%u.%u->%u.%u.%u.%u, %s,	DEBUG	%s: %s: unable to start recv logic,	DEBUG
%s: lookup policy [list] found=%s,	DEBUG	%s: no skbuff, __func__	DEBUG
%s: called: [output START], __FUNCTION__	DEBUG	%s: hardware error; resetting, dev->name	DEBUG
%s: flow dst=%s, __FUNCTION__, XFRMSTRADDR(fl->fl4_dst, family)	DEBUG	%s: rx FIFO overrun; resetting, dev->name	DEBUG
%s: flow src=%s, __FUNCTION__, XFRMSTRADDR(fl->fl4_src, family)	DEBUG	%s: unable to reset hardware: '%s' (HAL status %u)	DEBUG
%s: flow dst=%s, __FUNCTION__, XFRMSTRADDR(fl->fl6_dst, family)	DEBUG	%s: unable to start recv logic, dev->name	DEBUG
%s: flow src=%s, __FUNCTION__, XFRMSTRADDR(fl->fl6_src, family)	DEBUG	%s: %s: unable to reset hardware: '%s' (HAL status %u),	DEBUG
a guy asks for address mask. Who is it? icmp v4 hw csum failure)	DEBUG	%s: %s: unable to start recv logic,	DEBUG
expire>> %u %d %d %d, expire,	DEBUG	ath_mgts start: discard, no xmit buf	DEBUG
expire++ %u %d %d %d, expire,	DEBUG	%s: [%02u] %-7s , tag, ix, ciphers[hk->kv_type]	DEBUG
rt_cache @%02x: %u.%u.%u.%u, hash,	DEBUG	%02x, hk->kv_val[j]	DEBUG
rt_bind_peer(0) @%p, NET_CALLER(iph)	DEBUG	mac %s, ether_sprintf(mac)	DEBUG
ip_rt_advice: redirect to	DEBUG	%s , sc->sc_splitmic ? mic : rxmic	DEBUG
	DEBUG	%02x, hk->kv_mic[j]	DEBUG

ip_rt_bug: %u.%u.%u.%u -> %u.%u.%u.%u, %s,	DEBUG	txmic	DEBUG
UDP: short packet: From %u.%u.%u.%u: %u %d/%d to %u.%u.%u.%u: %u,	DEBUG	%02x, hk->kv_txmic[i]	DEBUG
UDP: bad checksum. From %d.%d.%d.%d: %d to %d.%d.%d.%d: %d ulen %d,	DEBUG	%s: unable to update h/w beacon queue parameters,	DEBUG
REJECT: ECHOREPLY no longer supported.	DEBUG	%s: stuck beacon; resetting (bmiss count %u),	DEBUG
ipt_rpc: only valid for PRE_ROUTING, FORWARD, POST_ROUTING, LOCAL_IN and/or LOCAL_OUT targets.	DEBUG	move data from NORMAL to XR	DEBUG
ip_nat_init: can't setup rules.	DEBUG	moved %d buffers from NORMAL to XR, index	DEBUG
ip_nat_init: can't register in hook.	DEBUG	move buffers from XR to NORMAL	DEBUG
ip_nat_init: can't register out hook.	DEBUG	moved %d buffers from XR to NORMAL, count	DEBUG
ip_nat_init: can't register adjust in hook.	DEBUG	%s: %d %s, __FILE__, __LINE__, __func__	DEBUG
ip_nat_init: can't register adjust out hook.	DEBUG	%s: %d %s, __FILE__, __LINE__, __func__	DEBUG
ip_nat_init: can't register local out hook.	DEBUG	%s: no buffer (%s), dev->name, __func__	DEBUG
ip_nat_init: can't register local in hook.	DEBUG	%s: no skbuff (%s), dev->name, __func__	DEBUG
ipt_hook: happy cracking.	DEBUG	%s: HAL qnum %u out of range, max %u!,	DEBUG
ip_conntrack: can't register pre-routing defrag hook.	DEBUG	grppoll_start: grppoll Buf allocation failed	DEBUG
ip_conntrack: can't register local_out defrag hook.	DEBUG	%s: HAL qnum %u out of range, max %u!,	DEBUG
ip_conntrack: can't register pre-routing hook.	DEBUG	%s: AC %u out of range, max %u!,	DEBUG
ip_conntrack: can't register local out hook.	DEBUG	%s: unable to update hardware queue	DEBUG
ip_conntrack: can't register local in helper hook.	DEBUG	%s: bogus frame type 0x%x (%s), dev->name,	DEBUG
ip_conntrack: can't register postrouting helper hook.	DEBUG	ath_stoprecv: rx queue 0x%x, link %p,	DEBUG
ip_conntrack: can't register post-routing hook.	DEBUG	%s: %s: unable to reset channel %u (%u MHz)	DEBUG
ip_conntrack: can't register local in hook.	DEBUG	%s: %s: unable to restart recv logic,	DEBUG
ip_conntrack: can't register to sysctl.	DEBUG	%s: unable to allocate channel table, dev->name	DEBUG
ip_conntrack_rtsp v IP_NF_RTSP_VERSION loading	DEBUG	%s: unable to allocate channel table, dev->name	DEBUG
ip_conntrack_rtsp: max_outstanding must be a positive integer	DEBUG	%s: unable to collect channel list from HAL;	DEBUG
ip_conntrack_rtsp: setup_timeout must be a positive integer	DEBUG	R (%p %llx) %08x%08x %08x %08x %08x%08x %c,	DEBUG
ip_conntrack_rtsp: ERROR registering port %d, ports[i]	DEBUG	T (%p %llx) %08x%08x %08x %08x %08x%08x %08x %08x %c,	DEBUG
ip_nat_rtsp v IP_NF_RTSP_VERSION loading	DEBUG	%s: no memory for sysctl table!, __func__	DEBUG
%s: Sorry! Cannot find this match option., __FILE__	DEBUG	%s: no memory for device name storage!, __func__	DEBUG



ipt_time loading	DEBUG	%s: failed to register sysctl!, sc->sc_dev->name	DEBUG
ipt_time unloaded	DEBUG	%s: mac %d.%d phy %d.%d, dev->name,	DEBUG
ip_contrack_irc: max_dcc_channels must be a positive integer	DEBUG	5 GHz radio %d.%d 2 GHz radio %d.%d,	DEBUG
ip_contrack_irc: ERROR registering port %d,	DEBUG	radio %d.%d, ah->ah_analog5GhzRev >> 4,	DEBUG
ip_nat_h323: ip_nat_mangle_tcp_packet	DEBUG	radio %d.%d, ah->ah_analog5GhzRev >> 4,	DEBUG
ip_nat_h323: ip_nat_mangle_udp_packet	DEBUG	%s: Use hw queue %u for %s traffic,	DEBUG
ip_nat_h323: out of expectations	DEBUG	%s: Use hw queue %u for CAB traffic, dev->name,	DEBUG
ip_nat_h323: out of RTP ports	DEBUG	%s: Use hw queue %u for beacons, dev->name,	DEBUG
ip_nat_h323: out of TCP ports	DEBUG	Could not find Board Configuration Data	DEBUG
ip_nat_q931: out of TCP ports	DEBUG	Could not find Radio Configuration data	DEBUG
ip_nat_ras: out of TCP ports	DEBUG	ath_ahb: No devices found, driver not installed.	DEBUG
ip_nat_q931: out of TCP ports	DEBUG	_fmt, __VA_ARGS__	DEBUG
ip_contrack_core: Frag of proto %u.,	DEBUG	_fmt, __VA_ARGS__	DEBUG
Broadcast packet!	DEBUG	xlr8NatIpFinishOutput: Err.. skb2 == NULL!	DEBUG
Should bcast: %u.%u.%u.%u->%u.%u.%u.%u (sk=%p, ptype=%u),	DEBUG	xlr8NatSoftCtxEnqueue: Calling xlr8NatIpFinishOutput () ..., status	DEBUG
ip_contrack version %s (%u buckets, %d max)	DEBUG	xlr8NatSoftCtxEnqueue: xlr8NatIpFinishOutput () returned [%d], status	DEBUG
ERROR registering port %d,	DEBUG	icmpExceptionHandler: Exception!	DEBUG
netfilter PSD loaded - (c) astaro AG	DEBUG	fragExceptionHandler: Exception!	DEBUG
netfilter PSD unloaded - (c) astaro AG	DEBUG	algExceptionHandler: Exception!	DEBUG
%s , SELF	DEBUG	dnsExceptionHandler: Exception!	DEBUG
%s , LAN	DEBUG	IPsecExceptionHandler: Exception!	DEBUG
%s , WAN	DEBUG	ESP Packet Src:%x Dest:%x Sport:%d dport:%d secure:%d spi:%d isr:%p,	DEBUG
TRUNCATED	DEBUG	xlr8NatContrackPreHook: We found the valid context,	DEBUG
SRC=%u.%u.%u.%u DST=%u.%u.%u.%u ,	DEBUG	xlr8NatContrackPreHook: Not a secured packet.	DEBUG
LEN=%u TOS=0x%02X PREC=0x%02X TTL=%u ID=%u ,	DEBUG	xlr8NatContrackPreHook: isr=[%p], pls r	DEBUG
FRAG:%u , ntohs(ih->frag_off) & IP_OFFSET	DEBUG	xlr8NatContrackPreHook: secure=[%d], secure	DEBUG
TRUNCATED	DEBUG	Context found for ESP %p, pFlowEntry->post.plsr[0]	DEBUG
PROTO=TCP	DEBUG	xlr8NatContrackPreHook: New connection.	DEBUG
INCOMPLETE [%u bytes] ,	DEBUG	xlr8NatContrackPostHook: postSecure=[%d] postIsr=[%p %p],	DEBUG
SPT=%u DPT=%u ,	DEBUG	proto %d spi %d <-----> proto %d spi %d, pPktInfo->proto, pPktInfo->spi,	DEBUG
SEQ=%u ACK=%u ,	DEBUG	IPSEC_INF Clock skew detected	DEBUG

WINDOW=%u , ntohs(th->>window)	DEBUG	IPSEC_ERR [%s:%d]: Max (%d) No of SA Limit reached,	DEBUG
RES=0x%02x , (u8)(ntohl(tcp_flag_word(th) & TCP_RESERVED_BITS) >> 22)	DEBUG	IPSEC_ERR [%s:%d]: Max (%d) No of SA Limit reached,	DEBUG
URGP=%u , ntohs(th->urg_ptr)	DEBUG	IPSEC_ERR [%s:%d]: time(secs):%u	DEBUG
TRUNCATED	DEBUG	ERROR: Failed to add entry to IPsec sa table	DEBUG
%02X, op[i]	DEBUG	ERROR: Failed to add entry to IPsec sa table	DEBUG
PROTO=UDP	DEBUG	ERROR: Failed to add entry to IPsec sa table	DEBUG
INCOMPLETE [%u bytes] ,	DEBUG	ERROR: Failed to add entry to IPsec sa table	DEBUG
SPT=%u DPT=%u LEN=%u ,	DEBUG	ERROR: Failed to add entry to IPsec sa table	DEBUG
SPT=%u DPT=%u LEN=%u ,	DEBUG	ERROR: Failed to add entry to IPsec sa table	DEBUG
PROTO=ICMP	DEBUG	unknown oid '%s', varName	DEBUG
INCOMPLETE [%u bytes] ,	DEBUG	could not find oid pointer for '%s', varName	DEBUG
TYPE=%u CODE=%u , ich->type, ich->code	DEBUG	unRegistering IPsecMib .....	DEBUG
INCOMPLETE [%u bytes] ,	DEBUG	ERROR: Failed to add entry to IPsec sa table	DEBUG
ID=%u SEQ=%u ,	DEBUG	ERROR: Failed to add entry to IPsec sa table	DEBUG
PARAMETER=%u ,	DEBUG	ERROR: Failed to add entry to IPsec sa table	DEBUG
GATEWAY=%u.%u.%u.%u ,	DEBUG	ERROR: Failed to add entry to IPsec sa table	DEBUG
MTU=%u , ntohs(ich->un.frag.mtu)	DEBUG	ERROR: Failed to add entry to IPsec sa table	DEBUG
PROTO=AH	DEBUG	ERROR: Failed to add entry to IPsec sa table	DEBUG
INCOMPLETE [%u bytes] ,	DEBUG	unknown oid '%s', varName	DEBUG
SPI=0x%x , ntohl(ah->spi)	DEBUG	could not find oid pointer for '%s', varName	DEBUG
PROTO=ESP	DEBUG	unRegistering IPsecMib .....	DEBUG
INCOMPLETE [%u bytes] ,	DEBUG	. %u.%u.%u.%u, NIPQUAD(trt->rt_dst)	DEBUG
SPI=0x%x , ntohl(eh->spi)	DEBUG	%02x, *p	DEBUG
PROTO=%u , ih->protocol	DEBUG	. %u.%u.%u.%u, NIPQUAD(trt->rt_dst)	DEBUG
UID=%u , skb->sk->sk_socket->file->f_uid	DEBUG	%02x, *p	DEBUG
<%d>%sIN=%s OUT=%s , loginfo->u.log.level,	DEBUG	. %u.%u.%u.%u, NIPQUAD(trt->rt_dst)	DEBUG
level_string	DEBUG	%02x, *p	DEBUG
%sIN=%s OUT=%s ,	DEBUG	. %u.%u.%u.%u, NIPQUAD(trt->rt_dst)	DEBUG
%s , prefix == NULL ? loginfo->prefix: prefix	DEBUG	%02x, *p	DEBUG
IN=	DEBUG	unable to register vIPsec kernel comp to UMI	DEBUG
OUT=	DEBUG	unregistering VIPSECK from UMI ....	DEBUG
PHYSIN=%s , physindev->name	DEBUG	in vIPsecKloctlHandler cmd - %d, cmd	DEBUG

PHYSOUT=%s , physoutdev->name	DEBUG	%s: Error. DST Refcount value less than 1 (%d),	DEBUG
MAC=	DEBUG	for %s DEVICE refcnt: %d ,pDst->dev->name,	DEBUG
%02x%c, *p,	DEBUG	%s: Got Null m:%p *m:%p sa:%p *sa:%p, __func__, ppBufMgr,	DEBUG
NAT: no longer support implicit source local NAT	DEBUG	%s Got Deleted SA:%p state:%d, __func__, pIPsecInfo, pIPsecInfo->state	DEBUG
NAT: packet src %u.%u.%u.%u -> dst %u.%u.%u.%u,	DEBUG	%s: %s: fmt, __FILE__, __FUNCTION__, ## args)	INFO
SNAT: multiple ranges no longer supported	DEBUG	%s: %s: fmt, __FILE__, __FUNCTION__, ## args)	INFO
format, ## args)	DEBUG	ipt_TIME: format, ## args)	INFO
version	DEBUG	IPT_ACCOUNT_NAME : checkentry() wrong parameters (not equals existing table parameters).	INFO
offset_before=%d, offset_after=%d, correction_pos=%u, x->offset_before, x->offset_after, x->correction_pos	DEBUG	IPT_ACCOUNT_NAME : checkentry() too big netmask.	INFO
ip_ct_h323:	DEBUG	IPT_ACCOUNT_NAME : checkentry() failed to allocate %zu for new table %s., sizeof(struct ipt_account_table), info->name	INFO
ip_ct_h323: incomplete TPKT (fragmented?)	DEBUG	IPT_ACCOUNT_NAME : checkentry() wrong network/netmask.	INFO
ip_ct_h245: decoding error: %s,	DEBUG	account: Wrong netmask given by netmask parameter (%i). Valid is 32 to 0., netmask	INFO
ip_ct_h245: packet dropped	DEBUG	IPT_ACCOUNT_NAME : checkentry() failed to create procs entry.	INFO
ip_ct_q931: decoding error: %s,	DEBUG	IPT_ACCOUNT_NAME : checkentry() failed to register match.	INFO
ip_ct_q931: packet dropped	DEBUG	failed to create procs entry .	INFO
ip_ct_ras: decoding error: %s,	DEBUG	MPPE/MPPC encryption/compression module registered	INFO
ip_ct_ras: packet dropped	DEBUG	MPPE/MPPC encryption/compression module unregistered	INFO
ERROR registering port %d,	DEBUG	PPP generic driver version PPP_VERSION	INFO
ERROR registering port %d,	DEBUG	MPPE/MPPC encryption/compression module registered	INFO
ipt_connlimit[%d]: src=%u.%u.%u.%u:%d dst=%u.%u.%u.%u:%d %s,	DEBUG	MPPE/MPPC encryption/compression module unregistered	INFO
ipt_connlimit[%d]: src=%u.%u.%u.%u:%d dst=%u.%u.%u.%u:%d new,	DEBUG	PPP generic driver version PPP_VERSION	INFO
ipt_connlimit: Oops: invalid ct state ?	DEBUG	PPPoL2TP kernel driver, %s,	INFO
ipt_connlimit: Hmm, kmalloc failed :-(	DEBUG	PPPoL2TP kernel driver, %s,	INFO
ipt_connlimit: src=%u.%u.%u.%u mask=%u.%u.%u.%u	DEBUG	PPPoL2TP kernel driver, %s,	INFO
_M PPPOL2TP: _fmt, ## args	DEBUG	failed to create procs entry .	INFO
%02X, ptr[length]	DEBUG	proc dir not created ..	INFO
%02X, ((unsigned char *) m-	DEBUG	Initializing Product Data modules	INFO

>msg_iov[i].iov_base][j]			
%02X, skb->data[i]	DEBUG	De initializing by \	INFO
_lM PPPOL2TP: _fmt, ##args	DEBUG	kernel UMI module loaded	INFO
%02X, ptr[length]	DEBUG	kernel UMI module unloaded	INFO
%02X, ((unsigned char *) m->msg_iov[i].iov_base)[j]	DEBUG	Loading bridge module	INFO
%02X, skb->data[i]	DEBUG	Unloading bridge module	INFO
_lM PPPOL2TP: _fmt, ##args	DEBUG	unsupported command %d, cmd	INFO
%02X, ptr[length]	DEBUG	Loading ifDev module	INFO
%02X, ((unsigned char *) m->msg_iov[i].iov_base)[j]	DEBUG	Unloading ifDev module	INFO
%02X, skb->data[i]	DEBUG	ERROR#%d in alloc_chrdev_region, result	INFO
KERN_EMERG THE value read is %d,value*/	DEBUG	ERROR#%d in cdev_add, result	INFO
KERN_EMERG Factory Reset button is pressed	DEBUG	using bcm switch %s, bcmswitch	INFO
KERN_EMERG Returing error in INTR registration	DEBUG	privlegedID %d wanporttNo: %d, privlegedID,wanportNo	INFO
KERN_EMERG Initialzing Factory defaults modules	DEBUG	Loading mii	INFO
Failed to allocate memory for pSipListNode	DEBUG	Unloading mii	INFO
SIPALG: Memeory allocation failed for pSipNodeEntryTbl	DEBUG	%s: Version 0.1	INFO
pkt-err %s, pktInfo.error	DEBUG	%s: driver unloaded, dev_info wlan: %s backend registered, be->iab_name	INFO
pkt-err %s, pktInfo.error	DEBUG	wlan: %s backend unregistered,	INFO
pkt-err %s, pktInfo.error	DEBUG	wlan: %s acl policy registered, iac->iac_name	INFO
%s Len=%d, msg, len	DEBUG	wlan: %s acl policy unregistered, iac->iac_name	INFO
%02x, ((uint8_t*) ptr)[i]	DEBUG	%s, tmpbuf	INFO
End	DEBUG		INFO
CVM_MOD_EXP_BASE MISMATCH cmd=%x base=%x, cmd,	DEBUG	VLAN2	INFO
op->sizeofptr = %ld, op->sizeofptr	DEBUG	VLAN3	INFO
opcode cmd = %x, cmd	DEBUG	VLAN4 <%d %d>,	INFO
modexp opcode received	DEBUG	%s: %s, dev_info, version	INFO
Memory Allocation failed	DEBUG	%s: driver unloaded, dev_info	INFO
modexpcrt opcode received	DEBUG	%s, buf	INFO
kmalloc failed	DEBUG	%s: %s (, dev_info, ath_hal_version	INFO
kmalloc failed	DEBUG	%s: driver unloaded, dev_info	INFO
kmalloc failed	DEBUG	%s: %s: mem=0x%lx, irq=%d hw_base=0x%p,	INFO
kmalloc failed	DEBUG	%s: %s, dev_info, version	INFO
kmalloc Failed	DEBUG	%s: driver unloaded, dev_info	INFO
kmalloc failed	DEBUG	%s: %s: mem=0x%lx, irq=%d,	INFO
unknown cyrpto ioctl cmd received %x, cmd	DEBUG	%s: %s: mem=0x%lx, irq=%d,	INFO
register_chrdev returned ZERO	DEBUG	%s: %s, dev_info, version	INFO
const char *descr, krb5_keyblock *k) {	DEBUG	%s: driver unloaded, dev_info	INFO
F password, &pdata	DEBUG	%s, buf	INFO

test key, key	DEBUG	%s: %s (, dev_info, ath_hal_version	INFO
pre-hashed key, key	DEBUG	%s: driver unloaded, dev_info	INFO
const char *descr, krb5_keyblock *k) {	DEBUG	%s: driver unloaded, dev_info	INFO
AES 128-bit key, &key	DEBUG	%s: Version 2.0.0	INFO
const char *descr, krb5_keyblock *k) {	DEBUG	%s: driver unloaded, dev_info	INFO
test key, key	DEBUG	%s: driver unloaded, dev_info	INFO
pre-hashed key, key	DEBUG	wlan: %s backend registered, be->iab_name	INFO
const char *descr, krb5_keyblock *k) {	DEBUG	wlan: %s backend unregistered,	INFO
128-bit AES key, &dk	DEBUG	wlan: %s acl policy registered, iac->iac_name	INFO
256-bit AES key, &dk	DEBUG	wlan: %s acl policy unregistered, iac->iac_name	INFO
WARNING:	DEBUG	%s: %s, dev_info, version	INFO
bwMonMultipathNxtHopSelect:: checking rates	DEBUG	%s: driver unloaded, dev_info	INFO
hop :%d dev:%s usableBwLimit=%d currBwShare = %d lastHopSelected = %d weightedHopPrefer = %d ,	DEBUG	%s: %s (, dev_info, ath_hal_version	INFO
1. selecting hop: %d lastHopSelected = %d , selHop, lastHopSelected	DEBUG	%s: driver unloaded, dev_info	INFO
4. hop :%d dev:%s usableBwLimit=%d currBwShare = %d lastHopSelected = %d weightedHopPrefer = %d ,	DEBUG	%s: %s: mem=0x%lx, irq=%d,	INFO
2. selecting hop: %d lastHopSelected = %d , selHop, lastHopSelected	DEBUG	%s: %s, dev_info, version	INFO
3. selecting hop: %d lastHopSelected = %d , selHop, lastHopSelected	DEBUG	%s: driver unloaded, dev_info	INFO
bwMonitor multipath selection enabled	DEBUG	ath_pci: switching rfkill capability %s,	INFO
bwMonitor multipath selection disabled	DEBUG	Unknown autocreate mode: %s,	INFO
weightedHopPrefer set to %d , weightedHopPrefer	DEBUG	%s: %s: mem=0x%lx, irq=%d,	INFO
bwMonitor sysctl registration failed	DEBUG	%s: %s, dev_info, version	INFO
bwMonitor sysctl registered	DEBUG	%s: driver unloaded, dev_info	INFO
bwMonitor sysctl not registered	DEBUG	%s: %s, dev_info, version	INFO
Unregistered bwMonitor sysctl	DEBUG	%s: unloaded, dev_info	INFO
CONFIG_SYSCTL enabled ...	DEBUG	%s: %s, dev_info, version	INFO
Initialized bandwidth monitor ...	DEBUG	%s: unloaded, dev_info	INFO
Removed bandwidth monitor ...	DEBUG	%s: %s, dev_info, version	INFO
Oops.. AES_GCM_encrypt failed (keylen:%u), key->cvm_keylen	DEBUG	%s: unloaded, dev_info	INFO
Oops.. AES_GCM_decrypt failed (keylen:%u), key->cvm_keylen	DEBUG	failed to create procs entry .	INFO
%s, msg	DEBUG	ICMP: %u.%u.%u.%u:	INFO
%02x%s, data[i],	DEBUG	ICMP: %u.%u.%u.%u: Source	INFO
Failed to set AES encrypt key	DEBUG	Wrong address mask %u.%u.%u.%u from	INFO
Failed to set AES encrypt key	DEBUG	Redirect from %u.%u.%u.%u on %s about	INFO
AES %s Encrypt Test Duration: %d:%d, hard ? Hard : Soft,	DEBUG	IP: routing cache hash table of %u buckets, %ldKbytes,	INFO
Failed to set AES encrypt key	DEBUG	source route option %u.%u.%u.%u -> %u.%u.%u.%u,	INFO

Failed to set AES encrypt key	DEBUG	ICMP: %u.%u.%u.%u:	INFO
AES %s Decrypt Test Duration: %d:%d, hard ? Hard : Soft,	DEBUG	ICMP: %u.%u.%u.%u: Source	INFO
Failed to set AES encrypt key	DEBUG	Wrong address mask %u.%u.%u.%u from	INFO
Failed to set AES encrypt key	DEBUG	Redirect from %u.%u.%u.%u on %s about	INFO
Failed to set AES encrypt key	DEBUG	IP: routing cache hash table of %u buckets, %ldKbytes,	INFO
Failed to set AES encrypt key	DEBUG	source route option %u.%u.%u.%u -> %u.%u.%u.%u,	INFO
Failed to set DES encrypt key[%d], i	DEBUG	Wrong address mask %u.%u.%u.%u from	INFO
Failed to set DES decrypt key[%d], i	DEBUG	Redirect from %u.%u.%u.%u on %s about	INFO
Failed to set DES encrypt key[%d], i	DEBUG	source route option	INFO
Failed to set DES decrypt key[%d], i	DEBUG	ICMP: %u.%u.%u.%u:	INFO
Failed to set DES encrypt key	DEBUG	ICMP: %u.%u.%u.%u: Source	INFO
Failed to set DES decrypt key	DEBUG	Wrong address mask %u.%u.%u.%u from	INFO
Failed to set DES encrypt key	DEBUG	Redirect from %u.%u.%u.%u on %s about	INFO
Failed to set DES decrypt key	DEBUG	IP: routing cache hash table of %u buckets, %ldKbytes,	INFO
AES Software Test:	DEBUG	source route option %u.%u.%u.%u -> %u.%u.%u.%u,	INFO
AES Software Test %s, aesSoftTest(0) ? Failed : Passed	DEBUG	IPsec: device unregistering: %s, dev->name	INFO
AES Hardware Test:	DEBUG	IPsec: device down: %s, dev->name	INFO
AES Hardware Test %s, aesHardTest(0) ? Failed : Passed	DEBUG	mark: only supports 32bitmark	WARNING
3DES Software Test:	DEBUG	ipt_time: invalid argument	WARNING
3DES Software Test %s, des3SoftTest(0) ? Failed : Passed	DEBUG	ipt_time: IPT_DAY didn't matched	WARNING
3DES Hardware Test:	DEBUG	./Logs_kernel.txt:45:KERN_WARNING	WARNING
3DES Hardware Test %s, des3HardTest(0) ? Failed : Passed	DEBUG	./Logs_kernel.txt:59:KERN_WARNING	WARNING
DES Software Test:	DEBUG	ipt_LOG: not logging via system console	WARNING
DES Software Test %s, desSoftTest(0) ? Failed : Passed	DEBUG	%s: wrong options length: %u, fname, opt_len	WARNING
DES Hardware Test:	DEBUG	%s: options rejected: o[0]=%02x, o[1]=%02x,	WARNING
DES Hardware Test %s, desHardTest(0) ? Failed : Passed	DEBUG	%s: wrong options length: %u,	WARNING
SHA Software Test:	DEBUG	%s: options rejected: o[0]=%02x, o[1]=%02x,	WARNING
SHA Software Test %s, shaSoftTest(0) ? Failed : Passed	DEBUG	%s: don't know what to do: o[5]=%02x,	WARNING
SHA Hardware Test:	DEBUG	%s: wrong options length: %u, fname, opt_len	WARNING
SHA Hardware Test %s, shaHardTest(0) ? Failed : Passed	DEBUG	%s: options rejected: o[0]=%02x, o[1]=%02x,	WARNING
MD5 Software Test:	DEBUG	%s: wrong options length: %u,	WARNING

MD5 Software Test %s, md5SoftTest(0) ? Failed : Passed	DEBUG	%s: options rejected: o[0]=%02x, o[1]=%02x,	WARNIN G
MD5 Hardware Test:	DEBUG	%s: don't know what to do: o[5]=%02x,	WARNIN G
MD5 Hardware Test %s, md5HardTest(0) ? Failed : Passed	DEBUG	*** New port %d *** , ntohs(expinfo- >natport)	WARNIN G
AES Software Test: %d iterations, iter	DEBUG	** skb len %d, dlen %d, (*pskb)->len,	WARNIN G
AES Software Test Duration: %d:%d,	DEBUG	***** Non linear skb	WARNIN G
AES Hardware Test: %d iterations, iter	DEBUG	End of sdp %p, nexthdr	WARNIN G
AES Hardware Test Duration: %d:%d,	DEBUG	%s: unknown pairwise cipher %d,	WARNIN G
3DES Software Test: %d iterations, iter	DEBUG	%s: unknown group cipher %d,	WARNIN G
3DES Software Test Duration: %d:%d,	DEBUG	%s: unknown SIOCSIWAUTH flag %d,	WARNIN G
3DES Hardware Test: %d iterations, iter	DEBUG	%s: unknown SIOCGIWAUTH flag %d,	WARNIN G
3DES Hardware Test Duration: %d:%d,	DEBUG	%s: unknown algorithm %d,	WARNIN G
DES Software Test: %d iterations, iter	DEBUG	%s: key size %d is too large,	WARNIN G
DES Software Test Duration: %d:%d,	DEBUG	try_module_getfailed \	WARNIN G
DES Hardware Test: %d iterations, iter	DEBUG	%s: request_irq failed, dev->name	WARNIN G
DES Hardware Test Duration: %d:%d,	DEBUG	try_module_getfailed	WARNIN G
SHA Software Test: %d iterations, iter	DEBUG	try_module_getfailed \	WARNIN G
SHA Software Test Duration: %d:%d,	DEBUG	%s: unknown pairwise cipher %d,	WARNIN G
SHA Hardware Test: %d iterations, iter	DEBUG	%s: unknown group cipher %d,	WARNIN G
SHA Hardware Test Duration: %d:%d,	DEBUG	%s: unknown SIOCSIWAUTH flag %d,	WARNIN G
MD5 Software Test: %d iterations, iter	DEBUG	%s: unknown SIOCGIWAUTH flag %d,	WARNIN G
MD5 Software Test Duration: %d:%d,	DEBUG	%s: unknown algorithm %d,	WARNIN G
MD5 Hardware Test: %d iterations, iter	DEBUG	%s: key size %d is too large,	WARNIN G
MD5 Hardware Test Duration: %d:%d,	DEBUG	unable to load %s, scan_modnames[mode]	WARNIN G
./pnac/src/pnac/linux/kernel/xcalibur.c:2 09:#define DEBUG_PRINTK printk	DEBUG	Failed to mkdir /proc/net/madwifi	WARNIN G
bcmDeviceInit: registration failed	DEBUG	try_module_getfailed	WARNIN G
bcmDeviceInit: pCdev Add failed	DEBUG	%s: request_irq failed, dev->name too many virtual ap's (already got %d), sc->sc_nvaps	WARNIN G
REG Size == 8 Bit	DEBUG	%s: request_irq failed, dev->name	WARNIN G
Value = %x ::: At Page = %x : Addr = %x	DEBUG	rix %u (%u) bad ratekbps %u mode %u,	WARNIN G
REG Size == 16 Bit	DEBUG		WARNIN G

Value = %x ::: At Page = %x : Addr = %x	DEBUG	cix %u (%u) bad ratekbps %u mode %u,	WARNING
REG Size == 32 Bit	DEBUG	%s: no rates for %s?,	WARNING
Value = %x ::: At Page = %x : Addr = %x	DEBUG	no rates yet! mode %u, sc->sc_curmode	WARNING
REG Size == 64 Bit	DEBUG	%u.%u.%u.%u sent an invalid ICMP	WARNING
REG Size is not in 8/16/32/64	DEBUG	dst cache overflow	WARNING
Written Value = %x ::: At Page = %x : Addr = %x	DEBUG	Neighbour table overflow.	WARNING
bcm_ioctl :Unknown ioctl Case :	DEBUG	host %u.%u.%u.%u/iface %d ignores	WARNING
====Register Dump for Port Number # %d====,port	DEBUG	martian destination %u.%u.%u.%u from	WARNING
%s : Read Status=%s data=%#x,regName[j],	DEBUG	martian source %u.%u.%u.%u from	WARNING
%s : Read Status=%s data=%#x,regName[j],	DEBUG	ll header:	WARNING
powerDeviceInit: device registration failed	DEBUG	%u.%u.%u.%u sent an invalid ICMP	WARNING
powerDeviceInit: adding device failed	DEBUG	dst cache overflow	WARNING
%s: Error: Big jump in pn number. TID=%d, from %x %x to %x %x.	DEBUG	Neighbour table overflow.	WARNING
%s: The MIC is corrupted. Drop this frame., __func__	DEBUG	host %u.%u.%u.%u/iface %d ignores	WARNING
%s: The MIC is OK. Still use this frame and update PN., __func__	DEBUG	martian destination %u.%u.%u.%u from	WARNING
ADDBA send failed: recipient is not a 11n node	DEBUG	martian source %u.%u.%u.%u from	WARNING
Cannot Set Rate: %x, value	DEBUG	ll header:	WARNING
Getting Rate Series: %x,vap->iv_fixed_rate.series	DEBUG	%u.%u.%u.%u sent an invalid ICMP	WARNING
Getting Retry Series: %x,vap->iv_fixed_rate.retries	DEBUG	dst cache overflow	WARNING
IC Name: %s,ic->ic_dev->name	DEBUG	Neighbour table overflow.	WARNING
usage: rtparams rt_idx <0 1> per <0..100> probe_intval <0..100>	DEBUG	host %u.%u.%u.%u/iface %d ignores	WARNING
usage: acparams ac <0 3> RTS <0 1> aggr scaling <0..4> min mbps <0..250>	DEBUG	martian source %u.%u.%u.%u from	WARNING
usage: hbrparams ac <2> enable <0 1> per_low <0..50>	DEBUG	ll header:	WARNING
%s(): ADDBA mode is AUTO, __func__	DEBUG	martian destination %u.%u.%u.%u from	WARNING
%s(): Invalid TID value, __func__	DEBUG	%u.%u.%u.%u sent an invalid ICMP	WARNING
%s(): ADDBA mode is AUTO, __func__	DEBUG	dst cache overflow	WARNING
%s(): Invalid TID value, __func__	DEBUG	Neighbour table overflow.	WARNING
%s(): Invalid TID value, __func__	DEBUG	host %u.%u.%u.%u/iface %d ignores	WARNING
Addba status IDLE	DEBUG	martian destination %u.%u.%u.%u	WARNING





[%d]\tMacAddr\t%s, j,	DEBUG	PPP: no memory (VJ comp pkt)	ERROR
[%d]\tDescp\t\t%s, j, ni->node_trace[i].descp	DEBUG	PPP: no memory (comp pkt)	ERROR
[%d]\tValue\t\t%llu(0x%llx), j, ni->node_trace[i].value,	DEBUG	ppp: compressor dropped pkt	ERROR
ifmedia_add: null ifm	DEBUG	PPP: no memory (fragment)	ERROR
Adding entry for	DEBUG	PPP: VJ uncompressed error	ERROR
ifmedia_set: no match for 0x%x/0x%x,	DEBUG	ppp_decompress_frame: no memory	ERROR
ifmedia_set: target	DEBUG	ppp_mp_reconstruct bad seq %u < %u,	ERROR
ifmedia_set: setting to	DEBUG	PPP: couldn't register device %s (%d),	ERROR
ifmedia_ioctl: switching %s to , dev->name	DEBUG	ppp: destroying ppp struct %p but dead=%d	ERROR
ifmedia_match: multiple match for	DEBUG	ppp: destroying undead channel %p !,	ERROR
<unknown type>	DEBUG	PPP: removing module but units remain!	ERROR
desc->ifmt_string	DEBUG	PPP: failed to unregister PPP device	ERROR
mode %s, desc->ifmt_string	DEBUG	%s: cannot allocate space for %s compressor, fname,	ERROR
<unknown subtype>	DEBUG	%s: cannot allocate space for MPPC history,	ERROR
%s, desc->ifmt_string	DEBUG	%s: cannot allocate space for MPPC history,	ERROR
%s %s, seen_option++ ? , : ,	DEBUG	%s: cannot load ARC4 module, fname	ERROR
%s %s, seen_option++ ? , : ,	DEBUG	%s: cannot load SHA1 module, fname	ERROR
%s, seen_option ? > :	DEBUG	%s: CryptoAPI SHA1 digest size too small, fname	ERROR
%s: %s, dev->name, buf	DEBUG	%s: cannot allocate space for SHA1 digest, fname	ERROR
%s: no memory for sysctl table!, __func__	DEBUG	%s%d: trying to write outside history	ERROR
%s: failed to register sysctls!, vap->iv_dev->name	DEBUG	%s%d: trying to write outside history	ERROR
Atheros HAL assertion failure: %s: line %u: %s,	DEBUG	%s%d: trying to write outside history	ERROR
ath_hal: logging to %s %s, ath_hal_logfile,	DEBUG	%s%d: too big uncompressed packet: %d,	ERROR
ath_hal: logging disabled	DEBUG	%s%d: encryption negotiated but not an	ERROR
%s %s, sep, ath_hal_buildopts[i]	DEBUG	%s%d: error - not an MPPC or MPPE frame	ERROR
ath_pci: No devices found, driver not installed.	DEBUG	Kernel doesn't provide ARC4 and/or SHA1 algorithms	ERROR
---:%d pri:%d qd:%u ad:%u sd:%u tot:%u amp:%d %02x:%02x:%02x,	DEBUG	PPP: not interface or channel??	ERROR
SC Pushbutton Notify on %s::%s, dev->name, vap->iv_dev->name	DEBUG	PPP: no memory (VJ compressor)	ERROR
Could not find Board Configuration Data	DEBUG	failed to register PPP device (%d), err	ERROR
Could not find Radio Configuration data	DEBUG	PPP: no memory (comp pkt)	ERROR
%s: No device, __func__	DEBUG	ppp: compressor dropped pkt	ERROR
ath_ahb: No devices found, driver not installed.	DEBUG	PPP: no memory (VJ comp pkt)	ERROR
PKTLOG_TAG %s:proc_dointvec failed, __FUNCTION__	DEBUG	PPP: no memory (comp pkt)	ERROR
PKTLOG_TAG %s:proc_dointvec failed,	DEBUG	PPP: no memory (fragment)	ERROR

__FUNCTION__			
%s: failed to register sysctls!, proc_name	DEBUG	PPP: VJ uncompressed error	ERROR
PKTLOG_TAG %s: proc_mkdir failed, __FUNCTION__	DEBUG	ppp_decompress_frame: no memory	ERROR
PKTLOG_TAG %s: pktlog_attach failed for %s,	DEBUG	ppp_mp_reconstruct bad seq %u < %u,	ERROR
PKTLOG_TAG %s: allocation failed for pl_info, __FUNCTION__	DEBUG	PPP: couldn't register device %s (%d),	ERROR
PKTLOG_TAG %s: allocation failed for pl_info, __FUNCTION__	DEBUG	ppp: destroying ppp struct %p but dead=%d	ERROR
PKTLOG_TAG %s: create_proc_entry failed for %s,	DEBUG	ppp: destroying undead channel %p !,	ERROR
PKTLOG_TAG %s: sysctl register failed for %s,	DEBUG	PPP: removing module but units remain!	ERROR
PKTLOG_TAG %s: page fault out of range, __FUNCTION__	DEBUG	PPP: failed to unregister PPP device	ERROR
PKTLOG_TAG %s: page fault out of range, __FUNCTION__	DEBUG	JBD: bad block at offset %u,	ERROR
PKTLOG_TAG %s: Log buffer unavailable, __FUNCTION__	DEBUG	JBD: corrupted journal superblock	ERROR
PKTLOG_TAG	DEBUG	JBD: bad block at offset %u,	ERROR
Logging should be disabled before changing bufer size	DEBUG	JBD: Failed to read block at offset %u,	ERROR
%s: allocation failed for pl_info, __func__	DEBUG	JBD: error %d scanning journal, err	ERROR
%s: Unable to allocate buffer, __func__	DEBUG	JBD: IO error %d recovering block	ERROR
%s: allocation failed for pl_info, __func__	DEBUG	./Logs_kernel.txt:303:KERN_ERR	ERROR
%s: Unable to allocate buffer, __func__	DEBUG	./Logs_kernel.txt:304:KERN_ERR	ERROR
Atheros HAL assertion failure: %s: line %u: %s,	DEBUG	JBD: recovery pass %d ended at	ERROR
ath_hal: logging to %s %s, ath_hal_logfile,	DEBUG	%s: %s: %d: BAD SESSION MAGIC \	ERROR
ath_hal: logging disabled	DEBUG	%s: %s: %d: BAD TUNNEL MAGIC \	ERROR
%s %s, sep, ath_hal_buildopts[]	DEBUG	msg->msg_namelen wrong, %d, msg-> msg_namelen	ERROR
failed to allocate rx descriptors: %d, error	DEBUG	addr family wrong: %d, usin-> sin_family	ERROR
ath_stoprecv: rx queue %p, link %p, no mpdu (%s), __func__	DEBUG	udp addr=%x%hu, usin-> sin_addr.s_addr, usin->sin_port	ERROR
Reset rx chain mask. Do internal reset. (%s), __func__	DEBUG	%s: %s: %d: BAD TUNNEL MAGIC	ERROR
OS_CANCEL_TIMER failed!!	DEBUG	socki_lookup: socket file changed!	ERROR
%s: unable to allocate channel table, __func__	DEBUG	%s: %s: %d: BAD TUNNEL MAGIC	ERROR
%s: unable to collect channel list from hal;	DEBUG	%s: %s: %d: BAD SESSION MAGIC \	ERROR
%s: cannot map channel to mode; freq %u flags 0x%x,	DEBUG	%s: %s: %d: BAD TUNNEL MAGIC \	ERROR
%s: unable to reset channel %u (%uMhz)	DEBUG	msg->msg_namelen wrong, %d, msg-> msg_namelen	ERROR
%s: unable to restart recv logic,	DEBUG	addr family wrong: %d, usin-> sin_family	ERROR
%s: start DFS WAIT period on channel %d, __func__, sc->sc_curchan.channel	DEBUG	udp addr=%x%hu, usin-> sin_addr.s_addr, usin->sin_port	ERROR

%s: cancel DFS WAIT period on channel %d, __func__, sc->sc_curchan.channel	DEBUG	%s:%s:%d: BAD TUNNEL MAGIC	ERROR
Non-DFS channel, cancelling previous DFS wait timer channel %d, sc->sc_curchan.channel	DEBUG	%s:%s:%d: BAD TUNNEL MAGIC	ERROR
%s: unable to reset hardware; hal status %u	DEBUG	socki_lookup: socket file changed!	ERROR
%s: unable to start recv logic, __func__	DEBUG	%s:%s:%d: BAD TUNNEL MAGIC	ERROR
%s: unable to start recv logic, __func__	DEBUG	%s:%s:%d: BAD SESSION MAGIC \	ERROR
%s: unable to reset hardware; hal status %u,	DEBUG	%s:%s:%d: BAD TUNNEL MAGIC \	ERROR
hardware error; resetting	DEBUG	msg->msg_namelen wrong, %d, msg->msg_namelen	ERROR
rx FIFO overrun; resetting	DEBUG	addr family wrong: %d, usin->sin_family	ERROR
%s: During Wow Sleep and got BMISS, __func__	DEBUG	udp addr=%x%hu, usin->sin_addr.s_addr, usin->sin_port	ERROR
AC\trts \tAggr Scaling\tMin Rate(Kbps)\tHBR \tPER LOW THRESHOLD	DEBUG	%s:%s:%d: BAD TUNNEL MAGIC	ERROR
BE\t%s\t\t%d\t\t6d\t\t%s\t\t%d,	DEBUG	%s:%s:%d: BAD TUNNEL MAGIC	ERROR
BK\t%s\t\t%d\t\t6d\t\t%s\t\t%d,	DEBUG	socki_lookup: socket file changed!	ERROR
VI\t%s\t\t%d\t\t6d\t\t%s\t\t%d,	DEBUG	%s:%s:%d: BAD TUNNEL MAGIC	ERROR
VO\t%s\t\t%d\t\t6d\t\t%s\t\t%d,	DEBUG	rebootHook: null function pointer	ERROR
--%d,%p,%lu:0x%x0x%x 0x%p 0x%x 0x%x 0x%x 0x%x,	DEBUG	Bad ioctl command	ERROR
bb state: 0x%08x 0x%08x, bbstate(sc, 4ul), bbstate(sc, 5ul)	DEBUG	fResetMod: Failed to configure gpio pin	ERROR
%08x%08x %08x %08x %08x %08x %08x%08x%08x %08x %08x %08x,	DEBUG	fResetMod: Failed to register interrupt handler	ERROR
noise floor: (%d, %d) (%d, %d) (%d, %d),	DEBUG	registering char device failed	ERROR
%p: %08x%08x %08x %08x %08x %08x %08x%08x%08x %08x %08x %08x %08x,	DEBUG	unregistering char device failed	ERROR
--%d,%p,%lu:0x%x0x%x 0x%p 0x%x 0x%x 0x%x 0x%x,	DEBUG	proc entry delete failed	ERROR
%08x%08x %08x %08x %08x %08x %08x%08x%08x %08x %08x %08x %08x,	DEBUG	proc entry initialization failed	ERROR
%s: unable to allocate device object, __func__	DEBUG	testCompHandler: received %s from %d, (char *)pInBuf,	ERROR
%s: unable to attach hardware; HAL status %u,	DEBUG	UMI proto registration failed %d,ret	ERROR
%s: HAL ABI mismatch;	DEBUG	AF_UMI registration failed %d,ret	ERROR
%s: Warning, using only %u entries in %u key cache,	DEBUG	umi initialization failed %d,ret	ERROR
unable to setup a beacon xmit queue!	DEBUG	kernel UMI registration failed!	ERROR
unable to setup CAB xmit queue!	DEBUG	./Logs_kernel.txt:447:KERN_ERR	ERROR
unable to setup xmit queue for BE traffic!	DEBUG	ERROR msm not found properly %d, len %d, msm,	ERROR
%s DFS attach failed, __func__	DEBUG	ModExp returned Error	ERROR
%s: Invalid interface id = %u, __func__, if_id	DEBUG	ModExp returned Error	ERROR
%s:grppoll Buf allocation failed	DEBUG	%s:0x%p len %u, tag, p, (unsigned	ERROR

__func__		int)len	
%s: unable to start recv logic,	DEBUG	%03d:, i	ERROR
%s: Invalid interface id = %u, __func__, if_id	DEBUG	%02x, ((unsigned char *)p)[i]	ERROR
%s: unable to allocate channel table, __func__	DEBUG	mic check failed	ERROR
%s: Tx Antenna Switch. Do internal reset., __func__	DEBUG	%s: 0x%p len %u, tag, p, (unsigned int)len	ERROR
Radar found on channel %d (%d MHz),	DEBUG	%03d:, i	ERROR
End of DFS wait period	DEBUG	%02x, ((unsigned char *)p)[i]	ERROR
%s error allocating beacon, __func__	DEBUG	mic check failed	ERROR
failed to allocate UAPSD QoS NULL tx descriptors: %d, error	DEBUG	[%s] Wrong parameters, __func__	ERROR
failed to allocate UAPSD QoS NULL wbuf	DEBUG	[%s] Wrong Key length, __func__	ERROR
%s: unable to allocate channel table, __func__	DEBUG	[%s] Wrong parameters, __func__	ERROR
%s: unable to update h/w beacon queue parameters,	DEBUG	[%s] Wrong Key length, __func__	ERROR
ALREADY ACTIVATED	DEBUG	[%s] Wrong parameters, __func__	ERROR
%s: missed %u consecutive beacons,	DEBUG	[%s] Wrong Key length, __func__	ERROR
%s: busy times: rx_clear=%d, rx_frame=%d, tx_frame=%d, __func__, rx_clear, rx_frame, tx_frame	DEBUG	[%s] Wrong parameters, __func__	ERROR
%s: unable to obtain busy times, __func__	DEBUG	[%s] Wrong Key length, __func__	ERROR
%s: beacon is officially stuck,	DEBUG	[%s]: Wrong parameters, __func__	ERROR
Busy environment detected	DEBUG	[%s] Wrong Key Length %d, __func__, des_key_len	ERROR
Inteference detected	DEBUG	[%s] Wrong parameters %d, __func__, des_key_len	ERROR
rx_clear=%d, rx_frame=%d, tx_frame=%d,	DEBUG	[%s] Wrong Key Length %d, __func__, des_key_len	ERROR
%s: resume beacon xmit after %u misses,	DEBUG	[%s] Wrong parameters, __func__	ERROR
%s: stuck beacon; resetting (bmiss count %u),	DEBUG	[%s] Wrong Key Length, __func__	ERROR
EMPTY QUEUE	DEBUG	[%s] Wrong parameters, __func__	ERROR
SWRInfo: seqno %d isswRetry%d retryCnt %d,wh ? (*(u_int16_t*)&wh->i_seq[0]) >> 4 : 0, bf->bf_isswretry,bf->bf_swretries	DEBUG	[%s] Wrong Key Length, __func__	ERROR
Buffer #%%08X --> Next%%08X Prev%%08X Last%%08X,bf, TAILQ_NEXT(bf,bf_list), Stas%%08Xflag%%08X	DEBUG	[%s] Wrong parameters, __func__	ERROR
Node%%08X,bf->bf_status, bf->bf_flags, bf->bf_node	DEBUG	[%s] Wrong parameters, __func__	ERROR
Descr #%%08X --> Next%%08X Data%%08XCtl0%%08X Ctl1%%08X, bf->bf_daddr, ds->ds_link, ds->ds_data, ds->ds_ctl0, ds->ds_ctl1 Ctl2%%08XCtl3%%08X	DEBUG	[%s] Wrong parameters, __func__	ERROR
Sta0%%08X Sta1 #%%08X,ds->ds_hw[0], ds->ds_hw[1], lastds->ds_hw[2], lastds->ds_hw[3]	DEBUG	[%s] Wrong parameters, __func__	ERROR
Error entering wow mode	DEBUG	device name=%s not found, pReq-	ERROR

		>ifName	
Wakingup due to wow signal	DEBUG	unable to register KIFDEV to UMI	ERROR
%s, wowStatus = 0x%x, __func__, wowStatus	DEBUG	ERROR: %s: Timeout at page %#0x addr %#0x	ERROR
Pattern added already	DEBUG	ERROR: %s: Timeout at page %#0x addr %#0x	ERROR
Error : All the %d pattern are in use. Cannot add a new pattern , MAX_NUM_PATTERN	DEBUG	Invalid IOCTL %#08x, cmd	ERROR
Pattern added to entry %d ,i	DEBUG	%s: unable to register device, dev->name	ERROR
Remove wake up pattern	DEBUG	ath_pci: 32-bit DMA not available	ERROR
mask = %p pat = %p ,maskBytes ,patternBytes	DEBUG	ath_pci: cannot reserve PCI memory region	ERROR
mask = %x pat = %x ,(u_int32_t)maskBytes, (u_int32_t)patternBytes	DEBUG	ath_pci: cannot remap PCI memory region);	ERROR
Pattern Removed from entry %d ,i	DEBUG	ath_pci: no memoryfor device state	ERROR
Error : Pattern not found	DEBUG	%s: unable to register device, dev->name	ERROR
PPM STATE ILLEGAL %x %x, forcePpmStateCur, afp->forceState	DEBUG	ath_dev_probe: no memoryfor device state	ERROR
FORCE_PPM %4d %6.6x %8.8x %8.8x %8.8x %3.3x %4.4x,	DEBUG	%s: no memoryfor device state, __func__	ERROR
failed to allocate tx descriptors: %d, error	DEBUG	kernel MIBCTL registration failed!	ERROR
failed to allocate beacon descriptors: %d, error	DEBUG	Bad ioctl command	ERROR
failed to allocate UAPSD descriptors: %d, error	DEBUG	WpsMod: Failed to configure gpio pin	ERROR
hal qnum %u out of range, max %u!,	DEBUG	WpsMod: Failed to register interrupt handler	ERROR
HAL AC %u out of range, max %zu!,	DEBUG	registering char device failed	ERROR
HAL AC %u out of range, max %zu!,	DEBUG	unregistering char device failed	ERROR
%s: unable to update hardware queue %u!,	DEBUG	%s:%d - ERROR: non-NULL node pointer in %p, %p<%s>!	ERROR
Multicast Q:	DEBUG	%s:%d - ERROR: non-NULL node pointer in %p, %p<%s>!	ERROR
%p , buf	DEBUG	can't alloc name %s, name	ERROR
buf flags - 0x%08x ----- , buf->bf_flags	DEBUG	%s: unable to register device, dev->name	ERROR
buf status - 0x%08x, buf->bf_status	DEBUG	failed to automatically load module: %s; \	ERROR
# frames in aggr - %d, length of aggregate - %d, length of frame - %d, sequence number - %d, tidno - %d,	DEBUG	Unable to load needed module: %s; no support for \	ERROR
isdata: %d isaggr: %d isampdu: %d ht: %d isretried: %d isxretried: %d shpreamble: %d isbar: %d ispoll: %d aggrburst: %d calcairtime: %d qosnulleosp: %d,	DEBUG	Module %s\ is not known, buf	ERROR
%p: 0x%08x 0x%08x 0x%08x 0x%08x 0x%08x 0x%08x 0x%08x 0x%08x 0x%08x 0x%08x 0x%08x 0x%08x 0x%08x 0x%08x,	DEBUG	Error loading module %s\, buf	ERROR
0x%08x 0x%08x 0x%08x 0x%08x 0x%08x 0x%08x 0x%08x 0x%08x 0x%08x 0x%08x 0x%08x 0x%08x 0x%08x 0x%08x	DEBUG	Module %s\ failed to initialize, buf	ERROR

0x%08x 0x%08x,			
0x%08x 0x%08x 0x%08x 0x%08x,	DEBUG	ath_pci: 32-bit DMA not available	ERROR
sc_txq[%d] : , i	DEBUG	ath_pci: cannot reserve PCI memory region	ERROR
tid %p pause %d : , tid, tid->paused	DEBUG	ath_pci: cannot remap PCI memory region);	ERROR
%d: %p , j, tid->tx_buffj]	DEBUG	ath_pci: no memoryfor device state	ERROR
%p , buf	DEBUG	%s: unable to attach hardware: '%s' (HAL status %u),	ERROR
axq_q:	DEBUG	%s: HAL ABI mismatch;	ERROR
%s: unable to reset hardware; hal status %u, __func__, status	DEBUG	%s: failed to allocate descriptors: %d,	ERROR
****ASSERTION HIT****	DEBUG	%s: unable to setup a beacon xmit queue!,	ERROR
MacAddr=%s,	DEBUG	%s: unable to setup CAB xmit queue!,	ERROR
TxBufIdx=%d, i	DEBUG	%s: unable to setup xmit queue for %s traffic!,	ERROR
Tid=%d, tidno	DEBUG	%s: unable to register device, dev->name	ERROR
AthBuf=%p, tid->tx_buff[i]	DEBUG	%s: autocreation of VAP failed: %d,	ERROR
%s: unable to reset hardware; hal status %u,	DEBUG	ath_dev_probe: no memoryfor device state	ERROR
%s: unable to reset hardware; hal status %u,	DEBUG	kdot11RogueAPEnable called with NULL argument.	ERROR
%s: unable to start recv logic,	DEBUG	kdot11RogueAPEnable: can not add more interfaces	ERROR
_fmt, __VA_ARGS__ \	DEBUG	kdot11RogueAPGetState called with NULL argument.	ERROR
sample_pri=%d is a multiple of refpri=%d, sample_pri, refpri	DEBUG	kdot11RogueAPDisable called with NULL argument.	ERROR
===== ft->ft_numfilters=%u===== ft->ft_numfilters	DEBUG	%s: SKB does not exist., __FUNCTION__	ERROR
filter[%d] filterID = %d rf_numpulses=%u; rf->rf_minpri=%u; rf->rf_maxpri=%u; rf->rf_threshold=%u; rf->rf_filterlen=%u; rf->rf_mindur=%u; rf->rf_maxdur=%u,j, rf->rf_pulseid,	DEBUG	%s: recvd invalid skb	ERROR
NOL	DEBUG	unable to register KIFDEV to UMI	ERROR
WARNING!!! 10 minute CAC period as channel is a weather radar channel	DEBUG	The system is going to factory defaults.....!!!	CRITICAL
%s disable detects, __func__	DEBUG	%s, msg	CRITICAL
%s enable detects, __func__	DEBUG	%02x, *(data + i)	CRITICAL
%s disable FFT val=0x%x , __func__, val	DEBUG	Inside crypt_open in driver #####	CRITICAL
%s enable FFT val=0x%x , __func__, val	DEBUG	Inside crypt_release in driver #####	CRITICAL
%s debug level now = 0x%x , __func__, dfs_debug_level	DEBUG	Inside crypt_init module in driver @@@@	CRITICAL
RateTable:%d, maxvalidrate:%d, ratemax:%d, pRc->rateTableSize,k,pRc->rateMaxPhy	DEBUG	Inside crypt_cleanup module in driver @@@@	CRITICAL
%s: txRate value of 0x%x is bad., __FUNCTION__, txRate	DEBUG	SKB is null : %p ,skb	CRITICAL
Valid Rate Table:-	DEBUG	DST is null : %p ,dst	CRITICAL

Index:%d, value:%d, code:%x, rate:%d, flag:%x, i, (int)validRateIndex[i],	DEBUG	DEV is null %p %p ,dev,dst	CRITICAL
RateTable:%d, maxvalidrate:%d, ratemax:%d, pRc->rateTableSize,k,pRc->rateMaxPhy	DEBUG	Packet is Fragmented %d,pBufMgr->len	CRITICAL
Can't allocate memory for ath_vap.	DEBUG	Marked the packet proto:%d sip:%x dip:%x sport:%d dport:%d spi:%d,isr:%p:%p %p	CRITICAL
Unable to add an interface for ath_dev.	DEBUG	SAV CHECK FAILED IN DECRYPTION	CRITICAL
%s:[%02u] %-7s , tag, ix, ciphers[hk->kv_type]	DEBUG	FAST PATH Breaks on BUF CHECK	CRITICAL
%02x, hk->kv_val[i]	DEBUG	FAST PATH Breaks on DST CHECK	CRITICAL
mac %02x-%02x-%02x-%02x-%02x-%02x, mac[0], mac[1], mac[2], mac[3], mac[4], mac[5]	DEBUG	FAST PATH Breaks on MTU %d %d %d,bufMgrLen(pBufMgr),mtu,dst_mtu(pDst->path)	CRITICAL
mac 00-00-00-00-00-00	DEBUG	FAST PATH Breaks on MAX PACKET %d %d,bufMgrLen(pBufMgr),IP_MAX_PACKET	CRITICAL
%02x, hk->kv_mic[i]	DEBUG	SAV CHECK FAILED IN ENCRYPTION	CRITICAL
txmic	DEBUG	Match Found proto %d spi %d,pPktInfo->proto,pFlowEntry->pre.spi	CRITICAL
%02x, hk->kv_txmic[i]	DEBUG	PRE: proto: %u srcip:%u.%u.%u.%u sport:%u dstip: %u.%u.%u.%u dport: %u,	CRITICAL
Cannot support setting tx and rx keys individually	DEBUG	POST: proto: %u srcip:%u.%u.%u.%u sport:%u dstip: %u.%u.%u.%u dport: %u,	CRITICAL
bogus frame type 0x%x (%s),	DEBUG	Clearing the ISR %p,p	CRITICAL
ERROR: ieee80211_encap ret NULL	DEBUG	PROTO:%d %u.%u.%u.%u--->%u.%u.%u.%u,	CRITICAL
ERROR: ath_amsdu_attach not called	DEBUG	ESP-DONE: %p %p,sav,m	CRITICAL
%s: no memory for cwm attach, __func__	DEBUG	ESP-BAD: %p %p,sav,m	CRITICAL
%s: error - acw NULL. Possible attach failure, __func__	DEBUG	Bug in ip_route_input_slow().	CRITICAL
%s: unable to abort tx dma, __func__	DEBUG	Bug in ip_route_input_slow().	CRITICAL
%s: no memory for ff attach, __func__	DEBUG	Bug in ip_route_input \	CRITICAL
Failed to initiate PBC based enrolle association	DEBUG	Bug in ip_route_input_slow().	CRITICAL
KERN_EMERG Returing error in INTR registration	DEBUG	AH: Assigning the secure flags for sav :%p,sav	CRITICAL
KERN_EMERG Initialzing Wps module	DEBUG	ESP: Assigning the secure flags for sav :%p skb:%p src:%x dst:%x,sav,skb,ip->ip_src.s_addr,ip->ip_dst.s_addr	CRITICAL
%s:%d %s, __FILE__, __LINE__, __func__	DEBUG	%s Buffer %d mtu %d path mtu %d header %d trailer %d,__func__,bufMgrLen(pBufMgr),mtu ,dst_mtu(pDst->path),pDst->header_len,pDst->trailer_len	CRITICAL



## Appendix E. RJ-45 Pin-outs

Signal	RJ-45 Cable RJ-45 PIN	Adapter DB-9 PIN	Signal
CTS	NC	NC	NC
DTR	NC	NC	NC
TxD	6	3	RxD
GND	5	5	GND
GND	4	5	GND
RxD	3	2	TxD
DSR	NC	NC	NC
RTS	NC	NC	NC

# Appendix F. Product Statement

## 1. DSR-1000N

### **Federal Communications Commission (FCC) Compliance Notice: Radio Frequency Notice**

This equipment has been tested and found to comply with the limits for a Class B digital device, pursuant to part 15 of the FCC Rules. These limits are designed to provide reasonable protection against harmful interference in a residential installation. This equipment generates, uses, and can radiate radio frequency energy and, if not installed and used in accordance with the instructions, may cause harmful interference to radio communications. However, there is no guarantee that interference will not occur in a particular installation. If this equipment does cause harmful interference to radio or television reception, which can be determined by turning the equipment off and on, the user is encouraged to try to correct the interference by one or more of the following measures:

- Reorient or relocate the receiving antenna.
- Increase the separation between the equipment and receiver.
- Connect the equipment into an outlet on a circuit different from that to which the receiver is connected.
- Consult the dealer or an experienced radio/TV technician for help.

### **FCC Radiation Exposure Statement**

This equipment complies with FCC RF radiation exposure limits set forth for an uncontrolled environment. This equipment should be installed and operated with a minimum distance of 20 centimeters between the radiator and your body.

This device complies with Part 15 of the FCC Rules. Operation is subject to the following two conditions:

- 1) This device may not cause harmful interference, and
- 2) This device must accept any interference received, including interference that may cause undesired operation.

This transmitter must not be co-located or operating in conjunction with any other antenna or transmitter.

The antennas used for this transmitter must be installed to provide a spectrum distance of at least 20cm from all persons and must not be co-located or operating in conjunction with any other antenna or transmitter.

This transmitter is restricted to indoor use in the 5150MHz to 5250MHz frequency range.

### **Non-modification Statement**

Use only the integral antenna supplied by the manufacturer when operating this device. Unauthorized antennas, modifications, or attachments could damage the TI Navigator access point and violate FCC regulations. Any changes or modifications not expressly approved by the party responsible for compliance could void the user's authority to operate this equipment.

### **Canadian Department of Communications Industry Canada (IC) Notice**

This Class B digital apparatus complies with Canadian ICES-003 and RSS-210. Cet appareil numérique de la classe B est conforme à la norme NMB-003 et CNR-210 du Canada.

### **Industry Canada Statement**

This device complies with RSS-210 of the Industry Canada Rules. Operation is subject to the following two conditions:

- 1) This device may not cause harmful interference, and
- 2) This device must accept any interference received, including interference that may cause undesired operation.

**IMPORTANT NOTE: Radiation Exposure Statement**

This equipment complies with IC radiation exposure limits set forth for an uncontrolled environment. End users must follow the specific operating instructions for satisfying RF exposure compliance. To maintain compliance with IC RF exposure compliance requirements, please follow operation instruction as documented in this manual.

This transmitter is restricted to indoor use in the 5150MHz to 5250MHz frequency range.

**Europe – EU Declaration of Conformity**

This device complies with the essential requirements of the R&TTE Directive 1999/5/EC. The following test methods have been applied in order to prove presumption of conformity with the essential requirements of the R&TTE Directive 1999/5/EC:

- EN 60950-1: 2006+A11:2009

Safety of information technology equipment

- EN 300 328 V1.7.1 (2006-10)

Electromagnetic compatibility and Radio spectrum Matters (ERM); Wideband transmission systems; Data transmission equipment operating in the 2,4 GHz ISM band and using wide band modulation techniques; Harmonized EN covering essential requirements under article 3.2 of the R&TTE Directive

- EN 301 893-1 V1.5.1 (2008-12)

Broadband Radio Access Networks (BRAN); 5 GHz high performance RLAN; Harmonized EN covering essential requirements of article 3.2 of the R&TTE Directive

- EN 301 489-17 V1.3.2 (2008-04) and EN 301 489-1 V1.8.1 (2008-04)

Electromagnetic compatibility and Radio spectrum Matters (ERM); Electro Magnetic Compatibility (EMC) standard for radio equipment and services; Part 17: Specific conditions for 2,4 GHz wideband transmission systems and 5 GHz high performance RLAN equipment

This device is a 2.4 GHz wideband transmission system (transceiver), intended for use in all EU member states and EFTA countries under the following conditions and/or with the following restrictions:

- In Italy the end-user should apply for a license at the national spectrum authorities in order to obtain authorization to use the device for setting up outdoor radio links and/or for supplying public access to telecommunications and/or network services.

- This device may not be used for setting up outdoor radio links in France and in some areas the RF output power may be limited to 10 mW EIRP in the frequency range of 2454 – 2483.5 MHz. For detailed information the enduser should contact the national spectrum authority in France.



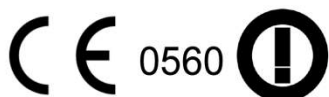

This device is a 5 GHz wideband transmission system (transceiver), intended for use in all EU member states and EFTA countries under the following conditions and/or with the following restrictions:

- This device may only be used indoors in the frequency bands 5150 – 5250 MHz.

- In France and Luxembourg a limited implementation of the frequency bands 5150 – 5250 MHz and 5250 – 5350 MHz. In Luxembourg it is not allowed to make use of the frequency band 5470 – 5725 MHz. End-users are encouraged to contact the national spectrum authorities in France and Luxembourg in order to obtain the latest information about any restrictions in the 5 GHz frequency band(s).



 Český [Czech]	[D-Link Corporation] tímto prohlašuje, že tento [DSR-1000N] je ve shodě se základními požadavky a dalšími příslušnými ustanoveními směrnice 1999/5/ES.
 Dansk [Danish]	Undertegnede [D-Link Corporation] erklærer herved, at følgende udstyr [DSR-1000N] overholder de væsentlige krav og øvrige relevante krav i direktiv 1999/5/EF.
 Deutsch [German]	Hiermit erkläre [D-Link Corporation], dass sich das Gerät [DSR-1000N] in Übereinstimmung mit den grundlegenden Anforderungen und den übrigen einschlägigen Bestimmungen der Richtlinie 1999/5/EG befindet.
 Eesti [Estonian]	Käesolevaga kinnitab [D-Link Corporation] seadme [DSR-1000N] vastavust direktiivi 1999/5/EÜ põhinõuetele ja nimetatud direktiivist tulenevatele teistele asjakohastele sätetele.
 English	Hereby, [D-Link Corporation], declares that this [DSR-1000N] is in compliance with the essential requirements and other relevant provisions of Directive 1999/5/EC.
 Español [Spanish]	Por medio de la presente [D-Link Corporation] declara que el [DSR-1000N] cumple con los requisitos esenciales y cualesquiera otras disposiciones aplicables o exigibles de la Directiva 1999/5/CE.
 Ελληνική [Greek]	ΜΕ ΤΗΝ ΠΑΡΟΥΣΑ [D-Link Corporation] ΔΗΛΩΝΕΙ ΟΤΙ [DSR-1000N] ΣΥΜΜΟΡΦΩΝΕΤΑΙ ΠΡΟΣ ΤΙΣ ΟΥΣΙΩΔΕΙΣ ΑΠΑΙΤΗΣΕΙΣ ΚΑΙ ΤΙΣ ΛΟΙΠΕΣ ΣΧΕΤΙΚΕΣ ΔΙΑΤΑΞΕΙΣ ΤΗΣ ΟΔΗΓΙΑΣ 1999/5/ΕΚ.
 Français [French]	Par la présente [D-Link Corporation] déclare que l'appareil [DSR-1000N] est conforme aux exigences essentielles et aux autres dispositions pertinentes de la directive 1999/5/CE.
 Italiano [Italian]	Con la presente [D-Link Corporation] dichiara che questo [DSR-1000N] è conforme ai requisiti essenziali ed alle altre disposizioni pertinenti stabilite dalla direttiva 1999/5/CE.
 Latviski [Latvian]	Ar šo [D-Link Corporation] deklarē, ka [DSR-1000N] atbilst Direktīvas 1999/5/EK būtiskajām prasībām un citiem ar to saistītajiem noteikumiem.
 Lietuvių [Lithuanian]	Šiuo [D-Link Corporation] deklaruoja, kad šis [DSR-1000N] atitinka esminius reikalavimus ir kitas 1999/5/EB Direktyvos nuostatas.
 Nederlands [Dutch]	Hierbij verklaart [D-Link Corporation] dat het toestel [DSR-1000N] in overeenstemming is met de essentiële eisen en de andere relevante bepalingen van richtlijn 1999/5/EG.
 Malti [Maltese]	Hawnhekk, [D-Link Corporation], jiddikjara li dan [DSR-1000N] jikkonforma mal-ħtiġijiet essenzjali u ma prowedimenti oħrajn rilevanti li hemm fid-Dirrettiva 1999/5/EC.
 Magyar [Hungarian]	Alulírott, [D-Link Corporation] nyilatkozom, hogy a [DSR-1000N] megfelel a vonatkozó alapvető követelményeknek és az 1999/5/EC irányelv egyéb előírásainak.
 Polski [Polish]	Niniejszym [D-Link Corporation] oświadcza, że [DSR-1000N] jest zgodny z zasadniczymi wymogami oraz pozostałymi stosownymi postanowieniami Dyrektywy 1999/5/EC.

 Portuguese [Portuguese]	[D-Link Corporation] declara que este [DSR-1000N] está conforme com os requisitos essenciais e outras disposições da Directiva 1999/5/CE.
 Slovensko [Slovenian]	[D-Link Corporation] izjavlja, da je ta [DSR-1000N] v skladu z bistvenimi zahtevami in ostalimi relevantnimi določili direktive 1999/5/ES.
 Slovensky [Slovak]	[D-Link Corporation] týmto vyhlasuje, že [DSR-1000N] spĺňa základné požiadavky a všetky príslušné ustanovenia Smernice 1999/5/ES.
 Suomi [Finnish]	[D-Link Corporation] vakuuttaa täten että [DSR-1000N] tyypinen laite on direktiivin 1999/5/EY oleellisten vaatimusten ja sitä koskevien direktiivin muiden ehtojen mukainen.
 Svenska [Swedish]	Härmed intygar [D-Link Corporation] att denna [DSR-1000N] står i överensstämmelse med de väsentliga egenskapskrav och övriga relevanta bestämmelser som framgår av direktiv 1999/5/EG.

## **2.DSR-500N**

### **Federal Communications Commission (FCC) Compliance Notice: Radio Frequency Notice**

This equipment has been tested and found to comply with the limits for a Class B digital device, pursuant to part 15 of the FCC Rules. These limits are designed to provide reasonable protection against harmful interference in a residential installation. This equipment generates, uses, and can radiate radio frequency energy and, if not installed and used in accordance with the instructions, may cause harmful interference to radio communications. However, there is no guarantee that interference will not occur in a particular installation. If this equipment does cause harmful interference to radio or television reception, which can be determined by turning the equipment off and on, the user is encouraged to try to correct the interference by one or more of the following measures:

- Reorient or relocate the receiving antenna.
- Increase the separation between the equipment and receiver.
- Connect the equipment into an outlet on a circuit different from that to which the receiver is connected.
- Consult the dealer or an experienced radio/TV technician for help.

### **FCC Radiation Exposure Statement**

This equipment complies with FCC RF radiation exposure limits set forth for an uncontrolled environment. This equipment should be installed and operated with a minimum distance of 20 centimeters between the radiator and your body.

This device complies with Part 15 of the FCC Rules. Operation is subject to the following two conditions:

- 1) This device may not cause harmful interference, and
- 2) This device must accept any interference received, including interference that may cause undesired operation.

This transmitter must not be co-located or operating in conjunction with any other antenna or transmitter.

The antennas used for this transmitter must be installed to provide a spectrum distance of at least 20cm from all persons and must not be co-located or operating in conjunction with any other antenna or transmitter.

This transmitter is restricted to indoor use in the 5150MHz to 5250MHz frequency range.

### **Non-modification Statement**

Use only the integral antenna supplied by the manufacturer when operating this device. Unauthorized antennas, modifications, or attachments could damage the TI Navigator access point and violate FCC regulations. Any changes or modifications not expressly approved by the party responsible for compliance could void the user's authority to operate this equipment.

### **Canadian Department of Communications Industry Canada (IC) Notice**

This Class B digital apparatus complies with Canadian ICES-003 and RSS-210. Cet appareil numérique de la classe B est conforme à la norme NMB-003 et CNR-210 du Canada.

### **Industry Canada Statement**

This device complies with RSS-210 of the Industry Canada Rules. Operation is subject to the following two conditions:

- 1) This device may not cause harmful interference, and
- 2) This device must accept any interference received, including interference that may cause undesired operation.

### **IMPORTANT NOTE: Radiation Exposure Statement**

This equipment complies with IC radiation exposure limits set forth for an uncontrolled environment. End users must follow the specific operating instructions for satisfying RF exposure compliance. To maintain compliance with IC RF exposure compliance requirements, please follow operation instruction as documented in this manual.

**Europe – EU Declaration of Conformity**









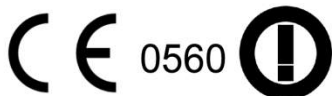



This device complies with the essential requirements of the R&TTE Directive 1999/5/EC. The following test methods have been applied in order to prove presumption of conformity with the essential requirements of the R&TTE Directive 1999/5/EC:

- EN 60950-1:2006+A11:2009  
Safety of information technology equipment
- EN 300 328 V1.7.1 (2006-10)  
Electromagnetic compatibility and Radio spectrum Matters (ERM); Wideband transmission systems; Data transmission equipment operating in the 2,4 GHz ISM band and using wide band modulation techniques; Harmonized EN covering essential requirements under article 3.2 of the R&TTE Directive
- EN 301 489-17 V1.3.2 (2008-04) and EN 301 489-1 V1.8.1 (2008-04)  
Electromagnetic compatibility and Radio spectrum Matters (ERM); Electro Magnetic Compatibility (EMC) standard for radio equipment and services; Part 17: Specific conditions for 2,4 GHz wideband transmission systems and 5 GHz high performance RLAN equipment





This device is a 2.4 GHz wideband transmission system (transceiver), intended for use in all EU member states and EFTA countries under the following conditions and/or with the following restrictions:

- In Italy the end-user should apply for a license at the national spectrum authorities in order to obtain authorization to use the device for setting up outdoor radio links and/or for supplying public access to telecommunications and/or network services.
- This device may not be used for setting up outdoor radio links in France and in some areas the RF output power may be limited to 10 mWEIRP in the frequency range of 2454 – 2483.5 MHz. For detailed information the enduser should contact the national spectrum authority in France.



 Český [Czech]	[D-Link Corporation] tímto prohlašuje, že tento [DSR-500N] je ve shodě se základními požadavky a dalšími příslušnými ustanoveními směrnice 1999/5/ES.
 Dansk [Danish]	Undertegnede [D-Link Corporation] erklærer herved, at følgende udstyr [DSR-500N] overholder de væsentlige krav og øvrige relevante krav i direktiv 1999/5/EF.
 Deutsch [German]	Hiermit erkläre [D-Link Corporation], dass sich das Gerät [DSR-500N] in Übereinstimmung mit den grundlegenden Anforderungen und den übrigen einschlägigen Bestimmungen der Richtlinie 1999/5/EG befindet.
 Eesti [Estonian]	Käesolevaga kinnitab [D-Link Corporation] seadme [DSR-500N] vastavust direktiivi 1999/5/EÜ põhinõuetele ja nimetatud direktiivist tulenevatele teistele asjakohastele sätetele.
 English	Hereby, [D-Link Corporation], declares that this [DSR-500N] is in compliance with the essential requirements and other relevant provisions of Directive 1999/5/EC.
 Español [Spanish]	Por medio de la presente [D-Link Corporation] declara que el [DSR-500N] cumple con los requisitos esenciales y cualesquiera otras disposiciones aplicables o exigibles de la Directiva 1999/5/CE.
 Ελληνική [Greek]	ΜΕ ΤΗΝ ΠΑΡΟΥΣΑ [D-Link Corporation] ΔΗΛΩΝΕΙ ΟΤΙ [DSR-500N] ΣΥΜΜΟΡΦΩΝΕΤΑΙ ΠΡΟΣ ΤΙΣ ΟΥΣΙΩΔΕΙΣ ΑΠΑΙΤΗΣΕΙΣ ΚΑΙ ΤΙΣ ΛΟΙΠΕΣ ΣΧΕΤΙΚΕΣ ΔΙΑΤΑΞΕΙΣ ΤΗΣ ΟΔΗΓΙΑΣ 1999/5/ΕΚ.
 Français [French]	Par la présente [D-Link Corporation] déclare que l'appareil [DSR-500N] est conforme aux exigences essentielles et aux autres dispositions pertinentes de la directive 1999/5/CE.
 Italiano [Italian]	Con la presente [D-Link Corporation] dichiara che questo [DSR-500N] è conforme ai requisiti essenziali ed alle altre disposizioni pertinenti stabilite dalla direttiva 1999/5/CE.
 Latviski [Latvian]	Ar šo [D-Link Corporation] deklarē, ka [DSR-500N] atbilst Direktīvas 1999/5/EK būtiskajām prasībām un citiem ar to saistītajiem noteikumiem.
 Lietuvių [Lithuanian]	Šiuo [D-Link Corporation] deklaruojama, kad šis [DSR-500N] atitinka esminius reikalavimus ir kitas 1999/5/EB Direktyvos nuostatas.
 Nederlands [Dutch]	Hierbij verklaart [D-Link Corporation] dat het toestel [DSR-500N] in overeenstemming is met de essentiële eisen en de andere relevante bepalingen van richtlijn 1999/5/EG.
 Malti [Maltese]	Hawnhekk, [D-Link Corporation], jiddikjara li dan [DSR-500N] jikkonforma mal-ħtiġijiet essenzjali u ma پروvedimenti oħrajn relevanti li hemm fid-Dirrettiva 1999/5/EC.
 Magyar [Hungarian]	Alulírott, [D-Link Corporation] nyilatkozom, hogy a [DSR-500N] megfelel a vonatkozó alapvető követelményeknek és az 1999/5/EC irányelv egyéb előírásainak.
 Polski [Polish]	Niniejszym [D-Link Corporation] oświadczam, że [DSR-500N] jest zgodny z zasadniczymi wymogami oraz pozostałymi stosownymi postanowieniami Dyrektywy 1999/5/EC.



 Portuguese [Portuguese]	[D-Link Corporation] declara que este [DSR-500N] está conforme com os requisitos essenciais e outras disposições da Directiva 1999/5/CE.
 Slovensko [Slovenian]	[D-Link Corporation] izjavlja, da je ta [DSR-500N] v skladu z bistvenimi zahtevami in ostalimi relevantnimi določili direktive 1999/5/ES.
 Slovensky [Slovak]	[D-Link Corporation] týmto vyhlasuje, že [DSR-500N] spĺňa základné požiadavky a všetky príslušné ustanovenia Smernice 1999/5/ES.
 Suomi [Finnish]	[D-Link Corporation] vakuuttaa täten että [DSR-500N] tyypinen laite on direktiivin 1999/5/EY oleellisten vaatimusten ja sitä koskevien direktiivin muiden ehtojen mukainen.
 Svenska [Swedish]	Härmed intygar [D-Link Corporation] att denna [DSR-500N] står i överensstämmelse med de väsentliga egenskapskrav och övriga relevanta bestämmelser som framgår av direktiv 1999/5/EG.

### **3.DSR-250N**

#### **Federal Communication Commission Interference Statement**

This equipment has been tested and found to comply with the limits for a Class B digital device, pursuant to Part 15 of the FCC Rules. These limits are designed to provide reasonable protection against harmful interference in a residential installation. This equipment generates, uses and can radiate radio frequency energy and, if not installed and used in accordance with the instructions, may cause harmful interference to radio communications. However, there is no guarantee that interference will not occur in a particular installation. If this equipment does cause harmful interference to radio or television reception, which can be determined by turning the equipment off and on, the user is encouraged to try to correct the interference by one of the following measures:

- Reorient or relocate the receiving antenna.
- Increase the separation between the equipment and receiver.
- Connect the equipment into an outlet on a circuit different from that to which the receiver is connected.
- Consult the dealer or an experienced radio/TV technician for help.

#### **FCC Caution:**

Any changes or modifications not expressly approved by the party responsible for compliance could void the user's authority to operate this equipment.

This device complies with Part 15 of the FCC Rules. Operation is subject to the following two conditions: (1) This device may not cause harmful interference, and (2) this device must accept any interference received, including interference that may cause undesired operation.

#### **RSS-GEN 7.1.4:**

User Manual for Transmitters with Detachable Antennas

The user manual of transmitter devices equipped with detachable antennas shall contain the following information in a conspicuous location:

This device has been designed to operate with the antennas listed below, and having a maximum gain of [1.8] dB. Antennas not included in this list or having a gain greater than [1.8] dB are strictly prohibited for use with this device. The required antenna impedance is [50] ohms.

#### **RSS-GEN 7.1.5**

To reduce potential radio interference to other users, the antenna type and its gain should be so chosen that the equivalent isotropically radiated power (e.i.r.p.) is not more than that permitted for successful communication.

Le présent appareil est conforme aux CNR d'Industrie Canada applicables aux appareils radio exempts de licence. L'exploitation est autorisée aux deux conditions suivantes: (1) l'appareil ne doit pas produire de brouillage, et (2) l'utilisateur de l'appareil doit accepter tout brouillage radioélectrique subi, même si le brouillage est susceptible d'en compromettre le fonctionnement.



Is herewith confirmed to comply with the requirements set out in the Council Directive on the Approximation of the Laws of the Member States relating to Electromagnetic Compatibility (2004/108/EC), Low-voltage Directive (2006/95/EC), the procedures given in European Council Directive 99/5/EC and 2004/104/EC.

The equipment was passed. The test was performed according to the following European standards:

EN 300 328 V.1.7.1

EN 301 489-1 V.1. 8.1 / EN 301 489-17 V.2.1.1

EN 62311

EN 60950-1

**Regulatory statement (R&TTE)**

European standards dictate maximum radiated transmit power of 100mW EIRP and frequency range 2.400-2.4835GHz; In France, the equipment must be restricted to the 2.4465-2.4835GHz frequency range and must be restricted to indoor use.

Operation of this device is subjected to the following National regulations and may be prohibited to use if certain restriction should be applied.

$D=0.020m$  is the minimum safety distance between the EUT and human body when the E-Field strength is 61V/m.

**NCC Warning Statement****Article 12**

Without permission, any company, firm or user shall not alter the frequency, increase the power, or change the characteristics and functions of the original design of the certified lower power frequency electric machinery.

**Article 14**

The application of low power frequency electric machineries shall not affect the navigation safety nor interfere a legal communication, if an interference is found, the service will be suspended until improvement is made and the interference no longer exists.

## **4. DSR-150N**

### **Federal Communication Commission Interference Statement**

This equipment has been tested and found to comply with the limits for a Class B digital device, pursuant to Part 15 of the FCC Rules. These limits are designed to provide reasonable protection against harmful interference in a residential installation. This equipment generates, uses and can radiate radio frequency energy and, if not installed and used in accordance with the instructions, may cause harmful interference to radio communications. However, there is no guarantee that interference will not occur in a particular installation. If this equipment does cause harmful interference to radio or television reception, which can be determined by turning the equipment off and on, the user is encouraged to try to correct the interference by one of the following measures:

- Reorient or relocate the receiving antenna.
- Increase the separation between the equipment and receiver.
- Connect the equipment into an outlet on a circuit different from that to which the receiver is connected.
- Consult the dealer or an experienced radio/TV technician for help.

### **FCC Caution:**

Any changes or modifications not expressly approved by the party responsible for compliance could void the user's authority to operate this equipment. This device complies with Part 15 of the FCC Rules. Operation is subject to the following two conditions:

- (1) This device may not cause harmful interference, and
- (2) this device must accept any interference received, including interference that may cause undesired operation.

### **IMPORTANT NOTE:**

#### **FCC Radiation Exposure Statement:**

This equipment complies with FCC radiation exposure limits set forth for an uncontrolled environment. This equipment should be installed and operated with minimum distance 20cm between the radiator & your body. This transmitter must not be co-located or operating in conjunction with any other antenna or transmitter. The availability of some specific channels and/or operational frequency bands are country dependent and are firmware programmed at the factory to match the intended destination. The firmware setting is not accessible by the end user.

**Note:** The country code selection is for non-US model only and is not available to all US model. Per FCC regulation, all WiFi product marketed in US must fixed to US operation channels only..

#### **Europe – EU Declaration of Conformity**

This device complies with the essential requirements of the R&TTE Directive 1999/5/EC. The following test methods have been applied in order to prove presumption of conformity with the essential requirements of the R&TTE Directive 1999/5/EC:

#### **EN 60950-1:**

Safety of Information Technology Equipment

#### **EN50385 : (2002-08)**

Product standard to demonstrate the compliance of radio base stations and fixed terminal stations for wireless telecommunication systems with the basic restrictions or the reference levels related to human exposure to radio frequency electromagnetic fields (110MHz - 40 GHz) - General public

#### **EN 300 328 V1.7.1: (2006-10)**

Electromagnetic compatibility and Radio spectrum Matters (ERM); Wideband Transmission systems; Data transmission equipment operating in the 2,4 GHz ISM band and using spread spectrum modulation techniques; Harmonized EN covering essential requirements under article 3.2 of the R&TTE Directive

#### **EN 301 489-1 V1.8.1: (2008-04)**

Electromagnetic compatibility and Radio Spectrum Matters (ERM); ElectroMagnetic Compatibility (EMC) standard for radio equipment and services; Part 1: Common technical requirements

**EN 301 489-17 V2.1.1 (2009-05)**

Electromagnetic compatibility and Radio spectrum Matters (ERM); ElectroMagnetic Compatibility (EMC) standard for radio equipment; Part 17: Specific conditions for Broadband Data Transmission Systems

This device is a 2.4 GHz wideband transmission system (transceiver), intended for use in all EU member states and EFTA countries, except in France and Italy where restrictive use applies.

In Italy the end-user should apply for a license at the national spectrum authorities in order to obtain authorization to use the device for setting up outdoor radio links and/or for supplying public access to telecommunications and/or network services.

This device may not be used for setting up outdoor radio links in France and in some areas the RF output power may be limited to 10 mW EIRP in the frequency range of 2454 – 2483.5 MHz. For detailed information the end-user should contact the national spectrum authority in France.



[cs] Český [Czech]	[Jméno výrobce] tímto prohlašuje, že tento [typ zařízení] je ve shodě se základními požadavky a dalšími příslušnými ustanoveními směrnice 1999/5/ES.
[da] Dansk [Danish]	Undertegnede [fabrikantens navn] erklærer herved, at følgende udstyr [udstyrets typebetegnelse] overholder de væsentlige krav og øvrige relevante krav i direktiv 1999/5/EF.
[de] Deutsch [German]	Hiermit erkläre [Name des Herstellers], dass sich das Gerät [Gerätetyp] in Übereinstimmung mit den grundlegenden Anforderungen und den übrigen einschlägigen Bestimmungen der Richtlinie 1999/5/EG befindet.
[et] Eesti [Estonian]	Käesolevaga kinnitab [tootja nimi = name of manufacturer] seadme [seadme tüüp = type of equipment] vastavust direktiivi 1999/5/EÜ põhinõuetele ja nimetatud direktiivist tulenevatele teistele asjakohastele sätetele.
[en] English	Hereby, [name of manufacturer], declares that this [type of equipment] is in compliance with the essential requirements and other relevant provisions of Directive 1999/5/EC.
[es] Español [Spanish]	Por medio de la presente [nombre del fabricante] declara que el [clase de equipo] cumple con los requisitos esenciales y cualesquiera otras disposiciones aplicables o exigibles de la Directiva 1999/5/CE.
[el] Ελληνική [Greek]	ΜΕ ΤΗΝ ΠΑΡΟΥΣΑ [name of manufacturer] ΔΗΛΩΝΕΙ ΟΤΙ [type of equipment] ΣΥΜΜΟΡΦΩΝΕΤΑΙ ΠΡΟΣ ΤΙΣ ΟΥΣΙΩΔΕΙΣ ΑΠΑΙΤΗΣΕΙΣ ΚΑΙ ΤΙΣ ΛΟΙΠΕΣ ΣΧΕΤΙΚΕΣ ΔΙΑΤΑΞΕΙΣ ΤΗΣ ΟΔΗΓΙΑΣ 1999/5/EK.
[fr] Français [French]	Par la présente [nom du fabricant] déclare que l'appareil [type d'appareil] est conforme aux exigences essentielles et aux autres dispositions pertinentes de la directive 1999/5/CE.
[it] Italiano [Italian]	Con la presente [nome del costruttore] dichiara che questo [tipo di apparecchio] è conforme ai requisiti essenziali ed alle altre disposizioni pertinenti stabilite dalla direttiva 1999/5/CE.
Latviski [Latvian]	Ar šo [name of manufacturer / izgatavotāja nosaukums] deklarē, ka [type of equipment / iekārtas tips] atbilst Direktīvas 1999/5/EK būtiskajām prasībām un citiem ar to saistītajiem noteikumiem.
Lietuvių [Lithuanian]	Šiuo [manufacturer name] deklaruoją, kad šis [equipment type] atitinka esminius reikalavimus ir kitas 1999/5/EB Direktyvos nuostatas.
[nl] Nederlands [Dutch]	Hierbij verklaart [naam van de fabrikant] dat het toestel [type van toestel] in overeenstemming is met de essentiële eisen en de andere relevante bepalingen van richtlijn 1999/5/EG.
[mt] Malti [Maltese]	Hawnhekk, [isem tal-manifattur], jiddikjara li dan [il-mudel tal-prodott] jikkonforma mal-ħtiġijiet essenzjali u ma provvedimenti oħrajn relevanti li hemm fid-Dirrettiva 1999/5/EC.
[hu] Magyar	Alulírott, [gyártó neve] nyilatkozom, hogy a [...] típus] megfelel a vonatkozó alapvető

[Hungarian]	követelményeknek és az 1999/5/EC irányelv egyéb előírásainak.
[pl] Polski [Polish]	Niniejszym [nazwa producenta] oświadcza, że [nazwa wyrobu] jest zgodny z zasadniczymi wymogami oraz pozostałymi stosownymi postanowieniami Dyrektywy 1999/5/EC.
[pt] Português [Portuguese]	[Nome do fabricante] declara que este [tipo de equipamento] está conforme com os requisitos essenciais e outras disposições da Directiva 1999/5/CE.
[sl] Slovensko [Slovenian]	[Ime proizvajalca] izjavlja, da je ta [tip opreme] v skladu z bistvenimi zahtevami in ostalimi relevantnimi določili direktive 1999/5/ES.
Slovensky [Slovak]	[Meno výrobcu] týmto vyhlasuje, že [typ zariadenia] spĺňa základné požiadavky a všetky príslušné ustanovenia Smernice 1999/5/ES.
[fi] Suomi [Finnish]	[Valmistaja = manufacturer] vakuuttaa täten että [type of equipment = laiteen tyypimerkintä] tyypinen laite on direktiivin 1999/5/EY oleellisten vaatimusten ja sitä koskevien direktiivin muiden ehtojen mukainen.
[sv] Svenska [Swedish]	Härmed intygar [företag] att denna [utrustningstyp] står i överensstämmelse med de väsentliga egenskapskrav och övriga relevanta bestämmelser som framgår av direktiv 1999/5/EG.

**Industry Canada statement:**

This device complies with RSS-210 of the Industry Canada Rules. Operation is subject to the following two conditions:

- (1) This device may not cause harmful interference, and
- (2) This device must accept any interference received, including interference that may cause undesired operation.

Ce dispositif est conforme à la norme CNR-210 d'Industrie Canada applicable aux appareils radio exempts de licence. Son fonctionnement est sujet aux deux conditions suivantes: (1) le dispositif ne doit pas produire de brouillage préjudiciable, et (2) ce dispositif doit accepter tout brouillage reçu, y compris un brouillage susceptible de provoquer un fonctionnement indésirable.

**Radiation Exposure Statement:**

This equipment complies with IC radiation exposure limits set forth for an uncontrolled environment. This equipment should be installed and operated with minimum distance 20cm between the radiator & your body.

**Déclaration d'exposition aux radiations:**

Cet équipement est conforme aux limites d'exposition aux rayonnements IC établies pour un environnement non contrôlé. Cet équipement doit être installé et utilisé avec un minimum de 20 cm de distance entre la source de rayonnement et votre corps.

**Wall-Mount Option**

The Router has four wall-mount slots on its bottom panel.

Before you begin, make sure you have two screws that are size #4 - this indicates a diameter measurement of 0.112 inches (2.845mm).

1. Determine where you want to mount the Router.
2. Drill two holes into the wall. Make sure adjacent holes are 2.36 inches (60mm) apart.
3. Insert a screw into each hole, and leave 0.2 inches (5mm) of its head exposed.
4. Maneuver the Router so the wall-mount slots line up with the two screws.
5. Place the wall-mount slots over the screws and slide the Router down until the screws fit snugly into the wall-mount slots.